

# Regulation 2023

## Program Structure



### 1021 Diploma in Automobile Engineering

#### Program Outcomes (PO's)

POs are statements that describe what students are expected to know and be able to do upon graduating from the program. These relate to the skills, knowledge, analytical ability, attitude, and behavior that students acquire through the program.

The POs essentially indicate what the students can do from subject-wise knowledge acquired by them during the program. As such, POs define the professional profile of an engineering diploma graduate.

NBA has defined the following seven POs for an Engineering diploma graduate:

**PO1:** Basic and Discipline-specific knowledge: Apply knowledge of basic mathematics, science and engineering fundamentals and an engineering specialization to solve the engineering problems.

**PO2:** Problem analysis: Identify and analyse well-defined engineering problems using codified standard methods.

**PO3:** Design/ development of solutions: Design solutions for well-defined technical problems and assist with the design of systems components or processes to meet specified needs.

**PO4:** Engineering Tools, Experimentation, and Testing: Apply modern engineering tools and appropriate technique to conduct standard tests and measurements.

**PO5:** Engineering practices for society, sustainability and environment: Apply appropriate technology in the context of society, sustainability, environment and ethical practices.

**PO6:** Project Management: Use engineering management principles individually, as a team member or as a leader to manage projects and effectively communicate about well-defined engineering activities.

**PO7:** Life-long learning: Ability to analyse individual needs and engage in updating in the context of technological changes.

### Credit Distribution

<b>Semester</b>	<b>No of Courses</b>	<b>Periods</b>	<b>Credits</b>
Semester I	8	640	20
Semester II	9	640	20
Semester III	7	640	21
Semester IV	7	640	19
Semester V	8	640	22
Semester VI	3	660	18
<b>Total</b>			<b>120</b>

# Industrial Training during Summer vacation for Two Weeks has to be completed to earn the required two credits.

**GOVERNMENT OF TAMIL NADU**  
**DEPARTMENT OF TECHNICAL EDUCATION**  
**DIPLOMA IN ENGINEERING & TECHNOLOGY - REGULATION 2023**  
**1021 DIPLOMA IN AUTOMOBILE ENGINEERING (FT)**

<b>Semester III</b>								
#	Course Category	Course Type	Code	Course Title	L-T-P	Period	Credit	End Exam
1	Program Core	Theory	1021233110	Manufacturing Technology I	3-0-0	45	3	Theory
2	Program Core	Practicum	1021233230	Automotive Engines	2-0-2	60	3	Theory
3	Program Core	Practicum	1021233340	Mechanics of Materials	1-0-4	75	3	Practical
4	Program Core	Practicum	1021233440	Automotive Electrical and Electronics Systems	1-0-4	75	3	Practical
5	Program Core	Practicum	1021233540	Automobile Engineering Drawing	1-0-4	75	3	Practical
6	Program Core	Practicum	1021233640	Fluid Power Systems	1-0-4	75	3	Practical
7	Open Elective	Advanced Skill Certification	1021233760	Advanced Skills Certification - III	1-0-2	60	2	NA
8	Humanities & Social Science	Integrated Learning Experience	1021233880	Growth Lab	-	30	-	-
9	Audit Course	Integrated Learning Experience	1021233881	Induction Program - II	-	16	-	-
10	Audit Course	Integrated Learning Experience	1021233882	I&E/ Club Activity/ Community Initiatives	-	16	-	-
11	Audit Course	Integrated Learning Experience	1021233883	Shop floor Immersion	-	8	-	-
12	Audit Course	Integrated Learning Experience	1021233884	Student-Led Initiative	-	22	-	-
13	Audit Course	Integrated Learning Experience	1021233885	Emerging Technology Seminars	-	8	-	-
14	Audit Course	Integrated Learning Experience	1021233886	Health & Wellness	-	30	1	NA
Library						15		
Test & Revisions						30		
<b>Total</b>						<b>640</b>	<b>21</b>	

**GOVERNMENT OF TAMIL NADU**  
**DEPARTMENT OF TECHNICAL EDUCATION**  
**DIPLOMA IN ENGINEERING & TECHNOLOGY - REGULATION 2023**  
**1021 DIPLOMA IN AUTOMOBILE ENGINEERING (FT)**

<b>Semester IV</b>								
<b>#</b>	<b>Course Category</b>	<b>Course Type</b>	<b>Code</b>	<b>Course Title</b>	<b>L-T-P</b>	<b>Period</b>	<b>Credit</b>	<b>End Exam</b>
1	Program Core	Theory	1021234110	Power units and Transmission	3-0-0	45	3	Theory
2	Program Core	Practicum	1021234230	Fuels, Combustion and Emission Control	2-0-2	60	3	Theory
3	Program Core	Practicum	1021234340	Manufacturing Technology II	1-0-4	75	3	Practical
4	Program Core	Practicum	1020234440	Sensors and Actuators	1-0-4	75	3	Practical
5	Program Core	Practicum	1021234540	Automobile Component Design	1-0-2	45	2	Practical
6	Program Core	Practicum	1020234640	Metrology and Measurements	1-0-4	75	3	Practical
7	Open Elective	Advanced Skill Certification	1021234760	Advanced Skills Certification - IV	1-0-2	60	2	NA
8	Audit Course	Integrated Learning Experience	1021234880	Induction Program (Driving Practice)	-	40	0	NA
9	Audit Course	Integrated Learning Experience	1021234882	I&E/ Club Activity/ Community Initiatives	-	30	0	-
10	Audit Course	Integrated Learning Experience	1021234883	Shop floor Immersion	-	15	0	-
11	Audit Course	Integrated Learning Experience	1021234884	Student-Led Initiative	-	15	0	-
12	Audit Course	Integrated Learning Experience	1021234885	Emerging Technology Seminars	-	15	0	-
13	Audit Course	Integrated Learning Experience	1021234886	Health & Wellness	-	15	0	-
14	Audit Course	Integrated Learning Experience	1021234887	Special Interest Groups (Placement Training)	-	30	0	-
						Library	15	
						Test & Revisions	30	
						<b>Total</b>	<b>640</b>	<b>19</b>

**GOVERNMENT OF TAMIL NADU**  
**DEPARTMENT OF TECHNICAL EDUCATION**  
**DIPLOMA IN ENGINEERING & TECHNOLOGY - REGULATION 2023**  
**1021 DIPLOMA IN AUTOMOBILE ENGINEERING (FT)**

<b>Semester V</b>								
#	Course Category	Course Type	Code	Course Title	L-T-P	Period	Credit	End Exam
1	Program Core	Practicum	1021235130	Vehicle Body Engineering	2-0-2	60	3	Theory
2	Program Core	Practicum	1021235230	Electric & Hybrid Vehicle technology	3-0-2	75	4	Theory
3	Program Elective	Theory		Elective - I	3-0-0	45	3	Theory
4	Program Core	Practicum	1021235440	Automobile Servicing Practical	1-0-4	75	3	Practical
5	Program Elective	Practicum		Elective - II	1-0-4	75	3	Practical
6	Humanities & Social Science	Practicum	1021235654	Innovation & Startup	1-0-2	45	2	Project
7	Project/Internship	Project/Internship	1021235773	Industrial Training* [Vacation - 90 Hours] / Mini Project (Sandwich Only)	-	-	2	Project
8	Open Elective	Advanced Skill Certification	1021235860	Advanced Skills Certification - V	1-0-2	60	2	NA
9	Audit Course	Integrated Learning Experience	1021235881	Induction program III	-	40	0	-
10	Audit Course	Integrated Learning Experience	1021235884	Student-Led Initiative	-	30	0	-
11	Audit Course	Integrated Learning Experience	1021238986	Health & Wellness	-	30	0	-
12	Audit Course	Integrated Learning Experience	1021235887	Special Interest Groups (Placement Training)	-	60	0	-
Test & Revisions						45		
<b>Total</b>						<b>640</b>	<b>22</b>	

\* All the Full Time students should undergo a minimum period of Two Weeks Industrial Training during the vacation holidays. For Sandwich Students a Mini Project has to be completed to earn the 2 credits for this course.

**GOVERNMENT OF TAMIL NADU**  
**DEPARTMENT OF TECHNICAL EDUCATION**  
**DIPLOMA IN ENGINEERING & TECHNOLOGY - REGULATION 2023**  
**1021 DIPLOMA IN AUTOMOBILE ENGINEERING (FT)**

<b>Semester VI</b>								
#	Course Category	Course Type	Code	Course Title	L-T-P	Period	Credit	End Exam
1	Program Core	Theory	1021236110	Industrial Management and Transport Engineering.	3-0-0	45	3	Theory
2	Open Elective	Practicum		Elective-III	1-0-4	75	3	Practical
3	Industrial Training / Project	Project/Internship		In-house Project / Internship / Fellowship **	-	540	12	Project
				<b>Total</b>		<b>660</b>	<b>18</b>	
3	Industrial Training / Project	Project/Internship	1021236351	Internship	-	540	12	Project
3	Industrial Training / Project	Project/Internship	1021236353	Fellowship	-	540	12	Project
3	Industrial Training / Project	Project/Internship	1021236374	In-house Project	-	540	12	Project
3	Industrial Training / Project	Project/Internship	2023234274 2023237274	Industrial Training (SW)	-	540	12	Project

Note: \*\* Every student should select any one from the In-House Project or Internship or Fellowship. The guidelines given below have to be followed.

For the Sandwich programme, Industrial Training in the fourth and seventh semester will be given. The guidelines given below have to be followed.

**GOVERNMENT OF TAMIL NADU**  
**DEPARTMENT OF TECHNICAL EDUCATION**  
**DIPLOMA IN ENGINEERING & TECHNOLOGY - REGULATION 2023**  
**1021 DIPLOMA IN AUTOMOBILE ENGINEERING (FT)**

**Elective - I**

#	Course Category	Course Type	Code	Course Title	L-T-P	Period	Credit	End Exam
1	Program Elective	Theory	1021235311	Tractor and Farm Equipment	3-0-0	45	3	Theory
2	Program Elective	Theory	1021235312	Vehicle Aerodynamics and Design	3-0-0	45	3	Theory
3	Program Elective	Theory	1021235313	Heavy Vehicle Engineering	3-0-0	45	3	Theory
4	Program Elective	Theory	1021235314	Automotive Safety Systems	3-0-0	45	3	Theory
5	Program Elective	Theory	1021235315	Advanced Automotive Systems	3-0-0	45	3	Theory
6	Program Elective	Theory	1021235316	Alternative Fuels	3-0-0	45	3	Theory
7	Program Elective	Theory	1021235317	Alternative Energy sources	3-0-0	45	3	Theory
8	Program Elective	Theory	1021235318	Special Purpose Vehicles	3-0-0	45	3	Theory

**Elective - II**

#	Course Category	Course Type	Code	Course Title	L-T-P	Period	Credit	End Exam
1	Program Elective	Practicum	1020235541	CNC Programming	1-0-4	75	3	Practical
2	Program Elective	Practicum	1021235542	Two-Wheeler and Three-Wheeler Technology	1-0-4	75	3	Practical
3	Program Elective	Practicum	1020235543	Industrial IoT	1-0-4	75	3	Practical
4	Program Elective	Practicum	1020235544	Advanced Welding Technologies	1-0-4	75	3	Practical
5	Program Elective	Practicum	1020235545	Industrial Robotics	1-0-4	75	3	Practical
6	Program Elective	Practicum	1020235546	HVAC Systems and Components	1-0-4	75	3	Practical
7	Program Elective	Practicum	1021235547	Engine Testing	1-0-4	75	3	Practical

**GOVERNMENT OF TAMIL NADU**  
**DEPARTMENT OF TECHNICAL EDUCATION**  
**DIPLOMA IN ENGINEERING & TECHNOLOGY - REGULATION 2023**  
**1021 DIPLOMA IN AUTOMOBILE ENGINEERING (FT)**

**Elective - III (Pathway)**

#	Course Category	Course Type	Code	Course Title	L-T-P	Period	Credit	End Exam
1	Elective   Technocrats	Practicum	1021236241	Vehicle Testing	1-0-4	75	3	Practical
2	Elective   Technocrats	Practicum	1021236242	Earth Moving Equipments	1-0-4	75	3	Practical
3	Elective   Technologist	Practicum	1020236243	Non-Destructive Testing	1-0-4	75	3	Practical
4	Elective   Technologist	Practicum	1020236244	Process Automation	1-0-4	75	3	Practical
5	Elective   Technologist	Practicum	1021236245	Additive Manufacturing Practical	1-0-4	75	3	Practical
6	Elective   Technocrats	Practicum	1021236246	Electrical Vehicle Technology Practical	1-0-4	75	3	Practical
7	Elective   Open elective	Practicum		Online Courses §	1-0-4	75	3	Practical

**§ Online courses with the same credit available in AICTE, SWAYAM, NPTEL and reputed Institutions with the proper evaluation system and certification can be considered after proper approval from the Chairman Board of Examinations.**

1021233110	<b>Manufacturing Technology I</b>	L	T	P	C
THEORY		3	0	0	3

**Introduction:**

Manufacturing, the major and the most important aspect in industry, needs utmost care and attention. Knowledge about casting processes and allied areas will be of great use to the personnel involved in production.

The areas like Moulding Machines, Casting Processes, Heat Treatment, Bulk Deformation Processes, Forging, Non-Conventional Machining Processes, , Manufacturing of Plastic Components, Theory of Metal Cutting and Powder Metallurgy will provide the students an opportunity to train themselves with the skills needed for the present day industrial scenario.

**Course Objectives:**

The Objective of this course is to enable the student to,

- Acquire Knowledge about types of moulding machines and casting processes heat treatment.
- Knowledge about various heat treatments and Bulk Deformation Processes.
- Acquire knowledge about forging and non-conventional machining processes
- Knowledge about the Manufacturing of Plastic Components.
- Describe the functioning of Theory of Metal Cutting and Powder Metallurgy.

**Course Outcomes:**

After successful completion of this course, the students can able to

- CO1: Acquire Knowledge about the moulding machines and casting processes
- CO2: Knowledge about various heat treatments and Bulk Deformation Processes,
- CO3: Understand the forging and non-conventional machining processes
- CO4: Describe the Manufacturing of Plastic components
- CO5: Demonstrate the theory of metal cutting and Powder Metallurgy.

**Prerequisites:**

NIL



1021233110	<b>Manufacturing Technology I</b>	L	T	P	C
THEORY		3	0	0	3

### CO/PO Mapping

CO/PO	P01	P02	P03	P04	P05	P06	P07
<b>C01</b>	3	2	2	3	1	1	
<b>C02</b>	2	1	2	3	1	1	
<b>C03</b>	2	3	3	3			
<b>C04</b>	2	3	3	3	1	1	
<b>C05</b>	3	2	2	2	1	1	

Legend:3-HighCorrelation, 2-MediumCorrelation, 1-LowCorrelation

### Instructional Strategy

- It is advised that teachers take steps to pique pupils' attention and boost their learning confidence.
- To help students learn and appreciate numerous concepts and principles in each area, teachers should provide examples from daily life, realistic situations and real- world engineering and technological applications.
- The demonstration can make the subject exciting and foster in the students a scientific mindset. Student activities should be planned on all the topics.
- Throughout the course, a theory-demonstrate-practice-activity strategy may be used to ensure that learning is outcome-and employability-based.
- All demonstrations/Hand-on practices are under a simulated environment (may be followed by a real environment as far as possible).



1021233110	<b>Manufacturing Technology I</b>	L	T	P	C
THEORY		3	0	0	3

### Assessment Methodology

	Continuous Assessment (40 marks)				End Semester Examination (60 marks)
	CA1	CA2	CA3	CA4	
<b>Mode</b>	Written test (Two units)	Written test (Another Two units)	Quiz MCQ (Online / Offline)	Model Examination	Written Examination
<b>Duration</b>	2 Periods	2 Periods	1 Hour	3 Hours	3 Hours
<b>Exam Marks</b>	50	50	60	100	100
<b>Converted to</b>	15	15	5	20	60
<b>Marks</b>	15		5	20	60
<b>Tentative Schedule</b>	6th Week	12th Week	13-14th Week	16th Week	

**CA1 and CA2:** Assessment written test should be conducted for 50 Marks for two units. The marks scored will be converted to 15 Marks. Best of one will be considered for the internal assessment of 15 Marks.

CA1 and CA2, Assessment test should be conducted for two units as below.

Answer five questions (5 X 10 Marks = 50 Marks).

Eight questions will be asked, students should write Five questions. Each unit Four questions can be asked. Each question may have subdivisions. Maximum two subdivisions shall be permitted.



1021233110	<b>Manufacturing Technology I</b>	L	T	P	C
THEORY		3	0	0	3

**CA3:** 60 MCQ can be asked by covering the entire portion. It may be conducted by Online /Offline. The answer scripts of every student (online / offline) for this assessment should be kept for records and future verification. The marks scored should be converted to 5 marks for the internal assessment

**CA4:** Model examination should be conducted as per the end-semester question pattern. The marks should be converted to 20 marks for the internal assessment.

**Question Pattern:**

Answer Ten questions by selecting two questions from each unit. Each question carries 10 marks each.

Four questions will be asked from every unit, students should write any two questions. The question may have two subdivisions only.



1021233110	<b>Manufacturing Technology I</b>	L	T	P	C
THEORY		3	0	0	3

### Syllabus Contents

<b>UNIT I</b>	<b>MOULDING MACHINES AND CASTING</b>			
<b>1.1: Moulding Machines:</b>	Construction and working principle of Jolt machine, Squeezer and Sand slinger. Core – core sand – properties. CO <sub>2</sub> process -core making. Construction and working principle of Cupola furnace.			7
<b>1.2: Casting:</b>	Shell mould casting – investment casting – pressure die casting – hot chamber die casting – cold chamber die casting – gravity die casting – centrifugal casting – continuous casting - defects in casting – causes and remedies.			
<b>UNIT II</b>	<b>HEAT TREATMENT AND PRESS WORKING.</b>			
<b>2.1: Heat treatment:</b>	Heat treatment processes–purpose–procedures–applications of various heat treatment processes– Iron – carbon equilibrium diagram – full annealing – normalizing–hardening–tempering – quenching medium–flame hardening.			7
<b>2.2: Press working:</b>	Press working: Types of presses–Mechanical and Hydraulic presses – press working operations – bending operations–angle bending – chemical bending – curling – drawing – shearing operations – blanking, piercing, trimming – notching – lancing.			
<b>UNIT III</b>	<b>FORGING AND NON-CONVENTIONAL MACHINING PROCESSES.</b>			
<b>3.1: Forging:</b>	Hot working, cold working – advantages of hot working and cold working– hot working operations – rolling, forging, smith forging, drop forging, upset forging, press forging – roll forging.			7



1021233110	<b>Manufacturing Technology I</b>	L	T	P	C
THEORY		3	0	0	3

**3.2: Non-Conventional Machining Processes:**  
 Construction, working, advantages, disadvantages and applications of Ultrasonic machining-chemical machining-electro chemical grinding-electrical discharge machining-plasma arc machining-LASER machining.

**UNIT IV | MANUFACTURING OF PLASTIC COMPONENTS**

**4.1: Plastic Components:**  
 Types of plastics-Engineering plastics – thermosets – composite - structural foam, elastomers - polymer alloys and liquid crystal polymers

**4.2: Factors Influencing The Selection Of Plastics:**  
 Mechanical properties – degradation- wear resistance -frictional properties- special properties - processing.

**4.3: Processing of Plastics:**  
 Extrusion-general features of single screw extrusion -twin screw extruders and types-Injection moulding- types: Plunger type.-Reciprocating screw injection - details of injection mould -sandwich moulding - gas injection moulding - injection moulding of thermosetting materials calendaring and rotational moulding.

**UNIT V | THEORY OF METAL CUTTING AND POWDER METALLURGY**

**5.1: Theory of metal cutting:**  
 Introduction – orthogonal cutting – oblique cutting - single point cutting tool – nomenclature – types of chips – chip breakers – cutting tool materials – properties – tool wears – factors affecting tool life – cutting fluids – functions – properties of cutting fluid.

**5.2: Powder Metallurgy:**  
 Methods of manufacturing metal powders– atomization, reduction and electrolysis deposition–compacting–sintering–sizing–infiltration– mechanical properties of Parts made by powder metallurgy–design rules for the powder metallurgy process.

<b>Test + Revision</b>	10
<b>Total</b>	45



1021233110	<b>Manufacturing Technology I</b>	L	T	P	C
THEORY		3	0	0	3

**Suggested list of Student Activities**

1. Prepare the green sand mould for the solid pattern.
2. Prepare the green sand mould for the split pattern.
3. Study and prepare a report about plastic injection moulding.
4. Prepare the list of materials and its uses in Automobile vehicles.

**Text book for Reference:**

1. Elements of workshop Technology Volume I & II – Hajra Chowdry & Bhattacharaya - II<sup>th</sup> Edition - Media Promoters & Publishers Pvt. Ltd.
2. Introduction of basic manufacturing processes and workshop technology – Rajendersingh – New age International (P) Ltd. Publishers.
3. Production Technology – HMT - Edn. 18 - published by Tata McGraw Hill publishing Co. Ltd.
4. Manufacturing Technology, Volume II, Fourth Edition, P N Rao, McGraw Hill Education (india) Private Limited. Sixth reprint 2024.

**Web-based/Online Resources:**

- <https://nptel.ac.in/courses/112/107/112107219/>
- <https://nptel.ac.in/courses/112/107/112107144/>
- <https://nptel.ac.in/courses/112/105/112105127/>



1021233110	<b>Manufacturing Technology I</b>	L	T	P	C
THEORY		3	0	0	3

**END SEMESTER QUESTION PATTERN - Theory Exam**

**Duration: 3 Hrs.**

**Max. Marks: 100**

**Note:** Answer Ten questions by selecting two questions from each unit. Each question carries 10 marks each.

**Instruction to the Question Setters**

Four questions will be asked from every unit, students should write any two questions for 10 marks. The question may have two subdivisions only.



1021233230	<b>AUTOMOTIVE ENGINES</b>	L	T	P	C
PRACTICUM		2	0	2	3

**Introduction:**

This is the core technology subject. All automotive vehicles are powered by IC engines. Hence the fundamental knowledge of automobile engines is most essential for the auto technicians. This subject will help in understanding the procedure of inspection, diagnosis and testing of engines and other systems. This subject deals with all systems in automobile engines.

**Course Objectives:**

- To Learn Thermodynamic Systems, Thermodynamic Laws & Thermodynamic Cycle.
- To learn about the construction and working fundamentals of IC Engines and its components
- To learn the working principle of the fuel system of petrol and diesel engines.
- To learn the lubrication & cooling systems of engines.
- To learn the performance parameters of IC engines.

**Course Outcomes:**

On successful completion of this course, the students will be able to

- C01: Understand the various thermodynamic systems and various components of the IC engine.
- C02: Gain knowledge about the fundamentals of IC engine construction and working principle.
- C03: Identify and differentiate fuel systems in petrol and diesel engines.
- C04: Realize the importance of lubrication & cooling systems.
- C05: Understand the engine performance parameter.

**Prerequisites:**

NIL



1021233230	<b>AUTOMOTIVE ENGINES</b>	L	T	P	C
PRACTICUM		2	0	2	3

### CO/PO Mapping

CO / PO	P01	P02	P03	P04	P05	P06	P07
C01	2	2	1	2	3	1	
C02	3		2	2	3	1	
C03	3		2	3	3	1	
C04	2	2	2	3	2	1	
C05	1		2		1		

Legend: 3-High Correlation, 2-Medium Correlation, 1-Low Correlation

### Assessment Methodology:

	Continuous Assessment (40 marks)				End Semester Examination (60 marks)
	CA1	CA2	CA3	CA4	
<b>Mode</b>	Written Test Theory (Any Two Units)	Written Test Theory (Another Two Units)	Practical Test (All Exercises)	Written Test (Complete Theory Portions)	Written Examination (Complete Theory Portions)
<b>Duration</b>	2	2	3	3 Hours	3 Hours
<b>Exam Marks</b>	50	50	100	100	100
<b>Converted to</b>	10	10	15	15	60
<b>Marks</b>	10		15	15	60
<b>Tentative Schedule</b>	6th Week	12th Week	15th Week	16th Week	



1021233230	<b>AUTOMOTIVE ENGINES</b>	L	T	P	C
PRACTICUM		2	0	2	3

Note:

- **CA1 and CA2:** Assessment written test should be conducted for 50 Marks. The marks scored will be converted to 10 Marks for each test. The best of one will be considered for the internal assessment of 10 Marks.

CA1 and CA2, Assessment written test should be conducted for two units as below.

Answer any Five questions. (5 X 10 Marks = 50 Marks).

Eight questions will be asked, students should write Five questions.

In each unit, Four questions can be asked. Each question may have subdivisions. A maximum of two subdivisions shall be permitted.

- **CA 3:** All the exercises/experiments should be completed and kept for the practical test. The students shall be permitted to select any one by lot for the test. The practical test should be conducted as per the scheme of evaluation as below. The marks awarded for 100 marks will be converted to 15 Marks for the internal mark.

Practical documents should be maintained for every exercise/experiment immediately after completion of the practice.

The practical document should be submitted for the practical test. Each exercise/experiment should be evaluated for 10 Marks. The total marks awarded should be converted to 30 Marks for the practical test as per the scheme of evaluation as below.

**The details of the practical documents are to be prepared as per the instructions below.**

Each exercise / experiment procedure, observation and calculations should be completed on the day of practice. The same shall be evaluated for 10 marks on the day or the next day of practice before the commencement of the next exercise.

This documentation can be carried out in a separate notebook or a printed manual or a file with documents. The observation, reading, calculations, report, graphs and results should be written by the student manually in the practical documents.

The evaluated practical document should be submitted for the Practical Test (CA3). The marks scored by the students should be converted to 30 marks. The same should be included as per the allocation in the practical test.



1021233230	<b>AUTOMOTIVE ENGINES</b>	L	T	P	C
PRACTICUM		2	0	2	3

The detailed dates of the practices and its evaluations should be maintained in the course logbook. The log book and the practical documents should be submitted for the verification by the Flying Squad and DOTE Official.

#### SCHEME OF EVALUATION - Practical Test

PART	Description	Marks
A	Aim / Tools required	10
B	Procedure / Observation / Dismantle	20
C	Assemble / Sketch / Components list	20
D	Result / Report	10
E	Practical document (All Practicals)	30
F	Viva Voce	10
Total		100

**CA4:** Model examination should be conducted for complete theory portions as per the end-semester question pattern. The marks awarded should be converted to 15 marks for the internal assessment.

#### Question Pattern:

Answer Ten questions by selecting two questions from each unit. Each question carries 10 marks each.

Four questions will be asked, students should write any two questions from every unit. The question may have two subdivisions only.



1021233230	<b>AUTOMOTIVE ENGINES</b>	L	T	P	C
PRACTICUM		2	0	2	3

### Syllabus Contents

<b>Unit I</b>	<b>THERMODYNAMIC, ENGINE FUNDAMENTALS</b>			
<b>Theory:</b>	Thermodynamic System – Types of Thermodynamic System – Zeroth Law of Thermodynamics, First law of thermodynamic, Second Law of Thermodynamic – Thermodynamic cycles – Carnot Cycle, Otto Cycles, Diesel Cycle, P V & T S Diagrams (Description only) - Heat Engine - Basic Engine Terminology - Types of Engines - Classification of IC Engines - IC Engine and its Components - Construction and Working Principle of SI engines- 2 Stroke & 4 Stroke Engines - Construction and Working Principle of CI Engines- 2 Stroke & 4 Stroke Engines.			6
<b>Practical:</b>	1. Dismantle & Assemble an Engine and Identify the Various Parts. 2. Draw The Port Timing a two stroke Petrol Engine. 3. Draw The Valve Timing Diagram of a four stroke Petrol or Diesel Engine.			6
<b>Unit II</b>	<b>PETROL ENGINE FUEL SUPPLY SYSTEM</b>			
<b>Theory:</b>	SI Engine Fuel Feed System - Gravity and Pump Feed System - Construction & Working of Mechanical Fuel Pump and Electrical Fuel Pump - Air Filters – Types -Stoichiometric Air Fuel Ratio - Air & Fuel Mixtures and its Requirement -Construction & Working of Simple Carburetor, Solex Carburetor, SU Carburetor – SI Engine Fuel Injection System Classification - Construction & Working of MPFI System - Advantages & Disadvantages.			6
<b>Practical:</b>	4. Dismantle & Assemble a Carburetor and Check the Parts, Sketch the Various Circuits. 5. Identify the MPFI System Components and Draw the Layout.			4



1021233230	<b>AUTOMOTIVE ENGINES</b>	L	T	P	C
PRACTICUM		2	0	2	3

<b>Unit III</b>	<b>DIESEL ENGINE FUEL SUPPLY SYSTEM</b>			
<b>Theory:</b>	Requirement of Fuel Injection System - Various Components of Diesel Fuel Injection System - Diesel Feed Pumps - Diesel Injection Pumps - Fuel Injectors – Nozzles – Governor - Construction & Working of Mechanical Governor & Pneumatic Governor – Construction & Working of Modern Common Rail Fuel Injection System – Cold Starting Devices.			
	6			
<b>Practical:</b>	6. Dismantle & Assemble injection pump and injectors. Study the spray pattern of various injectors. 7. Identify the common rail fuel injection System Components and Draw the Layout.			
	5			
<b>Unit IV</b>	<b>ENGINE COOLING SYSTEM &amp; LUBRICATION SYSTEM</b>			
<b>Theory:</b>	Necessity of Cooling System - Types of Cooling Systems - Construction and Working of Thermosiphon Cooling System, Pump Circulation Cooling System – Radiator - types of Radiator Cores - Properties of Coolants, Antifreeze Solution – Types - Purpose of Using Additives. Purpose of lubrication system - properties of engine lubricating oil - classifications of lubricants and their makes - Grading of lubricants - additives for lubricants - types of lubrication – petro oil lubrication, wet sump lubrication, dry sump lubrication, splash lubrication, pressurized lubrication system - causes of oil consumption and oil contamination - crankcase ventilation - Types.			
	6			
<b>Practical:</b>	8. Change the suitable grade engine oil for petrol or Diesel engine. 9. Top-up or change the engine coolant for the petrol or Diesel engine.			
	5			



1021233230	<b>AUTOMOTIVE ENGINES</b>	L	T	P	C
PRACTICUM		2	0	2	3

Unit V	ENGINE PERFORMANCE, SUPERCHARGING	
Engine performance parameters – Engine Torque, Brake Power, Indicated Power, Frictional Power, Mean Effective Pressure, Fuel Consumption, Specific Fuel Consumption – Engine Efficiency – Indicated Thermal Efficiency, Brake Thermal Efficiency, Mechanical Efficiency, Air Standard Efficiency, Volumetric Efficiency, Air Fuel Ratio, Relative Air Fuel Ratio, Description only – Morse Test Procedure – Heat Balance Sheet – Effect of Temperature and Attitude on Engine Power – Performance and Characteristics Curves. Supercharging – Need of Supercharging – Types of Supercharger – Turbocharger - Construction & Working of Turbocharger.		6
Test + Revision		10
Total		60

**List of Student activities:**

1. Study and prepare a report about the cooling system of a vehicle with layout.
2. Draw the layout and components list of the CRDI system.
3. Draw the layout and components list of the MPFI system.
4. List the coolants and lubricants used for the LMV.

**Text book for Reference:**

1. R.K.Rajput, Thermal Engineering, 11 th Edition, Laxmi publications Pvt Ltd. 2020.
2. Dr.Kirpal Singh, Automobile Engineering Vol 1& 2, 14 th , Standard Publisher Distributors, Delhi, 2021.
3. M.L.Mathur & R.P.Sharma, Internal Combustion engines, 8th edition, Dhanpat Rai & Sons, 2010.



1021233230	<b>AUTOMOTIVE ENGINES</b>	L	T	P	C
PRACTICUM		2	0	2	3

**Web-based/Online Resources:**

- [https://www.youtube.com/watch?v=85K4\\_4PfRpQ%20&list=PL1b9Ht9ISqIG\\_szHgF6Fie9fdDpf8W0E0](https://www.youtube.com/watch?v=85K4_4PfRpQ%20&list=PL1b9Ht9ISqIG_szHgF6Fie9fdDpf8W0E0)
- <https://youtu.be/NpII017XBMI>
- <https://youtu.be/hs7bABMtOMI>



1021233230	<b>AUTOMOTIVE ENGINES</b>	L	T	P	C
PRACTICUM		2	0	2	3

**LIST OF EQUIPMENT / TOOLS / MACHINERY'S REQUIRED**

Sl. No.	Machinery's / Equipment / Tools	Quantity
1	Petrol Engine or Diesel Engine for Dismantle & Assemble	01
2	Two-stroke petrol engine cut section	01
3	Four-stroke petrol or diesel engine cut section.	01
4	Carburetor	01
5	MPFI Kit	01
6	Injector and injection pump	01
7	CRDI Kit	01
8	Four-wheeler	01
9	Two-wheeler	01
10	Basic and special tools	sufficient quantity
11	Service tools	sufficient quantity
12	Consumables	sufficient quantity



1021233230	<b>AUTOMOTIVE ENGINES</b>	L	T	P	C
PRACTICUM		2	0	2	3

**END SEMESTER QUESTION PATTERN - Theory Exam**

**Duration: 3 Hrs.**

**Max. Marks: 100**

**Note:** Answer Ten questions by selecting two questions from each unit. Each question carries 10 marks each.

**Instruction to the Question Setters**

Four questions will be asked from every unit, students should write any two questions for 10 marks. The question may have two subdivisions only.



1021233340	<b>Mechanics of Materials</b>	L	T	P	C
PRACTICUM		1	0	4	3

### Introduction

Day by day Engineering and Technology experiences tremendous growth. Design plays a major role in developing engineering and technology. Mechanics of material are the backbone for design. Mechanics of material deals generally with the behaviour of material, when they are subjected to actions of forces. Evaluations derived from these, provide the tools for investigation of mechanical structure.

### Course Objectives

- The objective of this course is to enable the student to
- Understand the deformation of materials, when they are subjected to load and conduct material testing on hardness and shear test and acquire skills on different types of testing methods of metals.
- Familiarize the stress strain diagram and able to handle UTM
- Determine modulus of rigidity of open coil spring and closed coil spring.
- Determine the Rigidity modulus of the material of circular shafts using torsion testing machine
- Estimate the stresses induced in thin cylindrical and spherical shells.

### Course Outcomes

After successful completion of this course, the students can able to

CO 1: Understand the material testing procedure for hardness, shear etc.

CO 2: Describe stress strain diagram and handle UTM .

CO 3: Find out modulus of rigidity of open coil spring and closed coil spring by using spring testing machine.

CO 4: Handle torsion testing machine and find out modulus of rigidity of shaft materials.

CO 5: Determine stresses induced in thin cylindrical and spherical shells.

### Pre-requisites

NIL



1021233340	<b>Mechanics of Materials</b>	L	T	P	C
PRACTICUM		1	0	4	3

### CO/PO Mapping

CO/PO	P01	P02	P03	P04	P05	P06	P07
<b>C01</b>	3	2	2	3	1		
<b>C02</b>	2	1	2	3	1		
<b>C03</b>	2	3	3	3	1		
<b>C04</b>	2	3	3	3	1		
<b>C05</b>	3	2	2	2	1		

Legend: 3-HighCorrelation, 2-MediumCorrelation, 1-LowCorrelation

### Instructional Strategy

- It is advised that teachers take steps to pique pupils' attention and boost their learning confidence.
- To help students learn and appreciate numerous concepts and principles in each area, teachers should provide examples from daily life, realistic situations and real-world engineering and technological applications.
- The demonstration can make the subject exciting and foster in the students a scientific mindset. Student activities should be planned on all the topics.
- Throughout the course, a theory-demonstrate-practice-activity strategy may be used to ensure that learning is outcome-and employability-based.
- All demonstrations/Hands-on practices are under a simulated environment (may be followed by a real environment as far as possible).



1021233340	<b>Mechanics of Materials</b>	L	T	P	C
PRACTICUM		1	0	4	3

**Assessment Methodology:**

	Continuous Assessment (40 marks)				End Semester Examination (60 marks)
	CA1	CA2	CA3	CA4	
<b>Mode</b>	Practical Test	Practical Test	Written Test Theory	Practical Test	Practical Examination
<b>Portion</b>	Cycle I Exercises	Cycle II Exercises	All Units	All Exercises	All Exercises
<b>Duration</b>	2 Periods	2 Periods	3 Hours	3 Hours	3 hours
<b>Exam Marks</b>	60	60	100	100	100
<b>Converted to Marks</b>	10	10	15	15	60
<b>Marks</b>	10		15	15	60
<b>Tentative Schedule</b>	7th Week	14th Week	15th Week	16th Week	

Note:

- **CA1 and CA2:** All the exercises/experiments should be completed as per the portions above and kept for the practical test. The students shall be permitted to select any one by lot for the test. The practical test should be conducted as per the scheme of evaluation as below. The marks awarded shall be converted to 10 Marks for each assessment test. Best of one will be considered for the internal assessment of 10 Marks.

Practical documents should be maintained for every exercise / experiment immediately after completion of the practice. The practical document should be submitted for the practical test. The same should be evaluated for 10 Marks for each exercise/experiment.



1021233340	<b>Mechanics of Materials</b>	L	T	P	C
PRACTICUM		1	0	4	3

The total marks awarded should be converted to 10 Marks for the practical test as per the scheme of evaluation as below.

**The details of the practical documents are to be prepared as per the instructions below.**

Each exercise / experiment procedure, observation and calculations should be completed on the day of practice. The same shall be evaluated for 10 marks on the day or the next day of practice before the commencement of the next exercise.

This documentation can be carried out in a separate notebook or a printed manual or a file with documents. The observation, reading, calculations, report, graphs and results should be written by the student manually in the practical documents.

The evaluated practical document should be submitted for the Practical Test (CA3). The marks scored by the students should be converted to 10 marks. The same should be included as per the allocation in the practical test.

The detailed dates of the practices and its evaluations should be maintained in the course logbook. The log book and the practical documents should be submitted for the verification by the Flying Squad and DOTE Official.

#### SCHEME OF EVALUATION

PART	DESCRIPTION	MARKS
A	Aim / Apparatus required	10
B	Procedure / Observation	20
C	Calculations	20
TOTAL		50
D	Practical Documents (As per the portions)	10
		60

**Cycle I:** 1, 2, 3, 4 and 5.

**Cycle II:** 6, 7, 8, 9 and 10.



1021233340	<b>Mechanics of Materials</b>	L	T	P	C
PRACTICUM		1	0	4	3

- **CA 3:** Written Test for complete theory portions should be conducted for 100 Marks as per the question pattern below. The marks scored will be converted to 15 Marks for internal assessment.

#### Question pattern – Written Test Theory

Description		Marks	
Part – A	30 MCQ from the complete theory portions	30 X 1 Mark	30 Marks
Part – B	Seven Questions to be answered out of 10 Questions.	7 X 10 Marks	70 Marks
TOTAL			100 Marks

- **CA 4:** All the exercises/experiments should be completed and kept for the practical test. The students shall be permitted to select any one by lot for the test. The practical test should be conducted as per the scheme of evaluation below. After completion of all the exercises, the practical test should be conducted as per the End-Semester Examination question pattern scheme of evaluation. The marks awarded should be converted to 15 Marks for the internal assessment.

#### SCHEME OF EVALUATION

##### Model Practical Examination and End Semester Examination - Practical Exam

PART	DESCRIPTION	MARKS
A	Aim / Apparatus required	10
B	Procedure / Observation	20
C	Calculations	20
D	Result / Graph	10
E	Written Test (Theory Portions only)	30
F	Viva Voce	10
TOTAL		100

**Note:** For the written test 30 MCQ shall be asked from the theory portions.



1021233340	<b>Mechanics of Materials</b>	L	T	P	C
PRACTICUM		1	0	4	3

### Theory Contents

<b>Chapter 1</b>	<b>MECHANICAL PROPERTIES OF MATERIALS</b>			
Introduction-Importance of mechanical properties of materials. Definition and brief explanation of mechanical properties - elasticity, plasticity, stiffness, ductility, malleability, brittleness, toughness, hardness, wear resistance, machinability, weldability and cast ability.				3
<b>Chapter 2</b>	<b>SIMPLE STRESS AND STRAIN &amp; MATERIAL TESTING</b>			
Introduction – Definition of load, stress and strain - classification of forces - tensile, compressive, shear, bending and torsional forces - stress strain diagram of ductile material - limit of proportionality. Hooks law - elastic limit - yield point - breaking point - ultimate stress- Definition only. Elastic Constant: Modulus of elasticity, Bulk modulus and Rigidity modulus – definition only. Relation between E, N and K – equations only. Destructive and non-destructive testing – Description only.				5
<b>Chapter 3</b>	<b>SPRING</b>			
Introduction - Spring - Types of spring – applications of springs in automobiles – Types of coiled springs – Difference between open and closely coiled helical springs. Experimental procedure and its calculations.				3
<b>Chapter 4</b>	<b>THEORY OF TORSION</b>			
Introduction –assumptions in the theory of pure torsion – torsion equation (no derivation) - Strength of solid and hollow shafts – power transmitted. Definition of Polar modulus, polar moment of inertia. – Torsional rigidity – strength and stiffness of shafts – comparison of hollow and solid shafts – Advantages of hollow shafts over solid shafts.				4



1021233340	<b>Mechanics of Materials</b>	L	T	P	C
PRACTICUM		1	0	4	3

<b>PRACTICAL</b>		
<b>Ex. No.</b>	<b>Name of the Exercise</b>	
1	Determine the Rockwell hardness or Brinell hardness number for various materials such as HSS, mild steel, copper and aluminium (Any Two). Compare the results to identify the hardest material.	5
2	Determine the impact energy and specific impact factor for ductile materials by (i) Charpy Impact test and (ii) Izod impact test.	5
3	Conduct a tensile test for a ductile material and determine the following; i) Ultimate tensile stress. ii) Yield stress. iii) Breaking stress. iv) % Elongation. v) Young's modulus. vi) % Reduction in area.	5
4	Determine ultimate shear strength in single shear for a ductile material.	5
5	Determine ultimate shear strength in double shear for a ductile material.	5
6	Determine the modulus of rigidity of the material of the open coil spring.	5
7	Determine the modulus of rigidity of the material of the Closed coil spring.	5
8	Prepare and mount the specimen (Ferrous or Non-ferrous material) and Check the microstructure of the given specimens by using a metallurgical microscope.	5
9	Determine the behavior of Mild steel when subjected to Torsion and calculate the following torsional properties: (1) Modulus of rigidity (2) Elastic shear strength.	5
10	Detect the surface or subsurface crack of the given ferromagnetic material using dye penetration test and magnetic particle test	5
Practice + Test + Revision		10
<b>TOTAL HOURS</b>		<b>75</b>



1021233340	<b>Mechanics of Materials</b>	L	T	P	C
PRACTICUM		1	0	4	3

**Suggested list of students activity**

1. Students shall prepare hardness number table for different metals
2. Prepare young's modulus values tables for different materials
3. Prepare a report about the destructive and Non destructive Tests.
4. Study about the microscope and its applications.
5. Prepare a chart about the various materials microstructure.

**Text book for Reference:**

1. Strength of Materials, R. S. Khurmi, S.Chand & Co., Ram Nagar, New Delhi.
2. Strength of Materials, S. Ramamrutham, 15th Edition 2004, DhanpatRai Pub. Co.,New Delhi.
3. Strength of Materials, R.K. Bansal, Laxmi Publications Pvt. Ltd., New Delhi, 3 rd Edition, 2010.

**Web-based/Online Resources:**

- <https://youtu.be/mMNE0U17v-E?si=gaHRXIMXhZEcMkFv>
- [https://youtu.be/Ry9X\\_O8is-k?si=0va1nL9qt\\_qBmyn](https://youtu.be/Ry9X_O8is-k?si=0va1nL9qt_qBmyn)
- <https://youtu.be/gRu7q4t06Gc?si=hZHRQVi4sKYh20U5>
- <https://youtu.be/gX0-PhTu0QE?si=EkneQcyfOBkpit9v>



1021233340	<b>Mechanics of Materials</b>	L	T	P	C
PRACTICUM		1	0	4	3

### END SEMESTER EXAMINATIONS – PRACTICAL EXAM

**Note:**

All the exercises / experiments should be completed before the Board Practical Examinations. End Semester Practical examination should be conducted for all the exercises / experiments for 100 Marks. Students will be permitted to select any one exercise by lot or question paper supplied by the DOTE Exam section shall be used.

The Practical Documents by the student should be submitted with a Bonafide Certificate.

PART	DESCRIPTION	MARKS
A	Aim / Apparatus required	10
B	Procedure / Observation	20
C	Calculations	20
D	Result / Graph	10
E	Written Test (Theory Portions only)	30
F	Viva Voce	10
TOTAL		100

**Note:** For the written test 30 MCQ shall be asked from the theory portions.



1021233340	<b>Mechanics of Materials</b>	L	T	P	C
PRACTICUM		1	0	4	3

### LIST OF EQUIPMENTS

Sl. No	Name of the Exercise	Quantity
1	Rockwell hardness or Brinell hardness Tester	1
2	Charpy Impact test and Izod impact test.	1
3	UTM 1. Tension test arrangement 2. Single shear arrangement 3. Double shear arrangement	1
4	Open coil spring tester.	1
5	Closed coil spring tester.	1
6	Metallurgical microscope.	1
7	Specimen mounting machine	1
8	Polishing machine	1
9	Torsion test rig.	1
10	Dye penetration test kit.	1
11	Magnetic particle test kit.	1
12	Consumable and Instruments	Required quantity



1021233440	<b>Automotive Electrical and Electronics Systems</b>	L	T	P	C
PRACTICUM		1	0	4	3

**Introduction:**

To Impart Knowledge to the Students in the principles, constructional details and Operation Details of Various Automotive Electrical & Electronic Components and Systems – Batteries, Charging System, Starting System, Ignition System, Lighting System and Auxiliary System and Electronic Management Vehicle.

**Course Objectives:**

To understand the complete procedure of construction/dismantling, cleaning, and inspection, fault finding/rectifying and reassembling of components of automobile electrical and electronic systems

**Course Outcomes:**

On successful completion of this course, the student will be able to

- CO1: Identify and test the Battery system.
- CO2: Apply the procedure for testing of alternator and starting system.
- CO3: Select and test the various wiring circuits of automobiles.
- CO4: Describe the Sensors, ignition and ECM.
- CO5: Test and diagnose the Sensors and Ignition System.

**Pre-requisites:**

NIL



1021233440	<b>Automotive Electrical and Electronics Systems</b>	L	T	P	C
PRACTICUM		1	0	4	3

### CO/PO Mapping

CO / PO	P01	P02	P03	P04	P05	P06	P07
<b>C01</b>	1	2	-	1	-	-	-
<b>C02</b>	1	1	-	2	-	-	-
<b>C03</b>	1	1	-	2	-	-	-
<b>C04</b>	1	-	-	-	-	-	-
<b>C05</b>	2	2	-	2	-	-	-

Legend: 3-High Correlation, 2-Medium Correlation, 1-Low Correlation

### Instructional Strategy:

- It is advised that teachers take steps to pique pupils' attention and boost their curiosity to learn.
- Implement task-based learning activities where students work on specific tasks or projects.
- Incorporate technology tools and resources, such as online platforms, online courses (NPTEL, SWAYAM, etc ), interactive multimedia, and virtual communication tools, to enhance engagement and provide additional practice opportunities.
- Incorporate formative and summative assessments to gauge student progress and provide targeted feedback.
- Throughout the course, a theory-demonstrate-practice-activity strategy may be used to ensure that learning is outcome and employability-based.
- All demonstrations/Hands-on practices may be followed in the real environment as far as possible.



1021233440	<b>Automotive Electrical and Electronics Systems</b>	L	T	P	C
PRACTICUM		1	0	4	3

**Assessment Methodology:**

	Continuous Assessment (40 marks)				End Semester Examination (60 marks)
	CA1	CA2	CA3	CA4	
<b>Mode</b>	Practical Test	Practical Test	Written Test Theory	Practical Test	Practical Examination
<b>Portion</b>	Cycle I Exercises	Cycle II Exercises	All Units	All Exercises	All Exercises
<b>Duration</b>	2 Periods	2 Periods	3 Hours	3 Hours	3 hours
<b>Exam Marks</b>	60	60	100	100	100
<b>Converted to Marks</b>	10	10	15	15	60
<b>Marks</b>	10		15	15	60
<b>Tentative Schedule</b>	7th Week	14th Week	15th Week	16th Week	

Note:

- **CA1 and CA2:** All the exercises/experiments should be completed as per the portions above and kept for the practical test. The students shall be permitted to select any one by lot for the test. The practical test should be conducted as per the scheme of evaluation as below. The marks awarded shall be converted to 10 Marks for each assessment test. Best of one will be considered for the internal assessment of 10 Marks.

Practical documents should be maintained for every exercise / experiment immediately after completion of the practice. The practical document should be submitted for the practical test. The same should be evaluated for 10 Marks for each exercise/experiment.



1021233440	<b>Automotive Electrical and Electronics Systems</b>	L	T	P	C
PRACTICUM		1	0	4	3

The total marks awarded should be converted to 10 Marks for the practical test as per the scheme of evaluation as below.

**The details of the practical documents are to be prepared as per the instructions below.**

Each exercise / experiment procedure, observation and calculations should be completed on the day of practice. The same shall be evaluated for 10 marks on the day or the next day of practice before the commencement of the next exercise.

This documentation can be carried out in a separate notebook or a printed manual or a file with documents. The observation, reading, calculations, report, graphs and results should be written by the student manually in the practical documents.

The evaluated practical document should be submitted for the Practical Test (CA3). The marks scored by the students should be converted to 10 marks. The same should be included as per the allocation in the practical test.

The detailed dates of the practices and its evaluations should be maintained in the course logbook. The log book and the practical documents should be submitted for the verification by the Flying Squad and DOTE Official.

#### SCHEME OF EVALUATION

PART	DESCRIPTION	MARKS
A	Aim / Apparatus required	10
B	Procedure / Observation	20
C	Calculations	20
TOTAL		50
D	Practical Documents (As per the portions)	10
		60

**Cycle I:** 1, 2, 3, 4 and 5.

**Cycle II:** 6, 7, 8, 9 and 10.



1021233440	<b>Automotive Electrical and Electronics Systems</b>	L	T	P	C
PRACTICUM		1	0	4	3

- **CA 3:** Written Test for complete theory portions should be conducted for 100 Marks as per the question pattern below. The marks scored will be converted to 15 Marks for internal assessment.

#### Question pattern – Written Test - Theory

Description		Marks	
Part – A	30 MCQ from the complete theory portions	30 X 1 Mark	30 Marks
Part – B	Seven Questions to be answered out of 10 Questions.	7 X 10 Marks	70 Marks
TOTAL			100 Marks

- **CA 4:** All the exercises/experiments should be completed and kept for the practical test. The students shall be permitted to select any one by lot for the test. The practical test should be conducted as per the scheme of evaluation below. After completion of all the exercises, the practical test should be conducted as per the End-Semester Examination question pattern scheme of evaluation. The marks awarded should be converted to 15 Marks for the internal assessment.

#### SCHEME OF EVALUATION

##### Model Practical Examination and End Semester Examination - Practical Exam

PART	DESCRIPTION	MARKS
A	Aim / Apparatus required	10
B	Procedure / Observation	20
C	Calculations	20
D	Result / Graph	10
E	Written Test (Theory Portions only)	30
F	Viva Voce	10
TOTAL		100

**Note:** For the written test 30 MCQ shall be asked from the theory portions.



1021233440	<b>Automotive Electrical and Electronics Systems</b>	L	T	P	C
PRACTICUM		1	0	4	3

### Syllabus contents

<b>Battery and Starting System</b>	
<b>Theory</b> Battery – Types – Construction and Working of Lead Acid Battery – Battery Testing – Specific Gravity, Load Test and Open volt testing.	2
<b>Practical Exercises</b> <b>Experiment 1:</b> Battery Testing – Specific Gravity Test, Open volt testing, Cell voltage tester.	5
<b>Theory</b> Starting Motor – Working Principle – Construction, Bendix Drive Mechanism. Alternators – Working Principle –Construction. Starting System Circuit. Solenoid Actuator, Relays and types of Relays and their automotive usage.	3
<b>Practical Exercises</b> <b>Experiment 2:</b> Testing of Alternator Parts such as Stator, Rotor and Rectifier for Resistance, Continuity for Insulation Effectiveness using Multifunction Tester.	5
<b>Experiment 3:</b> Testing of Starter Motor Parts such as Test Field Windings, Brush Holders, Armature and Solenoid Switch for Continuity Using a Multifunction Tester	5
<b>Experiment 4:</b> Construct and test the starting and charging circuit.	5
<b>Lighting and Auxiliary System</b>	
<b>Theory</b> Lighting system – circuit – Headlight – Aiming and adjustment – sealed beam headlights – directional signal circuits – fluorescent lamp - Horn circuits – Windscreen wiper. Glass Panel Operating System,	3
<b>Practical Exercises</b> <b>Experiment 5:</b> Construction and Testing of Head Lights, Parking Lights and Direction Indicators Circuit and adjust the headlight position.	5
<b>Experiment 6:</b> Construction and Testing of Horn and wiper circuit.	5



1021233440	<b>Automotive Electrical and Electronics Systems</b>	L	T	P	C
PRACTICUM		1	0	4	3

<b>Experiment 7:</b> Identify and Test the music system and power window.	5
<b>Theory</b> Gauges - Fuel Gauge, Oil Pressure Gauge, Coiling Water Temperature Gauge and Ammeter Charging Indicator.	2
<b>Practical Exercises</b> <b>Experiment 8:</b> Construction and Testing of Fuel and Temperature Gauges Circuit.	5
<b>Ignition and Engine Management Systems</b>	
<b>Theory</b> Electronic ignition systems – Transistorised Coil Ignition – Capacitive Discharge Ignition – Computer controlled coil ignition systems. Importance of ignition timing and ignition advance.	2
<b>Practical Exercises</b> <b>Experiment 9:</b> Test the electronic ignition and electronic Fuel injection system.	5
<b>Theory</b> Types of Sensors – Thermistor Sensor, Pressure Sensor, Inductive Sensor, Knock Sensor, Fuel Flow Sensor, Oxygen Sensor and Vehicle Speed Sensor. Electronic Control Unit - Working Principle. Sub-Units in Microprocessor Control Systems. Microprocessor And Microcomputer Controlled Devices In Automobiles.	3
<b>Practical Exercises</b> <b>Experiment 10:</b> Testing of various Sensors using a Multifunction Tester. Pressure Sensor, Knock Sensor, Oxygen Sensor, Engine crankshaft angular position sensor, and Vehicle Speed Sensor.	5
Revision + Test + Practice	10
<b>Total</b>	<b>75</b>

**Suggested List of Students Activity:**

- Poster presentation on the complete electrical wiring system of a four-wheeler with electric wire colour coding.
- Presentation /Seminar on ECM & error codes diagnosis.



1021233440	<b>Automotive Electrical and Electronics Systems</b>	L	T	P	C
PRACTICUM		1	0	4	3

**Text book for Reference:**

1. A.K Babu, Automobile Electrical and Electronics, Khanna Book Publishing Co.(P) Ltd, 2nd edition, 2017.
2. P.L Kohli, Automobile Electrical Equipment, McGraw Hill Education, 1st edition, 2017.
3. Tom Denton, Automobile Electrical and Electronics Systems, Routledge; 5th edition, 2017.

**Web-based/Online Resources:**

- NPTEL:: Engineering Design - NOC: Fundamentals of Automotive Systems  
<https://archive.nptel.ac.in/courses/107/106/107106088/>



1021233440	<b>Automotive Electrical and Electronics Systems</b>	L	T	P	C
PRACTICUM		1	0	4	3

**Equipment / Facilities required to conduct the Practical Course.**

Sl. No.	Machinery's / Equipment / Tools	Quantity
1.	Lead acid battery	4 No's
2.	Specific gravity tester	2 No's
3.	Cell voltage tester	1 No
4.	Starting and charging system	1 No
5.	Alternator	2 No's
6.	Starter Motor	2 No's
7.	Headlight with adjustment setup	1 No
8.	Parking Light	1 No
9.	Direction Indicator	1 Set
10.	Horn	1 No
11.	Wiper Motor	1 No
12.	Fuel gauge	1 No
13.	Temperature gauge	1 No
14.	Electronic Fuel Ignition Systems	1 No
15.	Engine crankshaft angular position sensor	1 No
16.	Speed sensor	1 No
17.	Pressure sensor	1 No
18.	Knock sensor	1 No
19.	Oxygen sensor	1 No
20.	Digital Multimeter	3 No's
21.	Four-wheeler with music system & power window setup	1 No
22.	Consumable and Instruments	Required quantity



1021233440	<b>Automotive Electrical and Electronics Systems</b>	L	T	P	C
PRACTICUM		1	0	4	3

### END SEMESTER EXAMINATIONS – PRACTICAL EXAM

**Note:**

All the exercises / experiments should be completed before the Board Practical Examinations. End Semester Practical examination should be conducted for all the exercises / experiments for 100 Marks. Students will be permitted to select any one exercise by lot or question paper supplied by the DOTE Exam section shall be used.

The Practical Documents by the student should be submitted with a Bonafide Certificate.

PART	DESCRIPTION	MARKS
A	Aim & Apparatus Required	10
B	Procedure	20
C	Sketch / Connections / Report	20
D	Result	10
E	Written Test (Theory Portions only)	30
F	Viva Voce	10
TOTAL		100

**Note:** For the written test 30 MCQ shall be asked from the theory portions.



1021233540	<b>Automobile Engineering Drawing</b>	L	T	P	C
PRACTICUM		1	0	4	3

**Introduction:**

Diploma Engineer is expected to possess a thorough understanding of drawing, which includes clear visualization and proficiency in reading and interpreting a wide variety of automobile production drawing. Manufacturing of various automobile parts starts from the basic drawing of components. The assembly of components is also carried out from the drawing. So drawing is an important subject to be studied by the students to carry and complete the Automobile component production and assembly process successfully.

**Course Objectives:**

- Appreciate the need for a sectional view and types of sections.
- Compare the hole basis system with the shaft basis system.
- Select different types of fits and tolerance for various types of mating parts.
- Explain the use of threaded fasteners and the types of threads.
- Explain the Riveted joints, different types of rivet heads and joints.
- Explain the Keys and select different types keys
- Explain the Surface roughness and it's important for production of Machine Elements
- Practice on manual drawing
- Practice on AutoCAD commands in making 2D drawings.
- Draw assembled drawings of different types of joints and couplings using AutoCAD
- Draw assembled drawings of various Automobile components using AutoCAD.

**Course Outcomes:**

C01 - Understand of sectioning of the objects and different types of sections are representing the sectional views.

C02 - Apply limits and appropriate fits for given tolerances to component assemblies.

C03 - Ability to select the Screwed fasteners, Keys and Riveted joints

C04 - Acquire the knowledge of Engineering drawings and standards to prepare standard dimensioned drawings of machine parts and automobile components

C05 - Prepare part drawing and assembly drawings using AutoCAD software as per industrial Standards.



1021233540	<b>Automobile Engineering Drawing</b>	L	T	P	C
PRACTICUM		1	0	4	3

**Pre-requisites:**

- Fundamental concepts of Engineering Drawing.
- Basic knowledge in the creation of orthographic drawings and assembly drawing with standards.
- Knowledge in basic mathematics, unit measurement, visualization and imagination capabilities.
- Fundamental concepts and components of Automobile Engineering.

**CO/PO Mapping**

CO / PO	P01	P02	P03	P04	P05	P06	P07
<b>C01</b>	1	1	2	-	-	-	-
<b>C02</b>	-	1	1	2	-	-	-
<b>C03</b>	-	1	2	-	-	-	-
<b>C04</b>	2	1	3	1	-	-	1
<b>C05</b>	2	1	3	2	-	-	1

Legend: 3-High Correlation, 2-Medium Correlation, 1-Low Correlation



1021233540	<b>Automobile Engineering Drawing</b>	L	T	P	C
PRACTICUM		1	0	4	3

**Assessment Methodology:**

	Continuous Assessment (40 marks)				End Semester Examination (60 marks)
	CA1	CA2	CA3	CA4	
<b>Mode</b>	Practical Test	Practical Test	Written Test Theory	Practical Test	Practical Examination
<b>Portion</b>	Manual Drawing & CAD Drawing (Ex 1, 2 & 3)	Manual Drawing & CAD Drawing (Ex 4, 5 & 6)	All Units	Manual Drawing & CAD Drawing All Exercises	All Exercises
<b>Duration</b>	2 Periods	2 Periods	3 Hours	3 Hours	3 hours
<b>Exam Marks</b>	60	60	100	100	100
<b>Converted to Marks</b>	10	10	15	15	60
<b>Marks</b>	10		15	15	60
<b>Tentative Schedule</b>	7th Week	14th Week	15th Week	16th Week	

Note:

- **CA1 and CA2:** All the exercises/experiments should be completed as per the portions above and kept for the practical test. The students shall be permitted to select any one by lot for the test. The practical test should be conducted as per the scheme of evaluation as below. The marks awarded shall be converted to 10 Marks for each assessment test. Best of one will be considered for the internal assessment of 10 Marks.

Practical documents should be maintained for every exercise / experiment immediately after completion of the practice. The practical document should be submitted for the



1021233540	<b>Automobile Engineering Drawing</b>	L	T	P	C
PRACTICUM		1	0	4	3

practical test. The same should be evaluated for 10 Marks for each exercise/experiment. The total marks awarded should be converted to 10 Marks for the practical test as per the scheme of evaluation as below.

**The details of the practical documents are to be prepared as per the instructions below.**

Each exercise / experiment the manual assemble drawing or CAD practice should be completed on the day of practice. The same shall be evaluated for 10 marks on the day or the next day of practice before the commencement of the next exercise.

This documentation can be carried out in a file with documents. The manual assembled drawing view in the drawing sheet (6 Exercises) and the CAD printout of the assembled view (6 Exercises) should be kept as the practical document. All the documents should be the output of the practices of every student. It should not be a common printout. The evaluated practical document should be submitted for the Practical Test (CA3) as per the portions. The marks scored by the students should be converted to 10 marks. The same should be included as per the allocation in the practical test.

The detailed dates of the practices and its evaluations should be maintained in the course logbook. The log book and the practical documents should be submitted for the verification by the Flying Squad and DOTE Official.

#### SCHEME OF EVALUATION

PART	DESCRIPTION	MARKS
A	Manual Assembled Drawing - Sectional Front View / Half sectional Front view - Drawing Sheet	25
B	CAD Assembled 2D Views with Dimensions. (Sectional Front View / Half sectional Front View)	25
TOTAL		50
C	Practical Documents (As per the portions)	10
		60



1021233540	<b>Automobile Engineering Drawing</b>	L	T	P	C
PRACTICUM		1	0	4	3

- **CA 3:** Written Test for complete theory portions should be conducted for 100 Marks as per the question pattern below. The marks scored will be converted to 15 Marks for internal assessment.

**Question pattern – Written Test Theory**

Description		Marks	
Part – A	30 One Mark questions (MCQ) should be answered.	30 X 1 Mark	30 Marks
Part – B	Seven Ten Marks questions should be answered from Ten questions.	7 X 10 Marks	70 Marks
TOTAL			100 Marks

- **CA 4:** All the exercises/experiments should be completed and kept for the practical test. The students shall be permitted to select any one by lot for the test. The practical test should be conducted as per the scheme of evaluation below. After completion of all the exercises, the practical test should be conducted as per the End Semester Examination question pattern scheme of evaluation. The marks awarded should be converted to 15 Marks for the internal assessment.



1021233540	<b>Automobile Engineering Drawing</b>	L	T	P	C
PRACTICUM		1	0	4	3

### MODEL EXAMINATIONS

All the exercises should be given in the question paper and students are allowed to select by a lot.

PART	DESCRIPTION	MARKS
A	Manual Assemble Drawing - Sectional Front View / Half sectional Front view - Drawing Sheet	25
B	CAD Assemble 2D Views with Dimensions. (Sectional Front View / Half sectional Front View)	25
C	Neatness / Printout	10
D	Written Test (Theory Portions only)	30
E	Viva Voce	10
TOTAL		100

**Note:** For the written test 30 MCQ shall be asked from the theory portions.



1021233540	<b>Automobile Engineering Drawing</b>	L	T	P	C
PRACTICUM		1	0	4	3

### Syllabus Contents - Theory Portions

<b>UNIT - I</b>	<b>LIMITS, FITS AND TOLERANCES</b>			
Introduction – Definition of various terms used in limits – Hole basis system – Shaft basis system – Types of fits – Selection of fits and applications – types of tolerances – form and position – Indication of tolerances and fits on the drawing.				3
<b>UNIT - II</b>	<b>SCREW THREADS , THREADED FASTENERS AND RIVETED JOINTS</b>			
Temporary and permanent fasteners - applications – Nuts and Bolts - through bolt – tap bolt, stud bolt – set screw – cap screws – machine screws – foundation bolts – Screws - Screw thread – Nomenclature – different types of thread profiles – threads in sections – threaded fasteners different types of locking arrangements of nuts. Riveted joints Different types of rivet heads for general purposes - proportions of riveted joints - Different types of riveted joints - single riveted and double riveted lap joint (Chain and zigzag), single riveted single strap butt joint and single riveted double strap butt joint.				10
<b>UNIT - III</b>	<b>KEYS AND SURFACE TEXTURE</b>			
Keys – classification of keys – Heavy duty keys – light duty keys. Surface roughness – representation of surface roughness on drawings.				2

### Practical Portions

**8 Periods**

#### **PART A: INTRODUCTION ENGINEERING DRAWING**

Requirements of drawing, drawing views – front view – top view - side view, section plane, sectional views – conventions of section lines, conventional representation of machine parts, production drawing.

#### **PART B: INTRODUCTION TO CAD SOFTWARE - Assemble views**

Information about CAD, Draw / sketch tools, Modify / Edit tools. Drawing detailed parts drawings – assembling the parts – 2D Views – printout.



1021233540	<b>Automobile Engineering Drawing</b>	L	T	P	C
PRACTICUM		1	0	4	3

<b>PRACTICAL EXERCISES</b>		
<b>Ex.No</b>	<b>Name of the Exercise</b>	<b>Hours</b>
1	Knuckle joint.	7
2	Universal coupling.	7
3	Screw jack.	7
4	Piston with piston pin assembly.	7
5	Connecting rod assembly.	7
6	Balanced Crankshaft assembly.	7
Practice + Continuous Test + Revision		10
<b>TOTAL HOURS</b>		<b>60</b>

**Text book for Reference:**

1. Gopalakrishna K R, "Machine Drawing", Subhas Publishing, 2012.
2. K C John and P I Varghese, "Machine Drawing", Jovast Publishers, Thrissur, 2013.
3. K L Narayana and P Kannaiah, "Machine Drawing", New Age International Publishers, 2013.
4. R.N.Bhal "Automobile Design", I.K. International Publishing House Pvt. Limited, 2019.

**Web-based/Online Resources:**

- <https://archive.nptel.ac.in/courses/112/102/112102304/>
- <https://archive.nptel.ac.in/courses/112/105/112105294/>
- <https://archive.nptel.ac.in/courses/112/105/112105125/>



1021233540	<b>Automobile Engineering Drawing</b>	L	T	P	C
PRACTICUM		1	0	4	3

### END SEMESTER EXAMINATIONS – PRACTICAL EXAM

**Note:**

All the exercises / experiments should be completed before the Board Practical Examinations. End Semester Practical examination should be conducted for all the exercises / experiments for 100 Marks. Students will be permitted to select any one exercise by lot or question paper supplied by the DOTE Exam section shall be used.

The Practical Documents by the student should be submitted with a Bonafide Certificate.

PART	DESCRIPTION	MARKS
A	Manual Assemble Drawing - Sectional Front View /Half sectional Front view - Drawing Sheet	25
B	CAD Assemble 2D Views with Dimensions. (Sectional Front View / Half sectional Front View)	25
C	Neatness / Printout	10
D	Written Test (Theory Portions only)	30
E	Viva Voce	10
TOTAL		100

**Note:** For the written test 30 MCQ shall be asked from the theory portions.

#### LIST OF EQUIPMENT

1. Personal computer – 30 Nos.
2. Printer – 1 No.
3. Required Software's: CAD Package – Sufficient to the strength.



1021233540	<b>Automobile Engineering Drawing</b>	L	T	P	C
PRACTICUM		1	0	4	3

## EXERCISE DRAWINGS



**DIRECTORATE OF TECHNICAL EDUCATION, CHENNAI – 600 025  
REGULATION 2023**

1021233540	<b>Automobile Engineering Drawing</b>	L	T	P	C
PRACTICUM		1	0	4	3

**Exercise - 1**  
From the details of a KNUCKLE JOINT shown in Figure.

All Dimensions are in mm

PART NO	DESCRIPTION	MATERIAL	NO OFF
5	TAPER PIN	Fe-410W	1
4	COLLAR	Fe-410W	1
3	PIN	Fe-410W	1
2	EYE	Fe-410W	1
1	FORK	Fe-410W	1

ALL UNMENTIONED FILLETS AND ROUNDS R=3mm



1021233540	<b>Automobile Engineering Drawing</b>	L	T	P	C
PRACTICUM		1	0	4	3

**Exercise - 2**  
1) From the details of a UNIVERSAL COUPLING shown in Figure.

PART NO	DESCRIPTION	MATERIAL	NO OFF
7	TAPER PIN	Fe-410W	2
6	COLLAR	Fe-410W	2
5	PIN	Fe-410W	2
4	PARALLEL KEY	Fe-410W	2
3	SHAFT	Fe-410W	2
2	CENTRE	CAST IRON	1
1	FORK	CAST STEEL	2

All Dimensions are in mm

ALL UNDIMENSIONED FILLETS AND ROUNDS RADI 3mm



1021233540	<b>Automobile Engineering Drawing</b>	L	T	P	C
PRACTICUM		1	0	4	3

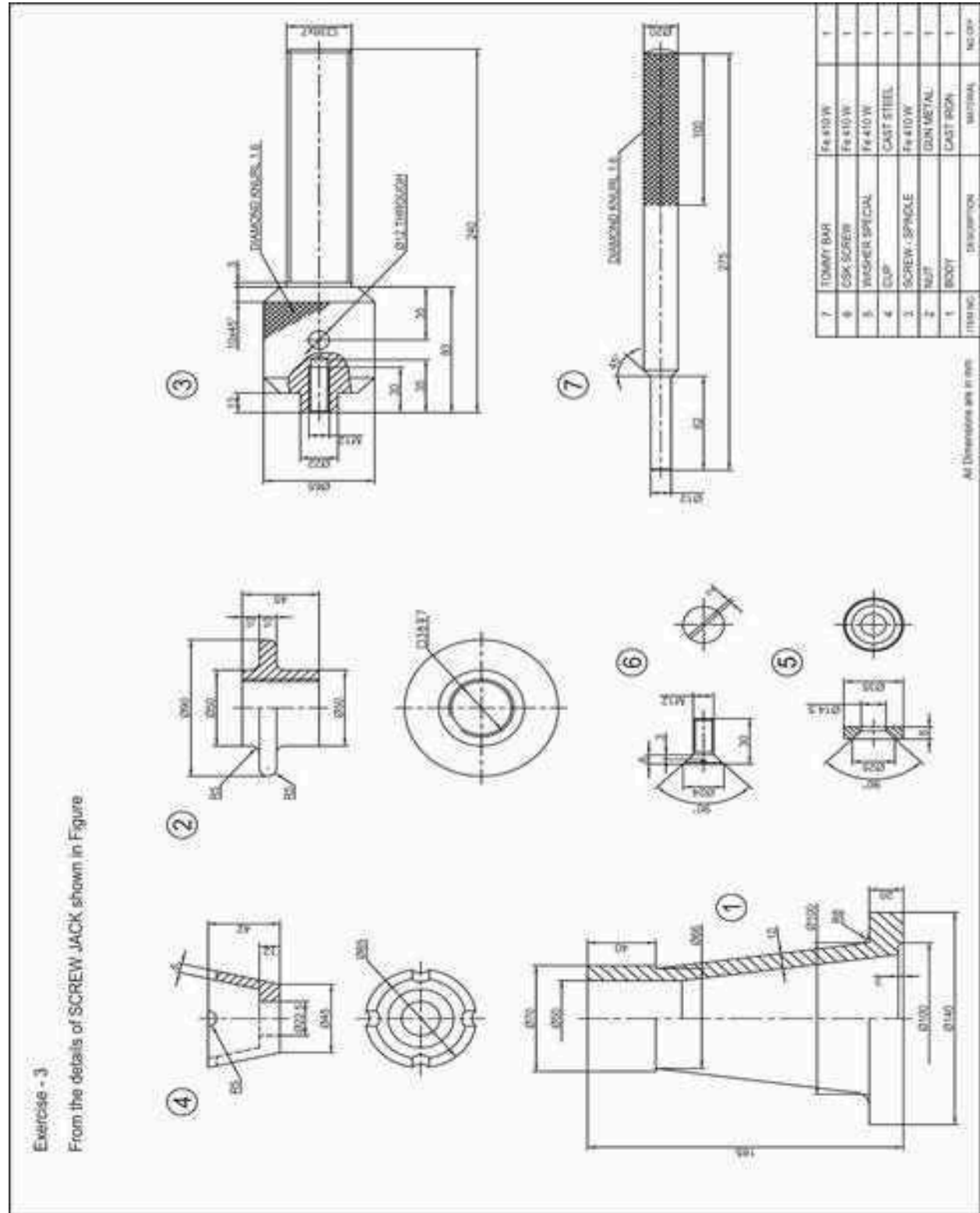

1021233540	<b>Automobile Engineering Drawing</b>	L	T	P	C
PRACTICUM		1	0	4	3

**Exercise No - 4**  
From the details of a PISTON WITH PISTON PIN ASSEMBLY, shown in Figure.

ITEM NO.	DESCRIPTION	MATERIAL	NO OFF
4	PISTON RING	CI	5
3	PISTON PIN PLUG	HCS	2
2	PISTON PIN	HCS	1
1	PISTON	AL-ALLOY	1

All Dimensions are in mm



1021233540	<b>Automobile Engineering Drawing</b>	L	T	P	C
PRACTICUM		1	0	4	3

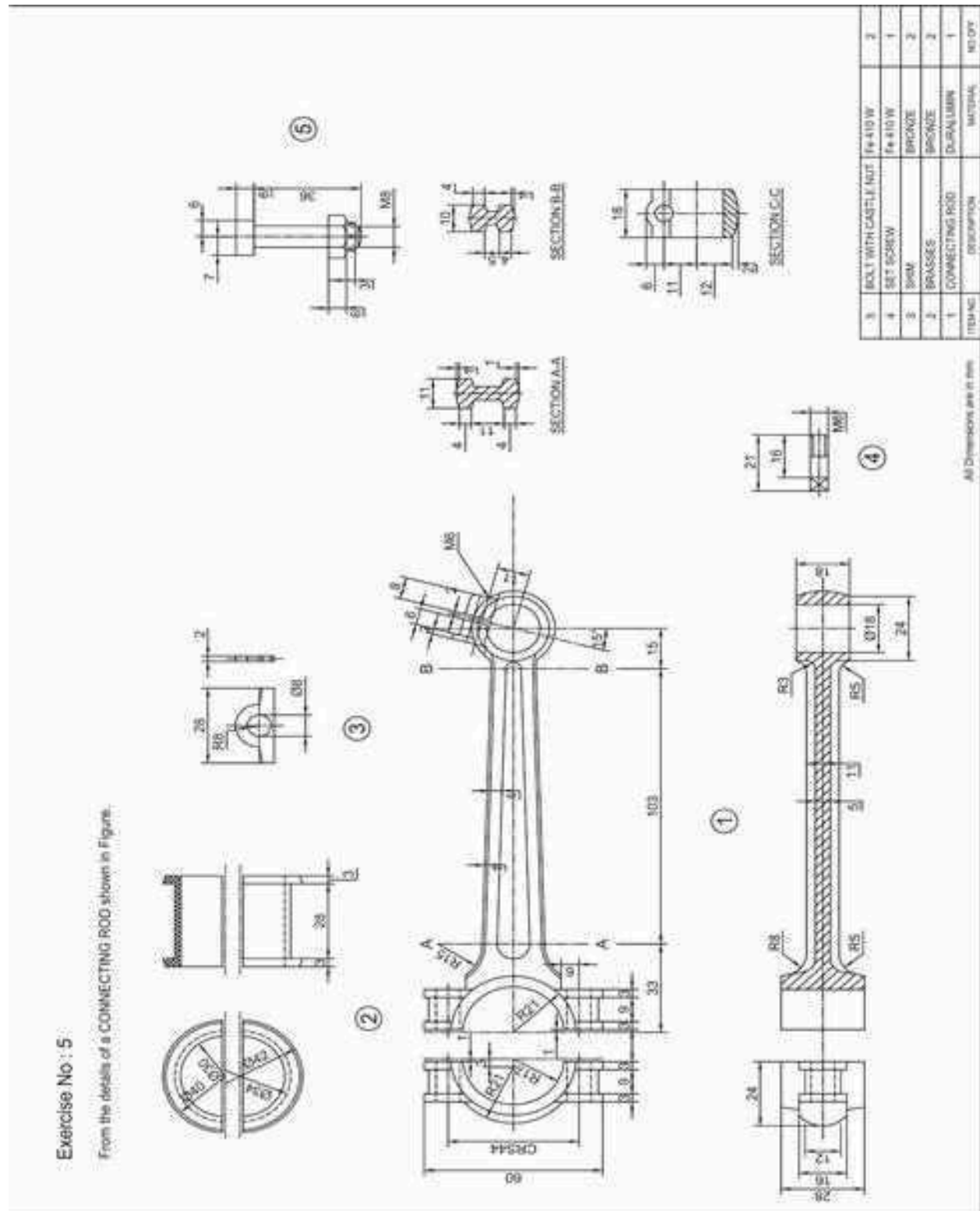

1021233540	<b>Automobile Engineering Drawing</b>	L	T	P	C
PRACTICUM		1	0	4	3

Exercise - 6  
From the details of the BALANCED CRANKSHAFT shown in the figure

All Dimensions are in mm

PART NO	DESCRIPTION	MATERIAL	NO/OFF
5	BUSH	RUBBER	4
4	FLYWHEEL MOUNTING FLANGE	CI	4
3	MAIN JOURNAL	CI	NA
2	COUNTER WEIGHTS	CI	NA
1	CRANK PIN JOURNAL	CI	NA



1021233640	<b>Fluid Power Systems</b>	L	T	P	C
PRACTICUM		1	0	4	3

**Introduction:**

The purpose of this course is to teach the fundamentals of hydraulics and pneumatics in a more general manner so that they can understand the way that forces are generated and transmitted by fluids at rest and also in motion. Hydraulic and Pneumatic systems simplify the power transmission, enhancement of force and torque and provide a high degree of automation. This is a major technical course. It provides construction of hydraulic and pneumatic circuits and their applications in industrial and automobile systems and its maintenance.

**Course Objectives:**

- To study the basics of fluid properties, types of flow and the transmission of pressure in liquids and its application to hydraulics.
- To learn about the loss of heads due to friction and minor losses in flow through pipes.
- To understand the working of pumps like centrifugal and reciprocating.
- To identify the various components of a Hydraulic and Pneumatic systems.
- To study about the design of hydraulic and pneumatic circuits for engineering applications.

**Course Outcomes:**

On successful completion of this course, the student will be able to

C01: Use principles of fluid mechanics for energy conversion.

C02: Analysis the losses of flow through pipes

C03: Evaluate the capacity of centrifugal and reciprocating pumps.

C04: Maintain the components of hydraulic and pneumatic systems

C05: Construct hydraulic and pneumatic circuits for relevant applications.

**Pre-requisites:**

Nil



1021233640	<b>Fluid Power Systems</b>	L	T	P	C
PRACTICUM		1	0	4	3

**CO/PO Mapping**

CO / PO	P01	P02	P03	P04	P05	P06	P07
<b>C01</b>	2	1	-	1	1	-	1
<b>C02</b>	2	2	-	2	1	-	1
<b>C03</b>	2	1	-	2	1	-	1
<b>C04</b>	1	1	-	1	1	-	1
<b>C05</b>	3	2	2	2	1	2	1

Legend: 3-High Correlation, 2-Medium Correlation, 1-Low Correlation

**Instructional Strategy:**

- It is advised that teachers take necessary steps to pique pupils' attention and improve their curiosity to learn.
- Throughout the course, a theory-demonstrate-practice-activity strategy may be used to ensure that outcome based learning and employability based.



1021233640	<b>Fluid Power Systems</b>	L	T	P	C
PRACTICUM		1	0	4	3

**Assessment Methodology:**

	Continuous Assessment (40 marks)				End Semester Examination (60 marks)
	CA1	CA2	CA3	CA4	
<b>Mode</b>	Practical Test	Practical Test	Written Test Theory	Practical Test	Practical Examination
<b>Portion</b>	Cycle I Exercises	Cycle II Exercises	All Units	All Exercises	All Exercises
<b>Duration</b>	2 Periods	2 Periods	3 Hours	3 Hours	3 hours
<b>Exam Marks</b>	60	60	100	100	100
<b>Converted to Marks</b>	10	10	15	15	60
<b>Marks</b>	10		15	15	60
<b>Tentative Schedule</b>	7th Week	14th Week	15th Week	16th Week	

Note:

- **CA1 and CA2:** All the exercises/experiments should be completed as per the portions above and kept for the practical test. The students shall be permitted to select any one by lot for the test. The practical test should be conducted as per the scheme of evaluation as below. The marks awarded shall be converted to 10 Marks for each assessment test. Best of one will be considered for the internal assessment of 10 Marks.

Practical documents should be maintained for every exercise / experiment immediately after completion of the practice. The practical document should be submitted for the practical test. The same should be evaluated for 10 Marks for each exercise/experiment. The total marks awarded should be converted to 10 Marks for the practical test as per the scheme of evaluation as below.



1021233640	<b>Fluid Power Systems</b>	L	T	P	C
PRACTICUM		1	0	4	3

**The details of the practical documents are to be prepared as per the instructions below.**

Each exercise / experiment procedure, observation and calculations should be completed on the day of practice. The same shall be evaluated for 10 marks on the day or the next day of practice before the commencement of the next exercise.

This documentation can be carried out in a separate notebook or a printed manual or a file with documents. The Observation, reading, calculations, report, graphs and results should be written by the student manually in the practical documents.

The evaluated practical document should be submitted for the Practical Test (CA3). The marks scored by the students should be converted to 10 marks. The same should be included as per the allocation in the practical test.

The detailed dates of the practices and its evaluations should be maintained in the course logbook. The log book and the practical documents should be submitted for the verification by the Flying Squad and DOTE Official.

#### SCHEME OF EVALUATION

PART	DESCRIPTION	MARKS
A	Aim & Apparatus Required	10
B	Observation / Formulae	20
C	Execution / Calculations	20
TOTAL		50
D	Practical Documents (As per the portions)	10
		60

**Cycle I:** 1, 2, 3, 4 and 5

**Cycle II:** 6, 7, 8, 9 and 10.



1021233640	<b>Fluid Power Systems</b>	L	T	P	C
PRACTICUM		1	0	4	3

- **CA 3:** Written Test for complete theory portions should be conducted for 100 Marks as per the question pattern below. The marks scored will be converted to 15 Marks for internal assessment.

#### Question pattern – Written Test Theory

Description		Marks	
Part – A	30 MCQ from the complete theory portions	30 X 1 Mark	30 Marks
Part – B	Seven Questions to be answered out of 10 Questions.	7 X 10 Marks	70 Marks
TOTAL			100 Marks

- **CA 4:** All the exercises/experiments should be completed and kept for the practical test. The students shall be permitted to select any one by lot for the test. The practical test should be conducted as per the scheme of evaluation below. After completion of all the exercises, the practical test should be conducted as per the End Semester Examination question pattern scheme of evaluation. The marks awarded should be converted to 15 Marks for the internal assessment.

#### SCHEME OF EVALUATION

##### Model Practical Examination and End Semester Examination - Practical Exam

PART	DESCRIPTION	MARKS
A	Aim & Apparatus Required	10
B	Observation / Circuit	20
C	Calculations	20
D	Output / Graphs / Result	10
E	Written Test (Theory Portions only)	30
F	Viva Voce	10
TOTAL		100

**Note:** For the written test 30 MCQ shall be asked from the theory portions.



1021233640	<b>Fluid Power Systems</b>	L	T	P	C
PRACTICUM		1	0	4	3

### Syllabus Contents

<b>Theory Portion – UNIT I</b>	
<p><b>Properties of fluid:</b>            Properties of fluid Introduction –Definition of Fluid - Properties of Fluid – Density, Specific Weight, Specific Volume, Specific gravity - Viscosity, Absolute Viscosity, Kinematics Viscosity, Compressibility, adhesion, Cohesion, surface tension and capillarity.</p> <p><b>Fluid Static:</b>            Fluid Static Fluid pressure at a point - Pascal’s Law - Application – Hand-operated Hydraulic Jack and Hydraulic Press. Pressure head atmospheric, gauge, vacuum and absolute pressures.</p>	6
<p><b>Practical Exercises</b></p> <p>Ex.No: 1 Verify Bernoulli's Theorem.            Ex.No: 2 Determination of coefficient of discharge of a venturimeter (or) orificemeter.            Ex.No: 3. Determination of the friction factor in a pipe.            Ex.No: 4. Performance test on the centrifugal pump and draw the characteristics curve.            Ex.No: 5. Performance test on the reciprocating pump and draw the characteristics curve.</p>	25



1021233640	<b>Fluid Power Systems</b>	L	T	P	C
PRACTICUM		1	0	4	3

<b>Theory Portion – UNIT II</b>	
<p><b>Hydraulic system:</b> Valves: Pressure Control valves – pressure relief valve, pressure reducing valve, pressure unloading valve. Direction control valve – poppet valve, spool valve, 3/2, 4/2 &amp; 4/3 DC valves, sequencing valve. Flow control valve – pressure compensated – non-pressure compensated. Actuators – Linear actuators – single acting &amp; double acting – rotary actuators – hydraulic motors. Accessories – Intensifiers and Accumulators.</p> <p><b>Pneumatic system:</b> Types, construction, working Principle and symbol of the following components. Compressor – Reciprocating &amp; Rotary Compressors. Actuators – Linear actuators – single acting &amp; double acting – rotary actuators – air motors. Accessories. FRL unit. Double-acting cylinder with Meter in, Meter out circuits, speed control circuit and sequencing circuit</p>	8
<p><b>Practical Exercises</b></p> <p>Ex.No: 6. Speed control of a double-acting cylinder using metering-in circuits. Ex.No: 7. Speed control of a double-acting cylinder using metering-out circuits. Ex.No: 8. Automatic operation of a double-acting cylinder in a single cycle - using limit switch. Ex.No: 9. Direct operation of a double-acting hydraulic cylinder. Ex.No: 10. Direct operation of hydraulic motor.</p>	25
Test + Revision	10
Total	75



1021233640	<b>Fluid Power Systems</b>	L	T	P	C
PRACTICUM		1	0	4	3

**Suggested List of Students Activity:**

- Advised to collect the different methods of pipe joints
- Advised to prepare troubleshooting charts for different defects of pumps.
- Advised to prepare specifications of pump and compressor for specific applications
- Advised to collect the scheduled maintenance data relevant to hydraulics and pneumatics from industries and bus depot.

**Text book for Reference:**

1. R. K. Bansal, A Textbook of Fluid Mechanics and Hydraulic Machines, Laxmi Publications (P)., Ltd, New Delhi, 2010.
2. R. K Rajput, A Textbook of Fluid Mechanics, S.Chand & Co, New Delhi, 2019.
3. Shanmugasundaram.K, Hydraulic and Pneumatic Controls, Chand & Co, 2006.

**Web-based/Online Resources:**

- <http://nptel.ac.in>
- <https://youtu.be/-SQvrrzIAac?si=0o27IbDwd5CuZ-cN>
- <https://youtu.be/LxLCJITK4TY?si=84jnqPxWKuoW6-IZ>
- <https://youtu.be/BStvG3EYurg?si=ZGG4HqA3ELdVaT1g>



1021233640	<b>Fluid Power Systems</b>	L	T	P	C
PRACTICUM		1	0	4	3

**Equipment / Facilities required to conduct the Practical Course.**

1. The Bernoulli's Apparatus – 01 No.
2. An arrangement of Venturi Meter or Orifice Meter fitted in horizontal water pipe line to find coefficient of discharge. – 01 No.
3. An arrangement to find the friction factor of different pipes. - 01 No.
4. A centrifugal pump with an arrangement for collecting data to find out the efficiency and plot the characteristics curves. - 01 No.
5. A reciprocating pump with an arrangement for collecting data to find out the efficiency and plot the characteristics curves. - 01 No.
6. Pneumatic Trainer Kit – 2 Nos. (Board to fix the components as per the circuit. Components should not be permanently fixed.  
(Cylinders, Control Valves, Limit switches and other accessories separately supplied)
7. Hydraulics Trainer Kit – 2 Nos.(Board to fix the components as per the circuit. Components should not be permanently fixed.  
(All Cylinders, Control Valves, Limit switches and other accessories separately supplied)
8. Consumables and instruments - required quantity.



1021233640	<b>Fluid Power Systems</b>	L	T	P	C
PRACTICUM		1	0	4	3

### END SEMESTER EXAMINATIONS – PRACTICAL EXAM

**Note:**

All the exercises / experiments should be completed before the Board Practical Examinations. End Semester Practical examination should be conducted for all the exercises / experiments for 100 Marks. Students will be permitted to select any one exercise by lot or question paper supplied by the DOTE Exam section shall be used.

The Practical Documents by the student should be submitted with a Bonafide Certificate.

PART	DESCRIPTION	MARKS
A	Aim & Apparatus Required	10
B	Observation / Circuit	20
C	Calculations	20
D	Output / Graphs / Result	10
E	Written Test (Theory Portions only)	30
F	Viva Voce	10
TOTAL		100

**Note:** For the written test 30 MCQ shall be asked from the theory portions.



1021234110	<b>Power units and Transmission</b>	L	T	P	C
THEORY		3	0	0	3

**Introduction:**

This subject provides knowledge about the various components of a vehicle and the transmission train used. This subject will also help the students during inspection, installation, operation and maintenance of the transmission system of automobiles. This subject is a core subject for automobile engineers and they should develop desired knowledge and skills over it.

**Course Objectives:**

- To learn about the types of chassis layout, Frames and constructional details of steering.
- To learn about the construction and working Principle of Clutches & Gear boxes.
- To learn about the working of various components of driveline systems.
- To learn about the rear axle drives and suspension systems.
- To learn about the braking systems, wheels and tyres.

**Course Outcomes:**

On successful completion of this course, the students able to

CO1: Identify and understand the various systems, parts of the automobile.

CO2: Understand about the clutch, gearbox and driveline components.

CO3: Select the appropriate rear axle for a given vehicle and know about the various types of wheels and tyres.

CO4: Realize the importance of the braking system in the vehicle and possess knowledge about various brakes.

CO5: Demonstrate safety systems for a vehicle.



1021234110	<b>Power units and Transmission</b>	L	T	P	C
THEORY		3	0	0	3

### CO/PO Mapping

CO / PO	P01	P02	P03	P04	P05	P06	P07
<b>C01</b>	2	1	1	-	-	-	1
<b>C02</b>	2	1	1	-	-	-	1
<b>C03</b>	2	1	1	-	-	-	1
<b>C04</b>	2	1	1	-	-	-	1
<b>C05</b>	2	2	2	2	1	1	2

Legend: 3-High Correlation, 2-Medium Correlation, 1-Low Correlation

### Assessment Methodology

	Continuous Assessment (40 marks)				End Semester Examination (60 marks)
	CA1	CA2	CA3	CA4	
<b>Mode</b>	Written test (Two units)	Written test (Another Two units)	Quiz MCQ (Online / Offline)	Model Examination	Written Examination
<b>Duration</b>	2 Periods	2 Periods	1 Hour	3 Hours	3 Hours
<b>Exam Marks</b>	50	50	60	100	100
<b>Converted to</b>	15	15	5	20	60
<b>Marks</b>	15		5	20	60
<b>Tentative Schedule</b>	6th Week	12th Week	13-14th Week	16th Week	



1021234110	<b>Power units and Transmission</b>	L	T	P	C
THEORY		3	0	0	3

**CA1 and CA2:** Assessment written test should be conducted for 50 Marks for two units. The marks scored will be converted to 15 Marks. Best of one will be considered for the internal assessment of 15 Marks.

CA1 and CA2, Assessment test should be conducted for two units as below.

Answer five questions (5 X 10 Marks = 50 Marks).

Eight questions will be asked, students should write Five questions. Each unit Four questions can be asked. Each question may have subdivisions. Maximum two subdivisions shall be permitted.

**CA3:** 60 MCQ can be asked by covering the entire portion. It may be conducted by Online / Offline. The answer scripts of every student (online / offline) for this assessment should be kept for records and future verification. The marks scored should be converted to 5 marks for the internal assessment

**CA4:** Model examination should be conducted as per the end-semester question pattern. The marks should be converted to 20 marks for the internal assessment.

**Question Pattern:**

Answer Ten questions by selecting two questions from each unit. Each question carries 10 marks each.

Four questions will be asked from every unit, students should write any two questions. The question may have two subdivisions only.

**Theory Contents**

Unit I	CHASSIS, FRONT AXLES, STEERING SYSTEM	
	Chassis – Functions of Chassis Frames – Layout of Chassis and its Main Components - Types of Chassis Layout According to the Engine Location – Types of Frames – Various Frame Sections, Materials – Sub Frames – Load Acting on Vehicle Frame.	9



1021234110	<b>Power units and Transmission</b>	L	T	P	C
THEORY		3	0	0	3

<p>Front Axle Constructions – Live Axle and Dead Axles – Stud Axles – Types. Ackerman’s Steering Mechanisms – Steering Linkage – Steering Geometry – Camber, Caster, Kingpin Inclination, Toe In &amp; Toe Out - Under Steering – Over Steering - Reversible &amp; Irreversible Steering - Turning Radius- Steering Radio- Functions of Steering Gear Box – Recirculating ball, Rack &amp; Pinion Steering Gear Box – Purpose of Power Steering - Hydraulic Power Steering – Electric Power Steering.</p>		
<b>Unit II</b>	<b>CLUTCH &amp; GEAR BOX</b>	
<p>Requirement Of Clutch – Functions Of Clutch – Types Of Clutch - Construction &amp; Working Of Single Plate Clutch, Multiplate Clutch, Centrifugal Clutch, Diaphragm Clutch, Fluid Coupling, Torque Converters – Advantages &amp; Disadvantage - Clutch Facing Materials. Functions Of Gear Box- Gear Ratio – Various Resistance Offered By The Vehicles – Tractive Effort - Types Of Manual Gear Boxes – Construction &amp; Working Of Sliding Mesh Gear Box, Constant Mesh Gear Box, Synchromesh Gear Box – Transfer Case – Automatic Gear Box – Construction &amp; working Of Simple epicyclic gearbox, Continuous Variable Transmission – OverDrive.</p>		9
<b>Unit III</b>	<b>UNIVERSAL JOINTS, PROPELLER SHAFT, FINAL DRIVE, DIFFERENTIAL, REAR AXLES</b>	
<p>Universal Joints – Purpose – Variable Velocity &amp; Constant Velocity Joints – Cross Type, Bendix Weiss type, Rzeppa &amp; Tracta joints. Propeller Shaft – Construction of propeller Shaft – Two Pieces &amp; Three-Piece Propeller Shaft. Final Drive – Purpose of Final Drive – Different Types of Final Drive Gears. Differential Action – Principles of Differential - Construction &amp; Working of Conventional Differential, Differential Lock, Limited Slip Differential. Rear Axles – Load Acting on Drive Axles - Types of Rear axles – semi-floating Axle, full floating Axle, Three Quarter Floating Axle – Compare Semi Floating and Full-Floating axles.</p>		



1021234110	<b>Power units and Transmission</b>	L	T	P	C
THEORY		3	0	0	3

<b>Unit IV</b>	<b>DRIVES &amp; SUSPENSION SYSTEM</b>			
	Rear Axle Drives – Hotchkiss Drive & Torque Tube Drive - Hydrostatic drives – Types of Hydrostatic Drives - Construction & Working of Typical Hydrostatic Drive – Advantages & Disadvantages. Need of suspension system – Types of Suspension System – Rigid Suspension & Independent Suspension – Leaf Springs - Coil Springs -Torsion Bar - Anti Roll Bar – wishbone Suspension - Macpherson Strut Suspension – Swinging Half Axle Suspension – Trailing Link Suspension – Shock Absorbers – Dampers - Construction & Working of Telescopic shock absorber – Air suspension - Construction & Working of Air Suspension System – Active Suspension System.			9
<b>Unit V</b>	<b>BRAKES, WHEELS , TYRES</b>			
	Need of Brakes – Stopping Distance – Types of Brakes - Leading Shoes & Trailing Shoes – Hydraulic Brake System – Master Cylinders – Wheel Cylinders – Bleeding of Brakes – Air Brake System – Disc Brake – Servo brakes – Vacuum Assisted Servo Brakes – Exhaust Brakes – Antilock Brake System – Types. Types of wheels – Disc wheel, Spoked Wheels, Cast Alloy Wheels, Split Wheels Types of Tyres – Conventional Tubed Tyre, Tubeless Tyre –Carcass Types – Cross Ply Tyre, Radial Ply Tyre – compare Cross Ply and Radial Ply Tyres – Run Flat Tyres – Tyre Rotation – Factor Affecting Tyre Life.			9
	TOTAL HOURS			45
	Test + Revision *			15

Note: \* Common test and revision periods (15) can be utilised. (ie) 1 period per week.

**Suggested List of Students Activity:**

Visit any one of the automobile service stations and study the complaints and learn the maintenance procedure to correct the complaints.



1021234110	<b>Power units and Transmission</b>	L	T	P	C
THEORY		3	0	0	3

**Text book for Reference:**

1. R.B. Gupta, Automotive Chassis and Transmission, 2nd, Satya Prakashan, Delhi, 2021.
2. Dr. Kirpal Singh, Automobile Engineering Vol 1 & 2, 14th, Standard Publisher Distributors, Delhi, 2021.
3. Dr V M Domkundwar, Automobile Engineering, 5th, Dhanpat Rai & Co, 2014.

**Web-based/Online Resources:**

- <https://nptel.ac.in/courses/107/106/107106088/>

**END SEMESTER QUESTION PATTERN - Theory Exam**

**Duration: 3 Hrs.**

**Max. Marks: 100**

**Note:** Answer Ten questions by selecting two questions from each unit. Each question carries 10 marks each.

**Instruction to the Question Setters**

Four questions will be asked from every unit, students should write any two questions for 10 marks. The question may have two subdivisions only.



1021234230	<b>Fuels, Combustion and Emission Control</b>	L	T	P	C
PRACTICUM		2	0	2	3

**Introduction:**

Essential components of energy consumption and environmental management in modern society are fuels, combustion, and emission control. The study of different fuel types, their characteristics, combustion processes, and strategies to reduce harmful emissions from combustion activities are all included in this topic. Comprehending these ideas is essential for developing energy-efficient systems, cutting down on pollution, and tackling the issues associated with global climate change.

**Course Objectives:**

- Understand the different kinds of fuel, how to calculate a fuel's calorific value, the details of combustion, and the subtleties of combustion.
- To create awareness of the harmful effects of I.C. engine-related air pollution.
- To study techniques to minimize the toxic gasses released by gas turbine and engine exhaust.
- To Study the multiple regulations and laws in order to reduce air pollution.
- To study the concepts of vehicle pollution, alternate fuels, and control.

**Course Outcomes:**

On successful completion of this course, the student will be able to

CO1: Identify different types of fuels used in combustion processes.

CO2: Explain the laws of thermodynamics and their applications to energy conversion processes.

CO3: Analyze the differences in combustion characteristics between SI and CI engines.

CO4: Identify the components of internal combustion engines, including filters and manifolds.

CO5: Identify key pollution control laws and regulations applicable to combustion processes.



1021234230	<b>Fuels, Combustion and Emission Control</b>	L	T	P	C
PRACTICUM		2	0	2	3

**Pre-requisites:**

Nil

**CO/PO Mapping**

CO / PO	P01	P02	P03	P04	P05	P06	P07
<b>C01</b>	3	3	1	3	1	1	3
<b>C02</b>	3	2	1	2	1	1	1
<b>C03</b>	3	2	1	3	1	1	2
<b>C04</b>	3	1	1	1	1	1	1
<b>C05</b>	3	3	1	1	1	1	2

Legend: 3-High Correlation, 2-Medium Correlation, 1-Low Correlation

**Instructional Strategy:**

1. Hands-on Demonstration: Conduct hands-on demonstrations to illustrate key concepts such as combustion reactions, emission formation, and the operation of emission control devices. This can help students visualize abstract concepts and make connections between theory and practice.
2. Group activities and Projects: Assign group projects where students can collaborate to research and present on specific topics related to fuels, combustion, or emission control. This encourages teamwork, communication skills, and allows students to learn from each other.
3. Assessment and feedback: Provide regular feedback to students through formative assessments, quizzes, and assignments. Encourage self-assessment and reflection to help students monitor their progress and identify areas for improvement.



1021234230	<b>Fuels, Combustion and Emission Control</b>	L	T	P	C
PRACTICUM		2	0	2	3

**Assessment Methodology:**

	<b>Continuous Assessment (40 marks)</b>				<b>End Semester Examination (60 marks)</b>
	<b>CA1</b>	<b>CA2</b>	<b>CA3</b>	<b>CA4</b>	
<b>Mode</b>	Written Test Theory (Any Two Units)	Written Test Theory (Another Two Units)	Practical Test (All Exercises)	Written Test (Complete Theory Portions)	Written Examination (Complete Theory Portions)
<b>Duration</b>	2	2	3	3 Hours	3 Hours
<b>Exam Marks</b>	50	50	100	100	100
<b>Converted to</b>	10	10	15	15	60
<b>Marks</b>	10		15	15	60
<b>Tentative Schedule</b>	6th Week	12th Week	15th Week	16th Week	

Note:

- CA1 and CA2:** Assessment written test should be conducted for 50 Marks. The marks scored will be converted to 10 Marks for each test. The best of one will be considered for the internal assessment of 10 Marks.

CA1 and CA2, Assessment written test should be conducted for two units as below.  
 Answer any Five questions. (5 X 10 Marks = 50 Marks).  
 Eight questions will be asked, students should write Five questions.  
 In each unit, Four questions can be asked. Each question may have subdivisions. A maximum of two subdivisions shall be permitted.
- CA 3:** All the exercises/experiments should be completed and kept for the practical test. The students shall be permitted to select any one by lot for the test. The practical test should be conducted as per the scheme of evaluation as below. The marks awarded will be converted to 15 Marks for the internal mark.



1021234230	<b>Fuels, Combustion and Emission Control</b>	L	T	P	C
PRACTICUM		2	0	2	3

Practical documents should be maintained for every exercise/experiment immediately after completion of the practice. The practical document should be submitted for the practical test. Each exercise/experiment should be evaluated for 10 Marks. The total marks awarded should be converted to 30 Marks for the practical test as per the scheme of evaluation as below.

**The details of the practical documents are to be prepared as per the instructions below.**

Each exercise / experiment procedure, observation and calculations should be completed on the day of practice. The same shall be evaluated for 10 marks on the day or the next day of practice before the commencement of the next exercise.

This documentation can be carried out in a separate notebook or a printed manual or a file with documents. The observation, reading, calculations, report, graphs and results should be written by the student manually in the practical documents.

The evaluated practical document should be submitted for the Practical Test (CA3). The marks scored by the students should be converted to 30 marks. The same should be included as per the allocation in the practical test.

The detailed dates of the practices and its evaluations should be maintained in the course logbook. The log book and the practical documents should be submitted for the verification by the Flying Squad and DOTE Official.

#### **SCHEME OF EVALUATION - Practical Test**

Sl.No.	Description	Marks
A	Aim & Apparatus required	10
B	Procedure / Observation	15
C	Formula / Calculation / Report	25
D	Result / Graph	10
E	Practical document (All Practicals)	30
F	Viva Voce	10
Total		100



1021234230	<b>Fuels, Combustion and Emission Control</b>	L	T	P	C
PRACTICUM		2	0	2	3

**CA4:** Model examination should be conducted for complete theory portions as per the end-semester question pattern. The marks awarded should be converted to 15 marks for the internal assessment.

**Question Pattern:**

Answer Ten questions by selecting two questions from each unit. Each question carries 10 marks each.

Four questions will be asked from every unit, students should write any two questions. The question may have two subdivisions only.

**Syllabus contents**

Unit I	FUELS AND COMBUSTION
<p><b>Theory:</b></p> <p>1.1: Fuels Classification – solid fuels – liquid fuels – gaseous fuels - merits and demerits – requirement of good fuel – calorific value of fuels – Higher calorific value – lower calorific value – Construction and working of bomb calorimeter and gas calorimeter.</p> <p>1.2: Combustion - Elements and compounds – atoms and molecules – atomic weight – molecular weight – combustion of solid fuels – combustion of gaseous fuels – theoretical weight of air required for complete combustion - theoretical volume of air required for complete combustion – Gravimetric analysis – Volumetric analysis – Weight of carbon in flue gases – weight of flue gases per kg of fuel burnt – Excess air supplied – weight of excess air supplied - simple problems.</p>	6



1021234230	<b>Fuels, Combustion and Emission Control</b>	L	T	P	C
PRACTICUM		2	0	2	3

<b>Unit II</b>	<b>ENERGY AND ALTERNATE FUELS</b>	
<b>Theory:</b>		6
<p>2.1: Fuels for IC Engines: Introduction – Desirable properties - Classification – Description the processing of crude oil – Fuels for SI Engines – octane number – octane rating - Fuels for CI Engines – cetane number – cetane rating.</p> <p>2.2: Alternate Fuels: Introduction – list of alternate fuels - Need for alternate fuel – Availability of alternate fuels. Aircraft fuels – Liquefied Petroleum Gas (LPG): Schematic diagram of LPG engine – advantages and disadvantages. Compressed Natural Gas (CNG): Schematic diagram of CNG engine – emissions - advantages and disadvantages. Ethanol: production process – emissions - advantages and disadvantages. Methanol: production process – emissions - advantages and disadvantages. Alcohol (Diesel Blends) – Dimethyl ether – Bio diesel.</p>		
<b>Unit III</b>	<b>COMBUSTION IN SI ENGINES, CI ENGINES AND AIR POLLUTION</b>	
<b>Theory:</b>		6
<p>3.1: Combustion in SI engines: Ignition limit – combustion stages – factors affecting SI combustion – Detonation and its effects – methods to control detonation - requirement of combustion chamber – types – emission of SI engines.</p> <p>3.2: Combustion in CI engines: Combustion stages – factors affecting delay period – knocking of CI engines – methods to control knocking - requirement of combustion chamber – types – emissions of CI engines – particulate matter emissions.</p> <p>3.3: Air Pollution: Introduction - Need - pollutants – sources of pollutants. Exhaust gas analysis: Orsat apparatus – construction and working principle. Smoke meter – exhaust gas analyser – Working principle. Control of smoke emissions from IC engines.</p>		



1021234230	<b>Fuels, Combustion and Emission Control</b>	L	T	P	C
PRACTICUM		2	0	2	3

<b>Unit IV</b>	<b>FILTERS AND MANIFOLDS FOR IC ENGINES, ENGINE NOISE AND EXHAUST CONTROL</b>				
<b>Theory:</b>	<p>4.1: Filters and manifolds for IC Engines Air filters – maintenance of air filter – cleaning of air filters. Engine fuel filter – types – maintenance. Engine oil filter – uses. Manifolds: Introduction – intake manifold - factors involved in design. Exhaust manifold – maintenance.</p> <p>4.2: Engine Noise Engine noise sources - Engine noise reduction – exhaust muffler – description – types – Engine silencers – selection of silencer.</p> <p>4.3: Exhaust control Construction and working principles of Catalytic converter, Diesel particulate filter, Exhaust Gas Recirculation, Lean burn engine and Oxygen Sensor (Lambda Sensor). Crankcase emission control – evaporative emission control systems.</p>				6
<b>Unit V</b>	<b>POLLUTION AND EMISSION CONTROL STANDARDS AND ACT.</b>				
<b>Theory:</b>	<p>The Air Prevention and control of Pollution Act 1981 – introduction – functions of central boards – functions of state board – power of the board - prevention and control of air pollution - penalties and procedure. Emission standards - Indian standards of emission for petrol and diesel engines – Bharat Stage emission standards – BS IV, BS VI. Impact of shifting to BS VI. Euro standards – EURO 4, EURO 5 and EURO 6. Japan emission standards. Fuel quality standards. Microprocessor-based control system – computer controls in automobiles. Pollution controlled vehicles.</p>				6
<b>Practical:</b>	<p><b>Exercise 1:</b> Determine the flash and fire point of the lubricating oil by using Open cup apparatus and Closed cup apparatus and compare the value for the given sample.</p> <p><b>Exercise 2:</b> Find the Calorific Value of diesel using Bomb calorimeter.</p>				20



1021234230	<b>Fuels, Combustion and Emission Control</b>	L	T	P	C
PRACTICUM		2	0	2	3

<p><b>Exercise 3:</b> Analysis of exhaust gases from engine by Orsat apparatus.</p> <p><b>Exercise 4:</b> Find the intensity of smoke from a diesel engine using a smoke meter.</p> <p><b>Exercise 5:</b> Measure the emissions in exhaust of an engine by exhaust gas analyser.</p> <p><b>Exercise 6:</b> Conduct speed performance tests of a single-cylinder petrol engine or diesel engine and draw the curve. 1. BHP, IHP, FHP Vs Speed 2. Volumetric efficiency, SFC Vs Speed.</p> <p><b>Exercise 7:</b> Find the Indicated horsepower of a multi-cylinder engine by the Morse test.</p> <p><b>Exercise 8:</b> Prepare the heat balance sheet on a single-cylinder petrol/diesel engine.</p>		
	Revision + Test	10
	TOTAL HOURS	60

**Suggested List of Students Activity:**

- To study high-pressure boilers and their accessories and mountings.
- Energy estimation in Global and India.
- Fuel properties investigation.
- Combustion reaction demonstration.
- Emission measurement project.
- Case studies on environment impact.
- Renewable energy debate.
- Fuel efficiency competition.

**Text book for Reference:**

1. Automobile Technology, R.B.Gupta, Satya Prakashan, New Delhi.
2. Internal Combustion Engine Fundamentals, Heywood J B, McGraw Hill Book Co.
3. The properties and performance of modern alternate fuels – SAE Paper No.841210.
4. Internal Combustion Engines, "Ganesan.V", Tata-McGraw Hill Publishing Co.



1021234230	<b>Fuels, Combustion and Emission Control</b>	L	T	P	C
PRACTICUM		2	0	2	3

5. SAE transactions, "vehicle emission ", 1982 (3 volumes).
6. The Air prevention and control of pollution Act, 1981
7. Bharat Stage Emission Standards ( BS Norms)
8. Japan Emission Norms

**Web-based/Online Resources:**

1. <https://www.youtube.com/watch?v=Fyq4Q5yWDDU&list=PLyqSpQzTE6M927gXIZdVbbsyj9cmxam-b>
2. <https://www.youtube.com/watch?v=V83pl7WbSpM>
3. <https://www.youtube.com/watch?v=BTvqfWhE-4c>

**END SEMESTER QUESTION PATTERN - Theory Exam**

**Duration: 3 Hrs.**

**Max. Marks: 100**

**Note:** Answer Ten questions by selecting two questions from each unit. Each question carries 10 marks each.

**Instruction to the Question Setters**

Four questions will be asked from every unit, students should write any two questions for 10 marks. The question may have two subdivisions only.



1021234230	<b>Fuels, Combustion and Emission Control</b>	L	T	P	C
PRACTICUM		2	0	2	3

**Equipment / Facilities required to conduct the Practical Course.**

Sl. No.	Machinery's / Equipment	Quantity
1	Open cup apparatus and Closed cup apparatus	01
2	Single cylinder petrol or diesel engine with following arrangement 1. Load test arrangement 2. Heat balance test arrangement	01
3	Multi-cylinder petrol / diesel engine with Morse test arrangement	01
4	Orsat apparatus	01
5	Smoke meter	01
6	Exhaust gas analyser	01
7	Bomb calorimeter with all accessories	01
8	Consumables	Sufficient Quantity
9	Measuring Instruments	Sufficient Quantity
10	Safety devices (PPE kit, Fire Protecting Equipment etc.)	Sufficient Quantity



1021234340	<b>Manufacturing Technology II</b>	L	T	P	C
PRACTICUM		1	0	4	3

**Introduction:**

Manufacturing, the major and the most important aspect in industries, needs utmost care and attention. Knowledge about casting processes and allied areas will be of great use to the personnel involved in production.

The areas like Patterns, Arc Welding, Gas Welding, Centre Lathe, Semi-Automatic Lathes, Automatic Lathes, Milling Machines , Abrasive Process , CNC Machines and NC Programming will provide the students an opportunity to train themselves with the skills needed for the present day industrial scenario.

**Course Objectives:**

The objective of this course is to enable the student to,

- Acquire Knowledge about types of Arc Welding, and Gas Welding.
- Knowledge about Centre Lathe, Semi-Automatic lathes and Automatic lathes
- Acquire knowledge about Milling Machines.
- Appreciate the use of Abrasive Process.
- Understand the CNC Machines and NC Machines.

**Course Outcomes:**

After successful completion of this course, the students can able to

- CO1: Acquire Knowledge about the types of Arc Welding, and Gas Welding.
- CO2: Knowledge about various Lathe, Semi-Automatic lathes and Automatic lathes.
- CO3: Understand the Milling Machines.
- CO4: Appreciate the use of Abrasive Process.
- CO5: Understand the CNC Machines and NC Machines.

**Prerequisites:**

NIL

**CO/PO Mapping:**



1021234340	<b>Manufacturing Technology II</b>	L	T	P	C
PRACTICUM		1	0	4	3

CO/PO	P01	P02	P03	P04	P05	P06	P07
<b>C01</b>	3	2	2	2	1		
<b>C02</b>	2	1	2	2	1		
<b>C03</b>	2	3	3	1	1		
<b>C04</b>	2	3	3	2	1		
<b>C05</b>	3	2	2	1	1		

Legend: 3-High Correlation, 2-Medium Correlation, 1-Low Correlation

### Instructional Strategy

- It is advised that teachers take steps to pique pupils' attention and boost their learning confidence.
- To help students learn and appreciate numerous concepts and principles in each area, teachers should provide examples from daily life, realistic situations and real-world engineering and technological applications.
- The demonstration can make the subject exciting and foster in the students a scientific mindset. Student activities should be planned on all the topics.
- Throughout the course, a theory-demonstrate-practice-activity strategy may be used to ensure that learning is an outcome and employability-based.
- All demonstrations/Hands-on practices are under a simulated environment (may be followed by a real environment as far as possible).



1021234340	<b>Manufacturing Technology II</b>	L	T	P	C
PRACTICUM		1	0	4	3

**Assessment Methodology:**

	Continuous Assessment (40 marks)				End Semester Examination (60 marks)
	CA1	CA2	CA3	CA4	
<b>Mode</b>	Practical Test	Practical Test	Written Test Theory	Practical Test	Practical Examination
<b>Portion</b>	Cycle I Exercises	Cycle II Exercises	All Units	All Exercises	All Exercises
<b>Duration</b>	2 Periods	2 Periods	3 Hours	3 Hours	3 hours
<b>Exam Marks</b>	60	60	100	100	100
<b>Converted to Marks</b>	10	10	15	15	60
<b>Marks</b>	10		15	15	60
<b>Tentative Schedule</b>	7th Week	14th Week	15th Week	16th Week	

Note:

**CA1 and CA2:** All the exercises/experiments should be completed as per the portions above and kept for the practical test. The students shall be permitted to select any one by lot for the test. The practical test should be conducted as per the scheme of evaluation as below. The marks awarded shall be converted to 10 Marks for each assessment test. Best of one will be considered for the internal assessment of 10 Marks.

Practical documents should be maintained for every exercise/experiment immediately after completion of the practice. The practical document should be submitted for the practical test. The same should be evaluated for 10 Marks for each exercise/experiment. The total marks awarded should be converted to 10 Marks for the practical test as per the scheme of evaluation as below.



1021234340	<b>Manufacturing Technology II</b>	L	T	P	C
PRACTICUM		1	0	4	3

**The details of the practical documents are to be prepared as per the instructions below.**

Each exercise / experiment procedure, observation and calculations should be completed on the day of practice. The same shall be evaluated for 10 marks on the day or the next day of practice before the commencement of the next exercise.

This documentation can be carried out in a separate notebook or a printed manual or a file with documents. The observation, reading, calculations, report, graphs and results should be written by the student manually in the practical documents.

The evaluated practical document should be submitted for the Practical Test (CA3). The marks scored by the students should be converted to 10 marks. The same should be included as per the allocation in the practical test.

The detailed dates of the practices and its evaluations should be maintained in the course logbook. The log book and the practical documents should be submitted for the verification by the Flying Squad and DOTE Official.

#### SCHEME OF EVALUATION

PART	DESCRIPTION	MARKS
A	Aim & Tools required	10
B	Preparation / Procedure	20
C	Dimensions	20
TOTAL		50
D	Practical Documents (As per the portions)	10
		60

**Cycle I:** 1, 2, 3, 4 and 5.

**Cycle II:** 6, 7, 8, 9 and 10.



1021234340	<b>Manufacturing Technology II</b>	L	T	P	C
PRACTICUM		1	0	4	3

**CA 3:** Written Test for complete theory portions should be conducted for 100 Marks as per the question pattern below. The marks scored will be converted to 15 Marks for internal assessment.

#### Question pattern – Written Test Theory

Description		Marks	
Part – A	30 MCQ from the complete theory portions	30 X 1 Mark	30 Marks
Part – B	Seven Questions to be answered out of 10 Questions.	7 X 10 Marks	70 Marks
TOTAL			100 Marks

**CA 4:** All the exercises/experiments should be completed and kept for the practical test. The students shall be permitted to select any one by lot for the test. The practical test should be conducted as per the scheme of evaluation below. After completion of all the exercises, the practical test should be conducted as per the End Semester Examination question pattern scheme of evaluation. The marks awarded should be converted to 15 Marks for the internal assessment.

#### SCHEME OF EVALUATION

##### Model Practical Examination and End Semester Examination - Practical Exam

PART	DESCRIPTION	MARKS
A	Aim & Tools required	10
B	Preparation / Procedure	20
C	Dimensions	20
D	Finish / Output	10
E	Written test (Theory Portions only)	30
F	Viva Voce	10
TOTAL		100

**Note:** For the written test 30 MCQ shall be asked from the theory portions.



1021234340	<b>Manufacturing Technology II</b>	L	T	P	C
PRACTICUM		1	0	4	3

### Syllabus Contents - Theory Portions

<b>Unit I</b>	<b>PATTERNS , ARC WELDING AND GAS WELDING</b>			
<b>Arc Welding:</b> Definition – arc welding equipment – arc welding methods – carbon arc, metal arc, Metal Inert gas (MIG), Tungsten inert gas (TIG), Atomic hydrogen, Plasma arc, Submerged arc and Electro slag welding.				3
<b>Gas welding:</b> Definition Gas Welding Equipment – Oxy and acetylene welding - Three types of flame – resistance welding – classification of resistance welding.				
<b>Unit II</b>	<b>SEMI-AUTOMATIC AND AUTOMATIC LATHES</b>			
<b>Semi-Automatic Lathes</b> Types of semi-automatic lathes – capstan and turret lathes – difference between turret and capstan.				3
<b>Automatic Lathes</b> Automatic lathe – Construction and working principle of single spindle automatic lathe–automatic screw cutting machines–multi spindle automatic lathes.				
<b>Unit III</b>	<b>MILLING MACHINES</b>			
<b>Milling machines:</b> Types–column and knee type, plain, vertical and universal milling machines – Principles of operation – specification of milling machines – work holding devices – tool holding devices Milling operations.				3
<b>Unit IV</b>	<b>ABRASIVE PROCESS</b>			
<b>Abrasive process</b> Types and classification–specifications–rough grinding–pedestal grinders -portable grinders–belt grinders. Precision grinding– cylindrical grinder–centre less grinders–surface grinder–tool and cutter grinder – principles of operations.				3



1021234340	<b>Manufacturing Technology II</b>	L	T	P	C
PRACTICUM		1	0	4	3

<b>Unit V</b>	<b>CNC MACHINES</b>			
<b>CNC machines</b>	Numerical control–definition–working principle of a CNC system– features of CNC machines–advantages of CNC machines–difference between NC and CNC–construction and working principle of turning centre–construction and working principle of machining centre.			3

**Practical Portions - Introduction.**

**10 periods**

**Centre Lathe:** Centre lathe: specifications – simple sketch - Working principle operations - Cutting speed – feed - depth of cut.

**Milling machines:** Milling cutters - Milling operations - types - straddle milling - gang milling. Indexing - Indexing plate – Indexing methods - simple indexing, differential indexing. Generating Process: gear shaper - gear hobbing - principle of operation only.

**NC Programming:** Introduction– Cartesian coordinate system–Polar coordinate system– Absolute and incremental positioning–Purpose of G and M codes. Basic Codes - basic CNC program.CNC turning program using linear interpolation and circular interpolation.

**Practical Exercises**

**40 Periods**

**Exercise No: 1.** Perform Arc welding to make a Butt Joint with the given Mild Steel. (Raw Material: 25 mm x 6 mm MS flat – 2 Nos.)

**Exercise No: 2.** Perform Gas welding to make a Lap Joint with the given sheet. (Raw Material: 16G MS sheet – 2 Nos.)



1021234340	<b>Manufacturing Technology II</b>	L	T	P	C
PRACTICUM		1	0	4	3

**Exercise No: 3.** Make the model as per the given sketch by Step turning and Taper turning operations in a Lathe. (RawMaterial:  $\varnothing 32$ mm M.S rod)

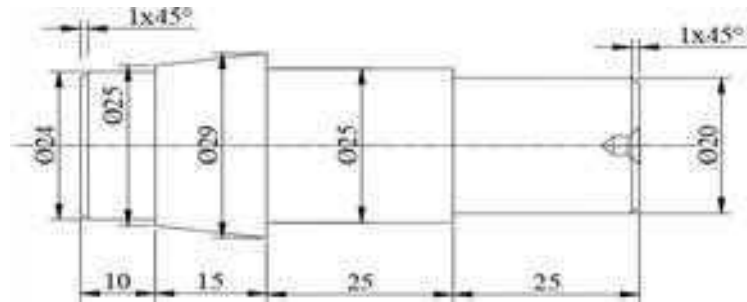

**Exercise No: 4.** Make the model as per the given sketch by Knurling and BSW Thread cutting operations in a Lathe. (Raw Material:  $\varnothing 32$  mm M.S rod)

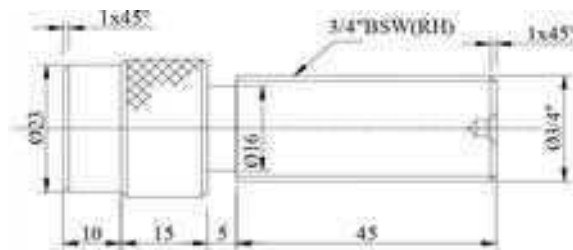

**Exercise No: 5.** Make a spur gear by differential indexing method as per the Figure using Milling Machine.

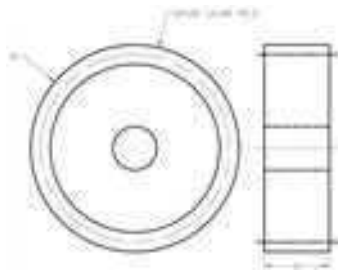

1021234340	<b>Manufacturing Technology II</b>	L	T	P	C
PRACTICUM		1	0	4	3

**Exercise No: 6.** Make a Helical gear by differential indexing method as per the Figure using Milling Machine.

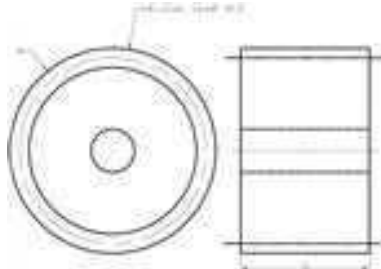

**Exercise No: 7.** Make a progressive type plug gauge as per the Figure using Cylindrical Grinding Machine

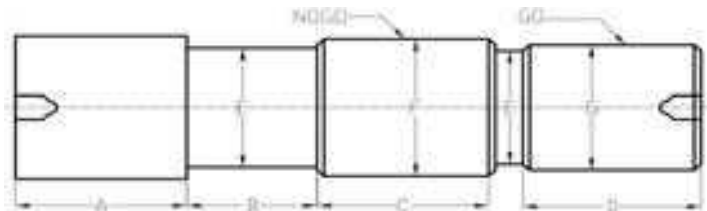

**Exercise No: 8.** Make a turning tool as per Figure using Tool and Cutter Grinder

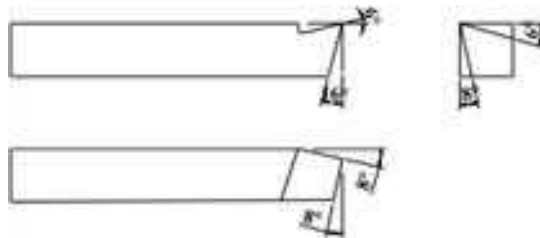

**Exercise No: 9.** Make the component in the CNC Turning Centre.

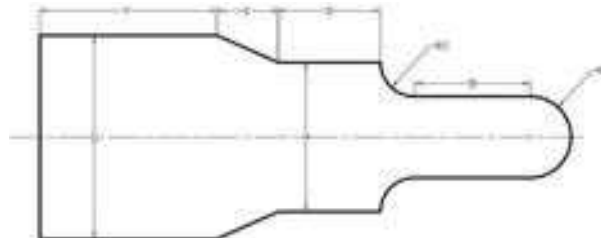

1021234340	<b>Manufacturing Technology II</b>	L	T	P	C
PRACTICUM		1	0	4	3

**Exercise No: 10.** Make the component in the CNC Milling Centre.

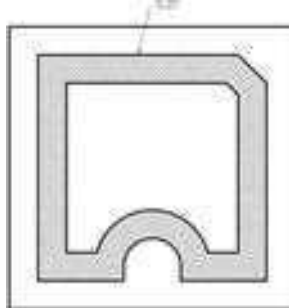

**Assessment Test + Revision**

**10 Periods**

**Suggested List of Students Activity:**

- Practice Butt joint welding using TIG/MIG welding.
- Practice Spot welding lap joint.
- Practice soldering and brazing.

**Text book for Reference:**

1. Elements of workshop Technology Volume I & II – Hajra Chowdry & Bhattacharaya - II<sup>th</sup> Edition - Media Promoters & Publishers Pvt. Ltd.
2. Introduction of basic manufacturing processes and workshop technology – Rajendersingh – New age International (P) Ltd. Publishers
3. Production Technology - P.C.SHARMA - Edn. X- S.Chand & Co.Ltd.
4. Production Technology – HMT-Edn.18-published by Tata Mc Graw Hill Publishing Co. Ltd

**Web-based/Online Resources:**

- <https://nptel.ac.in/courses/112/107/112107219/>
- <https://nptel.ac.in/courses/112/107/112107144/>
- <https://nptel.ac.in/courses/112/105/112105127/>



**DIRECTORATE OF TECHNICAL EDUCATION, CHENNAI – 600 025  
REGULATION 2023**

DAE

90

1021234340	<b>Manufacturing Technology II</b>	L	T	P	C
PRACTICUM		1	0	4	3

### END SEMESTER EXAMINATIONS – PRACTICAL EXAM

**Note:**

All the exercises / experiments should be completed before the Board Practical Examinations. End Semester Practical examination should be conducted for all the exercises / experiments for 100 Marks. Students will be permitted to select any one exercise by lot or question paper supplied by the DOTE Exam section shall be used.

The Practical Documents by the student should be submitted with a Bonafide Certificate.

### DETAILED ALLOCATION OF MARKS.

PART	DESCRIPTION	MARKS
A	Aim & Tools required	10
B	Preparation / Procedure	20
C	Dimensions	20
D	Finish / Output	10
E	Written test (Theory Portions only)	30
F	Viva Voce	10
TOTAL		100

**Note:** For the written test 30 MCQ shall be asked from the theory portions.



1021234340	<b>Manufacturing Technology II</b>	L	T	P	C
PRACTICUM		1	0	4	3

**LIST OF EQUIPMENT / TOOLS/ MACHINERY'S REQUIRED**

Sl. No.	Machines / Tools / Equipments	Quantity
1	Arc welding unit	1 No
2	Gas welding unit	1 No.
3	Lathe	4 Nos.
4	Milling Machine	2 Nos.
5	Cylindrical grinding machine or attachment	1 No.
6	Tool and Cutter Grinder	1 No.
7	CNC Turning machine	1 No.
8	CNC Milling machine	1 No.
9	Patterns and Tools	Sufficient quantity
10	Tools and Measuring instruments	Sufficient quantity
11	Personal protective equipment	Sufficient quantity
12	Fire safety equipment	Sufficient quantity
13	Consumable	Sufficient quantity



1020234440	<b>SENSORS AND ACTUATORS</b>	L	T	P	C
PRACTICUM		1	0	4	3

**Introduction:**

Sensors are needed to measure (sense) unknown signals and parameters of an engineering system and its environment. Essentially, sensors are needed to monitor and learn about the system. Sensor is a device that when exposed to a physical phenomenon (temperature, displacement, force, etc.) produces a proportional output signal (electrical, mechanical, magnetic, etc.). Actuators are needed to drive a plant. A diploma holder when employed in automated industrial process controls will be required to know the basics of Sensors and Actuators.

**Course Objectives:**

The objective of this course is to enable the student to

- Explain the types and working of various types of sensors.
- Practice with temperature sensor, proximity sensor, LVDT and Light Sensors.
- Describe the functions of Linear and Rotary Electrical actuators.
- Describe the functions of Electrical, Pneumatic and Hydraulic actuators.
- Practice with interfacing of Arduino compatible sensors and actuator with Arduino.

**Course Outcomes:**

On successful completion of this course, the student will be able to

- CO1: Describe the working of Resistive, Inductive, Temperature and Light Sensors.
- CO2: Interface and observe the behaviour of Proximity sensors with relay and buzzer.
- CO3: Construct the circuit and observe the behaviour of the solid state electronic actuator.
- CO4: Describe the working of Electrical, Pneumatic and Hydraulic actuators.
- CO5: Demonstrate the applications of Arduino compatible sensors and actuators.

**Pre-requisites:**

Applied Physics, Basic Electrical and Mechanical Engineering.



1020234440	<b>SENSORS AND ACTUATORS</b>	L	T	P	C
PRACTICUM		1	0	4	3

**CO/PO Mapping**

CO / PO	P01	P02	P03	P04	P05	P06	P07
<b>C01</b>	3	1	2	2			
<b>C02</b>	3	1	2	2			
<b>C03</b>	3	1	2	2			
<b>C04</b>	3	1	2	2			
<b>C05</b>	3	1	2	2			

*Legend: 3-High Correlation, 2-Medium Correlation, 1-Low Correlation*

**Instructional Strategy:**

- It is advised that teachers take steps to pique pupils' attention and boost their curiosity to learn.
- Implement task-based learning activities where students work on specific tasks or projects.
- Incorporate technology tools and resources, such as online platforms, interactive multimedia, and virtual communication tools, to enhance engagement and provide additional practice opportunities.
- Incorporate formative and summative assessments to gauge student progress and provide targeted feedback.
- Throughout the course, a theory-demonstrate-practice-activity strategy may be used to ensure that learning is outcome and employability based.
- All demonstrations/Hand-on practices may be followed in the real environment as far as possible.



1020234440	<b>SENSORS AND ACTUATORS</b>	L	T	P	C
PRACTICUM		1	0	4	3

**Assessment Methodology:**

	Continuous Assessment (40 marks)				End Semester Examination (60 marks)
	CA1	CA2	CA3	CA4	
<b>Mode</b>	Practical Test	Practical Test	Written Test Theory	Practical Test	Practical Examination
<b>Portion</b>	Cycle I Experiments	Cycle II Experiments	All Units	All Experiments	All Experiments
<b>Duration</b>	2 Periods	2 Periods	3 Hours	3 Hours	3 hours
<b>Exam Marks</b>	60	60	100	100	100
<b>Converted to Marks</b>	10	10	15	15	60
<b>Marks</b>	10		15	15	60
<b>Tentative Schedule</b>	7th Week	14th Week	15th Week	16th Week	

Note:

- **CA1 and CA2:** All the exercises/experiments should be completed as per the portions above and kept for the practical test. The students shall be permitted to select any one by lot for the test. The practical test should be conducted as per the scheme of evaluation as below. The marks awarded shall be converted to 10 Marks for each assessment test. Best of one will be considered for the internal assessment of 10 Marks.

Practical documents should be maintained for every experiment immediately after completion of the practice. The practical document should be submitted for the practical test. The same should be evaluated for 10 Marks for each exercise/experiment. The total marks awarded should be converted to 10 Marks for the practical test as per the scheme of evaluation as below.



1020234440	<b>SENSORS AND ACTUATORS</b>	L	T	P	C
PRACTICUM		1	0	4	3

**The details of the documents to be prepared as per the instruction below.**

Each experiment should be completed on the day of practice. The same shall be evaluated for 10 marks on the day or next day of practice before commencement of the next experiment.

This documentation can be carried out in a separate notebook or a printed manual or a file with documents. The student should draw the Circuit Diagram and take readings, do calculations and prepare the Graph/Result manually in the documents.

The detailed date of the practices and its evaluations should be maintained in the course logbook. The log book and the practical documents should be submitted for the verification by the Flying Squad and DOTE Official.

#### SCHEME OF EVALUATION

PART	DESCRIPTION	MARKS
<b>A</b>	Aim & Apparatus Required	5
<b>B</b>	Circuit Diagram	20
<b>C</b>	Connections and Execution	25
TOTAL		50
<b>D</b>	Practical Documents (As per the portions)	10
Total Marks		60

**Cycle I: 1, 2, 3, 4 and 5.**

**Cycle II: 6, 7, 8, 9 and 10.**

- **CA 3:** Written Test for complete theory portions should be conducted for 100 Marks as per the question pattern below. The marks scored will be converted to 15 Marks for internal assessment.



1020234440	<b>SENSORS AND ACTUATORS</b>	L	T	P	C
PRACTICUM		1	0	4	3

**Question pattern – Written Test Theory**

Description		Marks	
Part – A	30 MCQ Questions.	30 X 1 Mark	30 Marks
Part – B	7 Questions to be answered out of 10 Questions.	7 X 10 Marks	70 Marks
TOTAL			100 Marks

- **CA 4:** All the exercises/experiments should be completed and kept for the practical test. The students shall be permitted to select any one by lot for the test. The practical test should be conducted as per the scheme of evaluation below. After completion of all the exercises the practical test should be conducted as per End Semester Examination question pattern scheme of evaluation. The marks awarded should be converted to 15 Marks for the internal assessment.

**SCHEME OF EVALUATION**

**Model Practical Examination and End Semester Examination - Practical Exam**

PART	DESCRIPTION	MARKS
<b>A</b>	Aim & Apparatus Required	5
<b>B</b>	Circuit Diagram	20
<b>C</b>	Connections and Execution	25
<b>D</b>	Output / Result	10
<b>E</b>	Written Test (Theory Portions)	30
<b>F</b>	Viva Voce	10
TOTAL		100

Note: For the written test 30 MCQ shall be asked from the theory portions.



1020234440	<b>SENSORS AND ACTUATORS</b>	L	T	P	C
PRACTICUM		1	0	4	3

### Syllabus Contents

Theory Portion		Period
<b>UNIT I: SENSORS</b>		<b>8</b>
<p>Resistance, Inductance and Capacitive Sensors: Definition – Classification of Sensors/Transducers - Elements of measurement system – Primary Sensing Elements (Bellows, Bourdon Tube) - Potentiometer - Linear potentiometer – Rotary potentiometer - Load Cell – Strain Gauge Load Cell - Linear Variable Differential Transformer (LVDT) – Rotary - Variable Differential Transformer (RVDT) – DC Tachogenerator – AC Tachogenerator - Principles of Capacitive Sensors – Hall effect sensor.</p> <p>Temperature Sensors: Thermocouple – Resistance Temperature Detector – Thermistor - Infrared (IR) thermometer.</p> <p>Proximity Sensors: Inductive Proximity Sensor – Capacitive Proximity Sensor - Photoelectric Proximity Sensor - Ultrasonic Proximity Sensor - Basic Reed Switch.</p> <p>Light Sensor: Photodiode – Phototransistor – Photoconductive Cell - Photovoltaic Cells - Bar Code Reader - Shaft Encoders - Encoder Types (Incremental Encoder, Absolute Encoder) - Optical Shaft Encoder - Photoelectric Tachometer.</p> <p>Arduino Compatible Sensor : Voltage Sensor – Current Sensor – LM35 Sensor - Ultrasonic Sensor - Force Sensor – Moisture Sensor – Gas Sensor.</p>		
<b>Practical Exercises:</b>		
Ex.No	Name of the Experiment	Period
1.	TEMPERATURE MEASUREMENT <u>Activities to Perform:</u> i) Construct a circuit to measure Temperature of Liquid using Thermistor or Thermocouple or RTD. ii) Also find the graphical relationship between input and output.	<b>4</b>



1020234440	<b>SENSORS AND ACTUATORS</b>	L	T	P	C
PRACTICUM		1	0	4	3

2.	<b>BEHAVIOUR OF PROXIMITY SENSORS</b> <u>Activities to Perform:</u> i) Observe the behaviour of Inductive proximity sensor and Capacitive Proximity sensor for different material samples. ii) Interface relay and buzzer with sensors to test the output.	<b>4</b>
3.	<b>LVDT</b> <u>Activities to Perform:</u> i) Construct a circuit for Measurement of Linear Displacement using LVDT. ii) Find the graphical relationship between input and output.	<b>4</b>
4.	<b>PERFORMANCE OF LIGHT SENSOR</b> <u>Activities to Perform:</u> i) Construct a circuit to obtain the VI characteristics and Response Characteristics of Photoconductive Cell (LDR). ii) Construct a circuit to measure the speed of the motor using Optical Sensor.	<b>4</b>
5.	<b>PERFORMANCE OF ULTRASONIC AND MOISTURE SENSORS</b> <u>Activities to Perform:</u> i) Interface Ultrasonic sensor with Arduino and measure the distance of the object. ii) Interface Moisture sensor with Arduino and measure the moisture content in the soil.	<b>4</b>



1020234440	<b>SENSORS AND ACTUATORS</b>	L	T	P	C
PRACTICUM		1	0	4	3

<b>UNIT II: ACTUATORS</b>		
<p>Electrical Actuators: General aspects - Switching Devices – Mechanical Switches (Push button – SPST –SPDT – Limit Switch – Solenoid – Relays) – Solid State switches (Diode, Transistor and Thyristor) – DC Motors – AC Motors – Stepper Motors – Servo Motors.</p> <p>Pneumatic Actuators: Introduction – Components of a Pneumatic Systems –Linear actuators – Construction and working of Single acting and Double acting cylinders - Rotary Actuators – Air Motors – Types of Air Motors - Piston type Motor, Vane Motor, Turbine Motor - Applications of Air Motors.</p> <p>Hydraulic Actuators: Hydraulic Power Supply - Components of Hydraulic system - Linear actuators - Construction and working of Single acting and Double acting cylinders – Applications of Hydraulic Cylinders - Some example mechanism driven by an Hydraulic cylinders - Rotary Actuators – Hydraulic Motors – Advantages and Applications of Hydraulic Motors.</p>		<b>7</b>
<b>Practical Exercises:</b>		
<b>Ex.No</b>	<b>Name of the Experiment</b>	<b>Period</b>
6.	<p>OBSERVE THE BEHAVIOUR OF TRANSISTOR AS A SWITCH</p> <p><u>Activities to Perform:</u></p> <p>i) Construct a circuit to get ON/OFF control on DC Motor using Push Button, SPST, SPDT and Limit Switch.</p> <p>ii) Construct a circuit to get ON/OFF control on DC Motor using Transistor and Relay.</p>	<b>4</b>
7.	<p>FORWARD AND REVERSE CONTROL OF AC MOTOR</p> <p><u>Activities to Perform:</u></p> <p>i) Connect Forward Reverse Control switch to change the direction of rotation of three phase induction motor.</p> <p>ii) Demonstrate the Forward and Reverse operation of Motor.</p>	<b>4</b>



1020234440	<b>SENSORS AND ACTUATORS</b>	L	T	P	C
PRACTICUM		1	0	4	3

	iii) Measure the No-Load current in each phase using Tongue tester (Clamp Meter).	
8.	<b>PNEUMATIC CIRCUIT FOR DOUBLE ACTING CYLINDER</b> <u>Activities to Perform:</u> i) Construct a Pneumatic Circuit to control double acting pneumatic cylinder using 5/2 Solenoid Valve. ii) Discuss the behaviour of cylinder as linear actuator.	<b>4</b>
9.	<b>OBSERVE THE BEHAVIOUR OF HYDRAULIC MOTOR</b> <u>Activities to Perform:</u> i) Construct a Hydraulic Circuit to control Hydraulic Motor. ii) Observe the behaviour of Hydraulic Motor.	<b>4</b>
10.	<b>SERVO MOTOR CONTROL WITH AN ARDUINO</b> <u>Activities to Perform:</u> i) Construct an Arduino based circuit to sweeps the shaft of servo motor back and forth across 180 degree. ii) Interface potentiometer with Arduino and based on its position get the control of servo motor shaft.	<b>4</b>
Revision + Test + Practice		<b>20</b>
Total		<b>75</b>

**Suggested List of Students Activity:**

1. Activity 1 : Each student writes and submits the assignment on the topic Basics of Electricity, Ohm's Law and Electromagnetism.
2. Activity 2 : Four students can be grouped as a batch and practice an additional experiment to interface any one of the Arduino compatible sensors (LM35 Temperature sensor, Force Sensor, Gas Sensor, Voltage Sensor, Humidity Sensor, Rain Sensor, Acceleration sensor, magnetic sensor, Infrared sensor etc.,) with Arduino and observe the behaviour of sensors.



1020234440	<b>SENSORS AND ACTUATORS</b>	L	T	P	C
PRACTICUM		1	0	4	3

**Text book for Reference:**

1. D. Patranabis, Sensors and Transducers, Multicolour Edition, Second Edition, PHI Learning Private Limited., 2013.
2. Er. R.K. Rajput, A Textbook of Mechatronics, Fourth Edition, S. Chand & Co., 2016.
3. Jacob Fraden, Handbook of Modern Sensors: Physics, Designs and Application, Fourth edition, Springer, 2010.
4. Massood Tabib and Azar, Microactuators Electrical, Magnetic, thermal, optical, mechanical, chemical and smart structures, First edition, Kluwer academic publishers, Springer, 1997.

**Web-based/Online Resources:**

- <https://archive.nptel.ac.in/courses/108/108/108108147/>
- <https://www.youtube.com/watch?v=H90EAn3Uc2w>
- <https://www.youtube.com/watch?v=Ab9U7NQB1kA>



1020234440	<b>SENSORS AND ACTUATORS</b>	L	T	P	C
PRACTICUM		1	0	4	3

**Equipment / Facilities required to conduct the Practical Course.**

S.No	Name of the Equipment's	Quantity Required
1.	Temperature Measurement using Thermocouple / Thermistor / RTD Kit	1 No
2.	Inductive and Capacitive Proximity Sensors, Relay, Buzzer, Suitable Power Supply Unit	Each 1 No
3.	LVDT Trainer Kit	1 No
4.	LDR, MC Ammeter and Voltmeter, 0-30V DC Power Supply Unit, DC Motor with Optical Sensor set up	Each 1 No
5.	Arduino Shield, Arduino compatible Ultrasonic Sensor and Moisture sensor	Each 1 No
6.	Push Button, SPST, SPDT, Limit Switch, Low Voltage DC Motor, Transistor and Relay	Each 1 No
7.	3 Phase Induction Motor, Forward Reverse Control switch and Clamp Meter	Each 1 No
8.	Double acting Pneumatic cylinder, Directional Control Valve, Compressor	Each 1 No
9.	Hydraulic Motor, Control Valve, Hydraulic Power Bank	Each 1 No
10.	Arduino shield, Arduino compatible Servo Motor and Potentiometer	Each 1 No
11.	Other Consumables	As Required



1020234440	<b>SENSORS AND ACTUATORS</b>	L	T	P	C
PRACTICUM		1	0	4	3

### END SEMESTER EXAMINATIONS – PRACTICAL EXAM

**Note:**

All the exercises should be completed before the Board Practical Examinations. End Semester Practical examination should be conducted for all the exercises / experiments for 100 Marks. Students will be permitted to select any one exercise by lot or question paper supplied by the DOTE Exam section shall be used. The record of work done by the student should be submitted with a Bonafide Certificate.

### SCHEME OF EVALUATION

PART	DESCRIPTION	MARKS
A	Aim & Apparatus Required	5
B	Circuit Diagram	20
C	Connections / Execution	25
D	Output / Result	10
E	Written Test	30
F	Viva Voce	10
TOTAL		100

Note: For the written test 30 MCQ shall be asked from the theory portions.



1021234540	<b>Automobile Component Design</b>	L	T	P	C
PRACTICUM		1	0	2	2

**Introduction:**

Automobile Engineering Diploma Engineer is expected to possess a thorough understanding and Modelling of automobile components which will develop in detail from block drawings and sketches. The detailed technical drawings which describe every component in a way that will enable it to be constructed and operated. This course enables the students to draw the Automobile components using 3D modelling software.

**Course Objectives:**

- To help students gain knowledge about standards on drafting and modelling.
- To understand the basics of assembly drawing preparation of automobile components.
- To appreciate the process of Modelling various components.
- Create 3D Solid models of Automobile components using modelling software
- To develop an ability to model components to meet desired needs within realistic constraints.

**Course Outcomes:**

After successful completion of this course, the students can able to

C01: Understand the Geometric construction and commands.

C02: Understand the Solid Modelling concepts and techniques.

C03: Acquire the knowledge of various standards and specifications about Automobile components.

C04: Acquire the knowledge of 3D Modelling to prepare standard dimensioned drawings of automobile components.

C05: Prepare part drawing and assembly drawings using 3D Modelling software as per industrial Standards.



1021234540	<b>Automobile Component Design</b>	L	T	P	C
PRACTICUM		1	0	2	2

**Pre-requisites:**

- Fundamental concepts and components of Automobile Engineering.
- Basic knowledge in creation of Assembly drawing with standards.

**CO/PO Mapping**

CO / PO	P01	P02	P03	P04	P05	P06	P07
<b>C01</b>	2	-	2	2	-	-	1
<b>C02</b>	1	2	2	2	-	-	1
<b>C03</b>	1	1	1	1	-	-	1
<b>C04</b>	2	-	3	3	-	-	1
<b>C05</b>	-	1	2	2	-	-	1

Legend: 3-High Correlation, 2-Medium Correlation, 1-Low Correlation



1021234540	<b>Automobile Component Design</b>	L	T	P	C
PRACTICUM		1	0	2	2

**Assessment Methodology:**

	<b>Continuous Assessment (40 marks)</b>				<b>End Semester Examination (60 marks)</b>
	<b>CA1</b>	<b>CA2</b>	<b>CA3</b>	<b>CA4</b>	
<b>Mode</b>	Practical Test	Practical Test	Written Test Theory	Practical Test	Practical Examination
<b>Portion</b>	Exercises 1 and 2.	Exercises 3 and 4	All Units	All Exercises	All Exercises
<b>Duration</b>	2 Periods	2 Periods	3 Hours	3 Hours	3 hours
<b>Exam Marks</b>	60	60	100	100	100
<b>Converted to Marks</b>	10	10	15	15	60
<b>Marks</b>	10		15	15	60
<b>Tentative Schedule</b>	7th Week	14th Week	15th Week	16th Week	

Note:

- **CA1 and CA2:** All the exercises/experiments should be completed as per the portions above and kept for the practical test. The students shall be permitted to select any one by lot for the test. The practical test should be conducted as per the scheme of evaluation as below. The marks awarded shall be converted to 10 Marks for each assessment test. Best of one will be considered for the internal assessment of 10 Marks.

Practical documents should be maintained for every exercise / experiment immediately after completion of the practice. The practical document should be submitted for the practical test. The same should be evaluated for 10 Marks for each exercise/experiment.



1021234540	<b>Automobile Component Design</b>	L	T	P	C
PRACTICUM		1	0	2	2

The total marks awarded should be converted to 10 Marks for the practical test as per the scheme of evaluation as below.

**The details of the practical documents are to be prepared as per the instructions below.**

Each exercise / experiment procedure, observation and calculations should be completed on the day of practice. The same shall be evaluated for 10 marks on the day or the next day of practice before the commencement of the next exercise.

This documentation can be carried out in a separate notebook or a printed manual or a file with documents. The observation, reading, calculations, report, graphs and results should be written by the student manually in the practical documents.

The evaluated practical document should be submitted for the Practical Test. The marks scored by the students should be converted to 10 marks. The same should be included as per the allocation in the practical test.

The detailed dates of the practices and its evaluations should be maintained in the course logbook. The log book and the practical documents should be submitted for the verification by the Flying Squad and DOTE Official.

#### SCHEME OF EVALUATION

PART	DESCRIPTION	MARKS
A	Creation - Part Modelling	25
B	Assembled Solid Modelling	25
TOTAL		50
C	Practical Documents (As per the portions)	10
		60



1021234540	<b>Automobile Component Design</b>	L	T	P	C
PRACTICUM		1	0	2	2

- **CA 3:** Written Test for complete theory portions should be conducted for 100 Marks as per the question pattern below. The marks scored will be converted to 15 Marks for internal assessment.

#### Question pattern – Written Test Theory

Description		Marks	
Part – A	30 MCQ from the complete theory portions	30 X 1 Mark	30 Marks
Part – B	Seven Questions to be answered out of 10 Questions.	7 X 10 Marks	70 Marks
TOTAL			100 Marks

- **CA 4:** All the exercises/experiments should be completed and kept for the practical test. The students shall be permitted to select any one by lot for the test. The practical test should be conducted as per the scheme of evaluation below. After completion of all the exercises, the practical test should be conducted as per the End Semester Examination question pattern scheme of evaluation. The marks awarded should be converted to 15 Marks for the internal assessment.

#### SCHEME OF EVALUATION

##### Model Practical Examination and End Semester Examination - Practical Exam

PART	DESCRIPTION	MARKS
A	Creation - Part Modelling	25
B	Assembled Solid Modelling	25
C	Printout	10
D	Written test (Theory Portions only)	30
E	Viva Voce	10
TOTAL		100

**Note:** For the written test 30 MCQ shall be asked from the theory portions



1021234540	<b>Automobile Component Design</b>	L	T	P	C
PRACTICUM		1	0	2	2

### Syllabus Contents

<b>THEORY Portions - 15 Periods</b>
<p><b>GEOMETRIC DIMENSIONING AND TOLERANCING</b></p> <p>Introduction: Geometric product definition principles; verification of position with open setup; geometric characteristic symbols</p> <p>Geometric Dimensioning and Tolerancing: an explanation of tolerance zone conversion; surfaces, features, features of size, datum features, datum features of size, and datum's; tolerances; components common to geometric dimensioning &amp; tolerances drawing; fits &amp; allowances, advantages of GD&amp;T.</p> <p>MMC, LMC &amp; RFS: Maximum Material Condition (meaning &amp; use); Least Material Condition (meaning &amp; use); Regardless of Feature Size How to read a Feature Control FrameDatum Feature of Size Representation: Modes of datum feature representation; angular orientation.</p> <p>Form Controls: flatness; straightness: circularity; free state variation; circularity.</p> <p>Orientation Controls: orientation characteristics; angularity; perpendicularity Profile; line element controls Run out: circular &amp; total Location: concentricity; the return of symmetry; position</p>



1021234540	<b>Automobile Component Design</b>	L	T	P	C
PRACTICUM		1	0	2	2

### Practical Portions

<p><b>INTRODUCTION TO SOLID MODELING:</b> Introduction to Software. File Management in a Solid Modelling Application - Creation of New Part file, saving parts, Erasing and Deleting parts.</p> <p><b>SKETCHER:</b> Concepts and understanding of Sketching Environment - Sketching fundamentals – Creation and Dimensioning a sketch: Constraining the geometry with dimensions, Modification of a sketch - Creation of proper sketches for part modeling.</p> <p><b>CREATION OF FEATURES &amp; DATUM FEATURES:</b> Extrude, Revolve – Protrusion and Cut, Holes, Rounds, Chamfer, Shell, Rib, Sweep and Blend features. Creation of Datum Features: Datum Planes and Datum Axes.</p> <p><b>Copying Features:</b> Copy, Move, Mirror, Rotate - Various methods</p> <p><b>Patterning Features:</b> Pattern types; Identical, Varying &amp; General Dimensional &amp;, Modifying Patterns.</p> <p><b>Modifying Features:</b> Edit, Redefine, Modification of sketch.</p> <p><b>CREATION OF SECTIONS:</b> Sectioning of 3D models and views</p> <p><b>VIEW FUNCTIONS &amp; COLORS:</b> Spinning the model, Panning and Zooming, Controlling model appearances and colors - Orientation of views - managing various oriented views.</p> <p><b>FILE IMPORT / EXPORT:</b> Conversion of Part models to standard formats like STL, IGES, and STEP etc to work with other modelling application softwares.</p> <p>Fusion 360 / Free CAD / Auto CAD / PTC Creo / Solid works / CATIA / Autodesk Inventor / etc..</p>	4
--	---



1021234540	<b>Automobile Component Design</b>	L	T	P	C
PRACTICUM		1	0	2	2

<b>PRACTICAL EXERCISES</b>		
<b>3D Solid Modeling Assembled Drawing</b>		
Ex.No	Name of the Exercise	Hours
1	Modelling of piston assembly	4
2	Modelling of the connecting rod assembly	4
3	Modelling of crankshaft assembly.	4
4	Modelling of cylinder block assembly (Single cylinder)	4
Practice + Continuous Test + Revision		10
<b>TOTAL HOURS</b>		<b>45</b>

**Text book for Reference:**

1. Jain. R. K, "Machine Design", Khanna Publishers, New Delhi, 2005.
2. Giri, N.K., "Automobile Mechanics", Khanna publishers, New Delhi, 2007
3. K. L. Narayana - Machine drawing, New Age International, 2009.
4. R.S. Khurmi & J. K. Guptha, "A Textbook of Machine Design", 34th edition, S. Chand publication. 2014.
5. R. K. Dhawan - A Text book on Machine Drawing, S. Chand Publishing, 2015.
6. Richard G Budynas Richard Gordon Budynas, J.Keith Nisbett., "Shigley's Mechanical Engineering Design" 10th edition, Tata McGraw-Hill, 2015.

**Web-based/Online Resources:**

- <https://www.youtube.com/watch?v=-M38FMZDF5E>
- <https://www.youtube.com/watch?v=EpemDEKCKHY>
- <https://www.youtube.com/watch?v=iycK4vp8-Ok>
- <https://www.youtube.com/watch?v=B8N2xf-ez5o>
- <https://www.youtube.com/watch?v=bs52WhdEAt0>
- <https://www.youtube.com/watch?v=-p1Hs5KBbAc>



1021234540	<b>Automobile Component Design</b>	L	T	P	C
PRACTICUM		1	0	2	2

### END SEMESTER EXAMINATIONS – PRACTICAL EXAM

**Note:**

All the exercises / experiments should be completed before the Board Practical Examinations. End Semester Practical examination should be conducted for all the exercises / experiments for 100 Marks. Students will be permitted to select any one exercise by lot or question paper supplied by the DOTE Exam section shall be used.

The Practical Documents by the student should be submitted with a Bonafide Certificate.

Part	Description	Marks
A	Creation - Part Modelling	25
B	Assembled Solid Modelling	25
C	Printout	10
D	Written test (Theory Portions only)	30
E	Viva Voce	10
<b>TOTAL MARKS</b>		<b>100</b>

**Note:** For the written test 30 MCQ shall be asked from the theory portions



1021234540	<b>Automobile Component Design</b>	L	T	P	C
PRACTICUM		1	0	2	2

#### **LIST OF EQUIPMENT**

1. Personal computer – 30 Nos.
2. Printer – 1 No.
3. Required Software's: 3D Solid Modelling software (Fusion 360 / Free CAD / AutoCAD / PTC Creo / Solidworks / CATIA / Autodesk Inventor / etc...) - Sufficient strength.



1020234640	<b>METROLOGY AND MEASUREMENTS</b>	L	T	P	C
PRACTICUM		1	0	4	3

### Introduction

The progress in metrology and measurements is highly necessary and has led to improvements in product quality, enhanced scientific research capabilities, and increased efficiency in diverse industries including manufacturing, automobile, aerospace, and quality control. It encompasses various disciplines and techniques used to ensure the accuracy, precision, and reliability of measurements. Therefore, the study of metrology and measurements is essential for maintaining uniformity and excellence across various fields, including manufacturing and scientific research.

### Course Objectives

The objective of this course is to prepare the student,

- To impart knowledge about different measuring instruments.
- To provide fundamental principles of metrology and understand the significance of accurate measurements.
- To acquire knowledge regarding the measurement of linear and angular dimensions of components and assemblies.
- To impart knowledge on advanced measurement techniques for quality control in manufacturing industries

### Course Outcomes

On successful completion of this course, the student will be able to,

- C01: Classify the measuring instruments based on their applications.
- C02: Select appropriate instrument for linear dimensions
- C03: Select appropriate instrument for angular dimensions
- C04: Explain various instruments used in measuring screw threads and gears
- C05: Discuss about the applications of CMM and LASER technology in metrology

### Pre-requisites

Knowledge of basic measuring instruments.



1020234640	<b>METROLOGY AND MEASUREMENTS</b>	L	T	P	C
PRACTICUM		1	0	4	3

### CO/PO Mapping

CO / PO	P01	P02	P03	P04	P05	P06	P07
<b>C01</b>	2			2			
<b>C02</b>	2			2			
<b>C03</b>	2			2			
<b>C04</b>	2			2			
<b>C05</b>	2			2			

**Legend:** 3-High Correlation, 2-Medium Correlation, 1-Low Correlation

### Instructional Strategy

- It is advised that teachers take steps to pique pupils' attention and boost their curiosity to learn.
- Implement task-based learning activities where students work on specific tasks or projects.
- Incorporate technology tools and resources, such as online platforms, interactive multimedia, and virtual communication tools, to enhance engagement and provide additional practice opportunities.
- Incorporate formative and summative assessments to gauge student progress and provide targeted feedback.
- Throughout the course, a theory-demonstrate-practice-activity strategy may be used to ensure that learning is outcome and employability based.
- All demonstrations/Hand-on practices may be followed in the real environment as far as possible.



1020234640	<b>METROLOGY AND MEASUREMENTS</b>	L	T	P	C
PRACTICUM		1	0	4	3

**Assessment Methodology:**

	<b>Continuous Assessment (40 marks)</b>				<b>End Semester Examination (60 marks)</b>
	<b>CA1</b>	<b>CA2</b>	<b>CA3</b>	<b>CA4</b>	
<b>Mode</b>	Practical Test	Practical Test	Written Test Theory	Practical Test	Practical Examination
<b>Portion</b>	Cycle I Exercises	Cycle II Exercises	All Units	All Exercises	All Exercises
<b>Duration</b>	2 Periods	2 Periods	3 Hours	3 Hours	3 hours
<b>Exam Marks</b>	60	60	100	100	100
<b>Converted to Marks</b>	10	10	15	15	60
<b>Marks</b>	10		15	15	60
<b>Tentative Schedule</b>	7th Week	14th Week	15th Week	16th Week	

Note:

- **CA1 and CA2:** All the exercises/experiments should be completed as per the portions above and kept for the practical test. The students shall be permitted to select any one by lot for the test. The practical test should be conducted as per the scheme of evaluation as below. The marks awarded shall be converted to 10 Marks for each assessment test. Best of one will be considered for the internal assessment of 10 Marks.

Practical documents should be maintained for every exercise / experiment immediately after completion of the practice. The practical document should be submitted for the practical test. The same should be evaluated for 10 Marks for each exercise/experiment. The total marks awarded should be converted to 10 Marks for the practical test as per the scheme of evaluation as below.



1020234640	<b>METROLOGY AND MEASUREMENTS</b>	L	T	P	C
PRACTICUM		1	0	4	3

**The details of the documents to be prepared as per the instruction below.**

Each exercise should be completed on the day of practice. The same shall be evaluated for 10 marks on the day or next day of practice before commencement of the next exercise.

This documentation can be carried out in a separate notebook or a printed manual or a file with documents. The observations, readings, calculations and sketches should be written by the student manually in the document.

The detailed date of the practices and its evaluations should be maintained in the course logbook. The log book and the practical documents should be submitted for the verification by the Flying Squad and DOTE Official.

#### SCHEME OF EVALUATION

PART	DESCRIPTION	MARKS
<b>A</b>	Procedure / Preparation	10
<b>B</b>	Observation / Dimensions	20
<b>C</b>	Accuracy	20
TOTAL		50
<b>D</b>	Practical Documents (As per the portions)	10
		60

Cycle - I            Exercise 1, 2, 3, 4, 5 and 6.

Cycle - II          Exercise 7, 8, 9 and 10.

- **CA 3:** Written Test for complete theory portions should be conducted for 100 Marks as per the question pattern below. The marks scored will be converted to 15 Marks for internal assessment.



1020234640	<b>METROLOGY AND MEASUREMENTS</b>	L	T	P	C
PRACTICUM		1	0	4	3

**Question pattern – Written Test Theory**

Description		Marks	
Part – A	30 MCQ from the complete theory portions.	30 X 1 Mark	30 Marks
Part – B	Seven Questions to be answered out of 10 Questions.	7 X 10 Marks	70 Marks
TOTAL			100 Marks

- **CA 4:** All the exercises/experiments should be completed and kept for the practical test. The students shall be permitted to select any one by lot for the test. The practical test should be conducted as per the scheme of evaluation below. After completion of all the exercises the practical test should be conducted as per End Semester Examination question pattern scheme of evaluation. The marks awarded should be converted to 15 Marks for the internal assessment.

**SCHEME OF EVALUATION**

PART	DESCRIPTION	MARKS
A	Procedure / Preparation	10
B	Observation / Dimensions	20
C	Accuracy	20
D	Result	10
E	Viva voce	10
F	Written test	30
		100

**Note:** For the written test 30 MCQ shall be asked from the theory portions.



1020234640	<b>METROLOGY AND MEASUREMENTS</b>	L	T	P	C
PRACTICUM		1	0	4	3

### Syllabus contents

<b>THEORY</b>		
<b>UNIT I: LINEAR MEASUREMENTS AND COMPARATORS</b>		<b>Periods</b>
<p><b>Basics of Metrology</b></p> <p>Scope of Metrology, basic units, important terminology, Measurement – Need, Process, Role in quality control; Factors affecting measurement - SWIPE; international standardization, the bureau of Indian standards - important elements of measurements - methods of measurements.</p> <p>Precision - accuracy - definition - factors affecting the accuracy of the measuring system - general rules for accurate measurements - precautions for use of instruments so as to avoid in accuracy in measurements - reliability – definition, Measurement uncertainty, Measurement system analysis, Compare systematic error and random error, Selection of measuring instruments - Calibration of measuring instruments.</p> <p><b>Linear Measurements</b></p> <p>Linear Measuring Instruments – Vernier caliper, Micrometer, Vernier height gauge, Depth Micrometer, bore gauge, Telescoping gauge; Gauge blocks – Use and precautions, possible sources of errors in micrometers – slip gauges - requirements – Indian standard – care and use.</p> <p><b>Comparator</b></p> <p>Comparators – Working and advantages - Types - Mechanical and Pneumatic Comparators.</p>		8
<b>Practical Exercises:</b>		
<b>Ex. No</b>	<b>Name of the Experiment</b>	<b>Hours</b>
1	VERNIER CALIPER i) Measure the dimensions of ground MS flat/Cylindrical bush using Vernier Caliper. ii) Compare the results with Digital Vernier Caliper.	5



1020234640	<b>METROLOGY AND MEASUREMENTS</b>	L	T	P	C
PRACTICUM		1	0	4	3

2	<b>OUTSIDE MICROMETER</b> i) Measure the diameter of a wire using micrometer ii) Compare the results with a digital Outside micrometer.	5
3	<b>INSIDE MICROMETER</b> i) Measure the inside diameter of the bore of a bush cylindrical component using Inside micrometer ii) Compare the results with digital inside micrometer.	5
4	<b>SLIP GAUGES</b> Measure the thickness of ground MS plates using slip gauges.	5
5	<b>VERNIER HEIGHT GAUGE</b> Measure the height of gauge blocks or parallel bars using vernier height gauge.	5
6	<b>MECHANICAL COMPARATOR</b> Find out the measurement of a given component and Compare with a standard component using a mechanical comparator and slip gauge.	5

**THEORY**

**UNIT II: ANGULAR MEASUREMENTS, CMM, SURFACE & ADVANCED METROLOGY**

<p><b>Angular Measurements:</b> Angular measuring instruments – Bevel protractor, Angle gauges, Precision level, Sine bar, Autocollimator. Opto-mechanical measurements using a measuring microscope and Profile projector. Measurement of Screw threads – Single element measurements – Pitch Diameter, Lead, Pitch. Measurement of Gears – purpose – Analytical measurement – Runout, Pitch variation, Tooth profile, Tooth thickness, Lead.</p> <p><b>Coordinating measuring Machine:</b> Basic concept of CMM – Types of CMM – Constructional features – Probes – Accessories – Software – Applications.</p> <p><b>Advanced Metrology:</b> Basic concepts of lasers - types of lasers - laser and LED based distance measuring instruments.</p>	7
---	---



1020234640	<b>METROLOGY AND MEASUREMENTS</b>	L	T	P	C
PRACTICUM		1	0	4	3

<b>Practical Exercises:</b>		
<b>Ex. No.</b>	<b>Name of the Experiment</b>	
7	UNIVERSAL BEVEL PROTRACTOR Measure the angle of a V-block/Taper Shank of Drill/ Dovetail using universal bevel protractor.	5
8	SINE BAR Measure the angle of the machined surface using sine bar with slip gauges.	5
9	SCREW THREAD MICROMETER Measure the geometrical dimensions of V-Thread using screw thread micrometer.	5
10	GEAR TOOTH VERNIER CALIPER Measure the geometrical dimensions of spur gear using gear tooth vernier caliper.	5
Activity + Revision + Assessment Test		10
Total		75

### **Suggested List of Student Activity**

1. Each student writes and submits the assignment on the topic of Methods of measurements, Precautions to avoid inaccuracy in measurements, Selection and Calibration of measuring instruments.
2. Four students can be grouped as a batch to measure the various dimensions of taper shank drill bit and spur gear and submit the activity report. The activity report should have the diagram and various dimensions of the taper shank drill bit and spur gear.
3. Visit Industry to study the working of the CMM. Prepare a report.
4. Visit Industry to study the working of the Profile Projector. Prepare a report.
5. Study the various types of Comparator. Prepare a report.



1020234640	<b>METROLOGY AND MEASUREMENTS</b>	L	T	P	C
PRACTICUM		1	0	4	3

**Text and Reference books.**

1. R. K. Jain, Engineering Metrology, 22 nd Edition, Khanna Publishers, 2022.
2. N. V. Raghavendra and L. Krishnamurthy, Engineering Metrology and Measurements, Oxford University Press India, 2013.
3. R. K. Rajput, Engineering Metrology and Instrumentation, S.K. Kataria & Sons, 2nd Edition, 2013.
4. Samir Mekid, Metrology and Instrumentation: Practical Applications for Engineering and Manufacturing, John Wiley & Sons, Inc., 2021.
5. Anand K. Bewoor & Vinay A. Kulkarni, Metrology & measurement, Tata McGraw-Hill, 2009.
6. Rega Rajendra, Principles of Engineering Metrology, Jaico Publishing House, 2008.

**Web-based/Online Resources**

- <https://archive.nptel.ac.in/courses/112/104/112104250/>

**END SEMESTER EXAMINATIONS – PRACTICAL EXAM.**

**SCHEME OF EVALUATION**

PART	DESCRIPTION	MARKS
A	Procedure / Preparation	10
B	Observation / Dimensions	20
C	Accuracy	20
D	Result	10
E	Viva voce	10
F	Written test	30
		100

**Note:** For the written test 30 MCQ shall be asked from the theory portions.



1020234640	<b>METROLOGY AND MEASUREMENTS</b>	L	T	P	C
PRACTICUM		1	0	4	3

**LIST OF EQUIPMENTS**

<b>S. No</b>	<b>Name of the Equipment</b>	<b>Quantity required</b>
1	Vernier Caliper	2 nos
2	Digital Vernier Caliper	2 nos
3	Outside Micrometer	2 nos
4	Digital Outside Micrometer	2 nos
5	Inside Micrometer	2 nos
6	Digital Inside Micrometer	2 nos
7	Slip Gauges	2 nos
8	Vernier Height Gauge	1 no
9	Surface Plate	2 nos
10	Dial Indicator (0-10)	2 nos
11	Universal Bevel Protractor	2 nos
12	Sine Bar with Slip gauges	2 nos
13	Screw Thread Micrometer	2 nos
14	Gear Tooth Vernier Caliper	1 no
15	Mechanical Comparator	1 No.
	Consumable	Sufficient Quantity



1021235130	<b>VEHICLE BODY ENGINEERING</b>	L	T	P	C
Practicum		2	0	2	3

**Introduction:**

To impart knowledge to the students about constructional details of different types of vehicle bodies and about vehicle body repair works and painting.

- Aerodynamic characteristics determine the fuel consumption of high speed and stability in cross wind. +ve pressure on the front and -ve pressure on the rear end of the car should be minimized.
- Vehicle body contributes about 40% to 60% of total weight in the case of cars and about 65 to 70% in the case of buses. Payload is determined by body weight.
- Reduction in body weight not only improves capacity but also fuel consumption.
- A direct test body contributes about 50 to 70% of the total cost. In indirect cost expected life influences the price.

**Course Objectives:**

The objective of the course is to enable the students:

- To know about automotive aerodynamics.
- To understand the construction of the car body, design criteria, types of car and safety aspects of car.
- To understand the construction of bus body and dimensions of bus body and safety aspects.
- To elaborate about the body panel refinishing, repair, paintwork, repainting, undercarriage rust proofing and sound dampening.

**Course Outcomes:**

On successful completion of this course, student will be able to

- C01: Explain the typical aerodynamic layout of vehicles.
- C02: Identify various car body components.
- C03: Identify various bus body components.
- C04: Identify various commercial vehicle body components.
- C05: Make use of vehicle body repair types and specific tools.



1021235130	<b>VEHICLE BODY ENGINEERING</b>	L	T	P	C
Practicum		2	0	2	3

**Pre-requisites:**

Knowledge of basic Science: Aerodynamics of cars, Body Building Technology.

**CO/PO Mapping**

CO / PO	P01	P02	P03	P04	P05	P06	P07
C01	2	2	2		2	1	1
C02	2	1			1	1	1
C03	2	1	1			1	1
C04	2	1		1	1	2	1
C05	3	2		1	2	2	

Legend: 3-High Correlation, 2-Medium Correlation, 1-Low Correlation

**Instructional Strategy:**

1. Vehicle vintage Models should be shown through video.
2. The subject can Lecture Cum Demonstration basics.
3. Practical demonstrations should be organized.



1021235130	<b>VEHICLE BODY ENGINEERING</b>	L	T	P	C
Practicum		2	0	2	3

**Assessment Methodology:**

	<b>Continuous Assessment (40 marks)</b>				<b>End Semester Examination (60 marks)</b>
	<b>CA1</b>	<b>CA2</b>	<b>CA3</b>	<b>CA4</b>	
<b>Mode</b>	Written Test Theory (Any Two Units)	Written Test Theory (Another Two Units)	Practical Test (All Exercises)	Written Test (Complete Theory Portions)	Written Examination (Complete Theory Portions)
<b>Duration</b>	2	2	3	3 Hours	3 Hours
<b>Exam Marks</b>	50	50	100	100	100
<b>Converted to</b>	10	10	15	15	60
<b>Marks</b>	10		15	15	60
<b>Tentative Schedule</b>	6th Week	12th Week	15th Week	16th Week	

Note:

- **CA1 and CA2:** Assessment written test should be conducted for 50 Marks. The marks scored will be converted to 10 Marks for each test. The best of one will be considered for the internal assessment of 10 Marks.

CA1 and CA2, Assessment written test should be conducted for two units as below.

Answer any Five questions. (5 X 10 Marks = 50 Marks).

Eight questions will be asked, students should write Five questions.

In each unit, Four questions can be asked. Each question may have subdivisions. A maximum of two subdivisions shall be permitted.



1021235130	<b>VEHICLE BODY ENGINEERING</b>	L	T	P	C
Practicum		2	0	2	3

- CA 3:** All the exercises/experiments should be completed and kept for the practical test. The students shall be permitted to select any one by lot for the test. The practical test should be conducted as per the scheme of evaluation as below. The marks awarded will be converted to 15 Marks for the internal mark.

Practical documents should be maintained for every exercise/experiment immediately after completion of the practice. The practical document should be submitted for the practical test. Each exercise/experiment should be evaluated for 10 Marks. The total marks awarded should be converted to 30 Marks for the practical test as per the scheme of evaluation as below.

**The details of the practical documents are to be prepared as per the instructions below.**

Each exercise / experiment procedure, observation and calculations should be completed on the day of practice. The same shall be evaluated for 10 marks on the day or the next day of practice before the commencement of the next exercise.

This documentation can be carried out in a separate notebook or a printed manual or a file with documents. The observation, reading, calculations, report, graphs and results should be written by the student manually in the practical documents.

The evaluated practical document should be submitted for the Practical Test (CA3). The marks scored by the students should be converted to 30 marks. The same should be included as per the allocation in the practical test.

The detailed dates of the practices and its evaluations should be maintained in the course logbook. The log book and the practical documents should be submitted for the verification by the Flying Squad and DOTE Official.



1021235130	<b>VEHICLE BODY ENGINEERING</b>	L	T	P	C
Practicum		2	0	2	3

**SCHEME OF EVALUATION - Practical Test**

Sl.No.	Description	Marks
A	Aim / Tools required	10
B	Procedure / Observation	20
C	Report	20
D	Result	10
E	Practical document (All Practicals)	30
F	Viva Voce	10
Total		100

**CA4:** Model examination should be conducted for complete theory portions as per the end-semester question pattern. The marks awarded should be converted to 15 marks for the internal assessment.

**Question Pattern:**

Answer Ten questions by selecting two questions from each unit. Each question carries 10 marks each.

Four questions will be asked from every unit, students should write any two questions. The question may have two subdivisions only.



1021235130	<b>VEHICLE BODY ENGINEERING</b>	L	T	P	C
Practicum		2	0	2	3

### Syllabus Contents

<b>Unit I</b>	<b>Vehicle Aerodynamics</b>			
<b>Theory:</b> Vehicle Aerodynamics , Objectives, Vehicle Drag - Definition, Types and Effects. Forces and Moments Acting on Vehicle Body - Types and Effects. Various Body Optimization Techniques and Aerodynamic Aids for Optimization of Drag. Drag Reducing Devices in Commercial Vehicles. Component Balance to Measure Forces and Moments. Problems of vehicle modification.				6
<b>Practical:</b>				6
<b>Exercise 1:</b> To prepare the report for recommended troubleshooting procedure as per Workshop manual for a) Abnormal wear b) Wheel wobbling c) Poor self centering d) Hard steering.				
<b>Exercise 2:</b> To prepare the report for wheel Alignment acceptable limits (minimum angle to maximum angle).				
<b>Unit II</b>	<b>Car Bodies</b>			
<b>Theory:</b> Car Body-Purpose, Requirements and Types - Saloon, Convertibles, Limousine, Estate Van, Racing and Sports Car. Car Body Construction - Components of Car Body and Purpose of Each Component. Safety Equipment for Car - Seat Belts and Airbags. Crash Test and Roll Over Test.				6
<b>Practical:</b>				6
<b>Exercise 3:</b> Identify body parts and give reports for Diesel engine cars of two different companies LMV.				
<b>Exercise 4:</b> Identify body parts and give reports for Petrol engine cars of two different companies LMV.				



1021235130	<b>VEHICLE BODY ENGINEERING</b>	L	T	P	C
Practicum		2	0	2	3

<b>Unit III</b>	<b>Bus Bodies</b>		
<b>Theory:</b>	Bus Body – Types - Minibus, Single Decker, Double Decker, Two Level, Split Level and Articulated Bus. Bus Body Layout - Floor Height - Engine Location - Entrance and Exit Location - Seating Dimensions. Constructional Details - Frame Construction - Types of Metal Section Used, Double Skin Construction, Conventional and Integral Type Construction. Types of door system.	6	
<b>Practical: Exercise 5:</b>	Identify different major components of heavy vehicles body construction and their function.	3	
<b>Unit IV</b>	<b>Commercial Vehicle Bodies and Materials</b>		
<b>Theory:</b>	Types of Commercial Vehicle Body - Light Commercial Vehicle Body Types, Flat Platform, Drop Side, Fixed Side, Tipper Body, Tanker Body - Baffled and Unbaffled Tanks, Drivers Cab Design - Forward Control Cab and Normal Control Cab. Vehicle Body Materials - Steel, Light Alloys, Plastics, Crp, Grp, Textiles, Glass, Wood, Aluminium Materials, Adhesives and their Properties.	6	
<b>Practical: Exercise 6:</b>	Identify different major components of commercial vehicle body construction and their function.	3	
<b>Unit V</b>	<b>Body Materials, Maintenance and Surface Finish</b>		
<b>Theory:</b>	Steel sheet, Aluminium, Timber, Plastics, GRP, PRP properties of materials – corrosion-Anti corrosion methods – Body panel, tools for repairing, Tinkering ,soldering and use of metalloid paste. Surface finish: Painting process – Electroplating of components – Vacuum coating, Electrostatic painting.	5	
<b>Practical: Exercise 7:</b>	Study and prepare a report of body painting service. (like small hole or deep scratch)	3	
		Test + Revision	10
		TOTAL HOURS	60



1021235130	<b>VEHICLE BODY ENGINEERING</b>	L	T	P	C
Practicum		2	0	2	3

**Suggested List of Students Activity:**

- Visit the automobile body building industry and prepare a report.
- Prepare a report about the various types of body.

**Text book for Reference:**

1. Vehicle Body Engineering, Powloski, J., Business Books Ltd, 1989.
2. Body Repair Technology for 4-Wheelers, James E Duffy, Cengage Learning.
3. Body construction and design, Giles, G.J., Illiffe Books Butterworth & Co.
4. The Repair of vehicle bodies, Andrew Livesey and A Robinson, Routledge.
5. John Fenton, "Handbook of Automotive Body and Systems Design", John Wiley & Sons, 2013.
6. Kirpal Singh, "Automobile Engineering", Standard publishers, Distributors, Delhi.

**Web-based/Online Resources:**

1. <https://www.youtube.com/watch?v=zSKtwgX8wpc>
2. <https://www.youtube.com/watch?v=3W3mJJbnwNg>
3. <https://www.youtube.com/watch?v=ZQSWg6gAebw>
4. <https://www.youtube.com/watch?v=1sP9Ty0jQy8>
5. [https://www.youtube.com/watch?v=ORFa\\_iPtAeY](https://www.youtube.com/watch?v=ORFa_iPtAeY)
6. <https://www.youtube.com/watch?v=l30lxtpWX7Y>



1021235130	<b>VEHICLE BODY ENGINEERING</b>	L	T	P	C
Practicum		2	0	2	3

**Equipment / Facilities required to conduct the Practical Course.**

1. 3D wheel alignment test. - Quantity as per the requirement.
2. Various Company LMV/HMV body structure - Quantity as per the requirement.
3. Various Company passenger vehicles/goods carrying vehicle body frames. - Quantity as per the requirement.
4. Body painting basic tools. - Quantity as per the requirement.



1021235130	<b>VEHICLE BODY ENGINEERING</b>	L	T	P	C
Practicum		2	0	2	3

**END SEMESTER QUESTION PATTERN - Theory Exam**

**Duration: 3 Hrs.**

**Max. Marks: 100**

**Note:** Answer Ten questions by selecting two questions from each unit. Each question carries 10 marks each.

**Instruction to the Question Setters**

Four questions will be asked from every unit, students should write any two questions for 10 marks. The question may have two subdivisions only.



1021235230	<b>Electric Vehicle technology &amp; Policy</b>	L	T	P	C
Practicum		3	0	2	4

**Introduction:**

The world is transitioning to cleaner mobility options with the aim at improving air quality and reducing dependency on fossil fuels. Electric Vehicles (EVs) have emerged as a popular clean mobility choice to reduce emissions. EVs are powered fully or partially by batteries, they can help to reduce dependence on fossil fuels and also air quality. Tamil Nadu is one of the most advanced states in India. Tamil Nadu has a highly developed industrial ecosystem and is very strong in sectors like automobiles and auto components. Many globally renowned companies have set up their manufacturing facilities in Tamil Nadu. Due to the rapid depletion of fossil fuel and increase in fuel cost, environmental pollution, the shift to clean transport is necessary.

**Course Objectives:**

The objective of this course is to enable the students to

- Learn the environmental impact and history of Electric Vehicles and types of Electric vehicles.
- Understand and test the concept of EV and subsystems.
- Describe the configurations of hybrid Electric Vehicles
- Summarize the E-Mobility and Tamil Nadu EV Policy.

**Course Outcomes:**

On successful completion of this course, the student will be able to

C01: Understand the environmental impact of Electric Vehicles and their types.

C02: Describe the EV battery and charging system.

C03: Apply the procedures of testing of battery, EV motor, electric bicycle and subsystem.

C04: Identify the various drive trains and working modes of Hybrid Electric vehicles.

C05: Summarize the E-mobility and Electric vehicle policy.

**Pre-requisites:**

Knowledge of Automotive engines, Automobile Electric & Electronics and Power Units & Transmission.



1021235230	<b>Electric Vehicle technology &amp; Policy</b>	L	T	P	C
Practicum		3	0	2	4

### CO/PO Mapping

CO / PO	P01	P02	P03	P04	P05	P06	P07
<b>C01</b>	2	-	-	-	1	-	-
<b>C02</b>	2	1	-	-	-	-	1
<b>C03</b>	2	1	-	-	-	-	1
<b>C04</b>	2	-	-	-	2	1	1
<b>C05</b>	2	1	1	2	-	-	1

Legend: 3-High Correlation, 2-Medium Correlation, 1-Low Correlation

### Instructional Strategy:

- Engage and Motivate: Instructors should actively engage students to boost their learning confidence.
- Real-World Relevance: Incorporate relatable, real-life examples and engineering applications to help students understand and appreciate course concepts.
- Interactive Learning: Utilize demonstrations and plan interactive student activities for an engaging learning experience.
- Application-Based Learning: Employ a theory-demonstrate-practice-activity strategy throughout the course to ensure outcome-driven learning and employability.
- Simulation and Real-World Practice: Conduct demonstrations and hands-on activities in a simulated environment, transitioning to real-world scenarios when possible.
- Encourage Critical Analysis: Foster an environment where students can honestly assess experiment outcomes and analyze potential sources of error in case of discrepancies.
- The industry session shall be addressed by industry experts (in contact mode/online / recorded video mode) in the discipline only.



1021235230	<b>Electric Vehicle technology &amp; Policy</b>	L	T	P	C
Practicum		3	0	2	4

**Assessment Methodology:**

	<b>Continuous Assessment (40 marks)</b>				<b>End Semester Examination (60 marks)</b>
	<b>CA1</b>	<b>CA2</b>	<b>CA3</b>	<b>CA4</b>	
<b>Mode</b>	Written Test Theory (Any Two Units)	Written Test Theory (Another Two Units)	Practical Test (All Exercises)	Written Test (Complete Theory Portions)	Written Examination (Complete Theory Portions)
<b>Duration</b>	2	2	3	3 Hours	3 Hours
<b>Exam Marks</b>	50	50	100	100	100
<b>Converted to</b>	10	10	15	15	60
<b>Marks</b>	10		15	15	60
<b>Tentative Schedule</b>	6th Week	12th Week	15th Week	16th Week	

Note:

- **CA1 and CA2:** Assessment written test should be conducted for 50 Marks. The marks scored will be converted to 10 Marks for each test. The best of one will be considered for the internal assessment of 10 Marks.

CA1 and CA2, Assessment written test should be conducted for two units as below.

Answer any Five questions. (5 X 10 Marks = 50 Marks).

Eight questions will be asked, students should write Five questions.



1021235230	<b>Electric Vehicle technology &amp; Policy</b>	L	T	P	C
Practicum		3	0	2	4

In each unit, Four questions can be asked. Each question may have subdivisions. A maximum of two subdivisions shall be permitted.

- **CA 3:** All the exercises/experiments should be completed and kept for the practical test. The students shall be permitted to select any one by lot for the test. The practical test should be conducted as per the scheme of evaluation as below. The marks awarded will be converted to 15 Marks for the internal mark.

Practical documents should be maintained for every exercise/experiment immediately after completion of the practice. The practical document should be submitted for the practical test. Each exercise/experiment should be evaluated for 10 Marks. The total marks awarded should be converted to 30 Marks for the practical test as per the scheme of evaluation as below.

**The details of the practical documents are to be prepared as per the instructions below.**

Each exercise / experiment procedure, observation and calculations should be completed on the day of practice. The same shall be evaluated for 10 marks on the day or the next day of practice before the commencement of the next exercise.

This documentation can be carried out in a separate notebook or a printed manual or a file with documents. The observation, reading, calculations, report, graphs and results should be written by the student manually in the practical documents.

The evaluated practical document should be submitted for the Practical Test (CA3). The marks scored by the students should be converted to 30 marks. The same should be included as per the allocation in the practical test.

The detailed dates of the practices and its evaluations should be maintained in the course logbook. The log book and the practical documents should be submitted for the verification by the Flying Squad and DOTE Official.



1021235230	<b>Electric Vehicle technology &amp; Policy</b>	L	T	P	C
Practicum		3	0	2	4

**SCHEME OF EVALUATION - Practical Test**

Sl.No.	Description	Marks
A	Aim & Apparatus required	10
B	Procedure / Explanation	20
C	Observation/ Assembly / Reading	20
D	Report / Result	10
E	Practical document (All Practicals)	30
F	Viva Voce	10
Total		100

**CA4:** Model examination should be conducted for complete theory portions as per the end-semester question pattern. The marks awarded should be converted to 15 marks for the internal assessment.

**Question Pattern:**

Answer Ten questions by selecting two questions from each unit. Each question carries 10 marks each.

Four questions will be asked from every unit, students should write any two questions. The question may have two subdivisions only.



1021235230	<b>Electric Vehicle technology &amp; Policy</b>	L	T	P	C
Practicum		3	0	2	4

### Syllabus Contents

<b>Unit I</b>	<b>Environmental impact and history and E-Vehicles</b>			
<p>Environmental impact and history: Environmental impact of conventional vehicles - Air pollution – Petroleum resources – History of Electric vehicles &amp; Hybrid Electric Vehicles – Need for Electric Vehicle.</p> <p>Electric vehicle Types – Definition BEV – Major Components of Electric Vehicle –Block diagram and working of BEV - Different between BEV and Conventional Vehicle.</p> <p>Fuel Cell – Working Principle - Fuel Cell-operated Electric Vehicle (FCEV) - Major component - Working principle - Advantages.</p>				9
<b>Unit II</b>	<b>Electric Vehicle Battery Technology and Charging Methods</b>			
<p>Battery: Electrochemical Batteries – Battery Technologies – Construction and working of Nickel-cadmium, Nickel-ion, Lithium-ion, and lithium-polymer batteries – Ultracapacitor - Battery Management System (BMS) – Battery pack development Technology: series, Parallel and mixed connection to develop battery pack.</p> <p>Battery Charging Techniques: Battery Charging techniques – Constant current and Constant voltage, Trickle charging – Battery Swapping Techniques – DC charging – Wireless charging – Maintenance of Battery pack.</p>				9
<b>Unit III</b>	<b>Electric propulsion system and Converters</b>			
<p>Configurations of Electric Vehicle –Electric power drivetrain – Performance of Electric Vehicles – Tractive Effort in Normal Driving.</p> <p>EV motors - Types - Principles, Construction, Working, Merits and Demerits of DC motor drives, Permanent Magnetic Brushless DC Motor Drives - Hub motor Drive system.</p> <p>Power Converters: Role of Power Converters – Block diagram of Power Converters in EV – Types of Power Converters – DC to DC Converter, Inverter and Rectifier and its types.</p>				9



1021235230	<b>Electric Vehicle technology &amp; Policy</b>	L	T	P	C
Practicum		3	0	2	4

<b>Unit IV</b>	<b>Hybrid Electric Vehicle</b>	
<p>HEV: Hybrid Electric Vehicle – Advantages, Disadvantages – Components of Hybrid Electric Vehicle – IC Engine, Electric Motor, Controller, DC/DC Converter, Transmission, Batteries – Working of Hybrid Vehicle – Starting, Braking, Cruising, Passing. -- Plug-in Hybrid Electric Vehicle</p> <p>Types of Hybrid Vehicle: Hybridisation – Micro Hybrid, Mild Hybrid, Fully Hybrid – Advantages, Disadvantages &amp; its Applications.</p> <p>Drive Configuration: Series Hybrid – Control Strategies, Advantages &amp; Disadvantages, Configuration - Parallel Hybrid –Control Strategies, Advantages &amp; Disadvantages, Configuration – Split Power Hybrid.</p>		9
<b>Unit V</b>	<b>ELECTRIC MOBILITY AND ELECTRIC VEHICLE POLICIES</b>	
<p>Electric mobility ecosystem- Global scenario of EV adoption - Electric mobility in India - National Electric Mobility Mission Plan 2020 (NEMMP 2020) - FAME, India (Faster Adoption and Manufacturing of (Hybrid &amp; Electric) Vehicles in India) I &amp; II - Champion OEM Incentive Scheme - Recycling Ecosystem of battery and EVs - Battery Recycling. TAMIL NADU ELECTRIC VEHICLES POLICY 2019 - Key Features.</p> <p>TAMIL NADU ELECTRIC VEHICLES POLICY 2023: Need for a Revised Policy - Scope &amp; Definitions – Objectives - Supply Side Policy Measures - Demand Side Measures - Charging Infrastructure - Ecosystem Development - Policy Implementation Mechanism.</p>		9



1021235230	<b>Electric Vehicle technology &amp; Policy</b>	L	T	P	C
Practicum		3	0	2	4

<b>Practical:</b>	20
<b>Experiment 1:</b> Test the Lead-acid Battery using a voltage Load tester and test the battery pack supply to glow the Headlamp	
<b>Experiment 2:</b> Test the battery charging (battery in series and Parallel) and note the various charging parameters.	
<b>Experiment 3:</b> Identify and test the components of the electric two-wheeler (Battery, power key, Controller, Throttle, EV motor, Brake, Headlight, Speedometer, Indicator and Horn)	
<b>Experiment 4:</b> Construct and test the BLDC Motor with throttle control.	
<b>Experiment 5:</b> Assemble and test the E-bicycle.	
<b>Experiment 6:</b> Assemble and test e-bike with central drive mechanism (Chaindrive) wiring harness.	
<b>Experiment 7:</b> Test DC-DC converter and DC-AC converter.	
	Test + Revision 10
	TOTAL HOURS 75

**Suggested List of Student Activity:**

- Presentation/Seminars by students on any recent technological developments based on the course.
- Poster presentation on layout and wiring harness of electric Two-wheeler / Four-wheeler.

**Text book for Reference:**

1. A.K Babu, Electric & Hybrid Vehicle, Second edition, Khanna Publication, 2022.
2. James D. Halderman, Electric and Hybrid Electric Vehicles, First edition Pearson, 2023.
3. Mehrdad Ehsani, Yimin Gao, Sebastien E.Gay, Ali Emadi, Modern Electric, Hybrid Electric and Fuel Cell Vehicles, Third edition, CRC Press, 2019.
4. Tamil Nadu Electric Vehicles Policy 2019 & 2023.



1021235230	<b>Electric Vehicle technology &amp; Policy</b>	L	T	P	C
Practicum		3	0	2	4

**Web-based/Online Resources:**

- NPTEL Fundamentals of Electric vehicles: Technology & Economics  
<https://nptel.ac.in/courses/108106170>
- NPTEL Introduction to Hybrid and Electric Vehicles, IIT Guwahati  
<https://nptel.ac.in/courses/108103009>

**END SEMESTER QUESTION PATTERN - Theory Exam**

**Duration: 3 Hrs.**

**Max. Marks: 100**

**Note:** Answer Ten questions by selecting two questions from each unit. Each question carries 10 marks each.

**Instruction to the Question Setters**

Four questions will be asked from every unit, students should write any two questions for 10 marks. The question may have two subdivisions only.



1021235230	<b>Electric Vehicle technology &amp; Policy</b>	L	T	P	C
Practicum		3	0	2	4

**Equipment / Facilities required to conduct the Practical Course.**

Sl. No.	Machines / Tools / Equipment	Quantity
1.	Lead acid battery / Lithium-ion Battery	8 Nos
2.	Battery Load tester	1 No
3.	Battery Charger Unit with Lead Acid battery	2 Nos
4.	Two-wheeler Wiring Harness board or kit	1 No
5.	DC -DC Converter Trainer Kit	1 No
6.	DC -AC Converter Trainer Kit	1 No
7.	E – Bicycle kit or Accessories 24V DC Controller, 24 V DC motor, Throttle, Brake, Power ON key, Headlamp with Horn.	1 No
8.	E – Bike kit or Accessories 48 V BLDC Controller, 500W or 750 W, 48 V BLDC motor, Throttle, Brake, Power ON key, Display Board, Head lamp with Horn, Left & Right Indicator	1 No
9.	Consumable: - Battery Cell - 1.5 V or 3.65 V , Soldering Iron , Flux, De-solder gun or Solder wick, Lead Tools: - Continuity Tester, Line Tester, Multi-meter, Hydrometer, Screw Drive set & Spanner set	As per requirement.



1021235311	<b>Tractor and Farm Equipment</b>	L	T	P	C
THEORY		3	0	0	3

**Introduction:**

Farm equipment provides higher work output rates to sustain higher demand for increased agricultural production. Farm tools, implements, and equipment play a very important role in horticultural operations. Their availability makes the work much easier and faster. However, even if one may have the most sophisticated tools and implements, but does not know how to use them, they are useless. This subject is designed to understand the basic farm equipment.

**Course Objectives:**

At the end of the course, the students will be able

- ☒ To learn the types of tractors and its operating principles.
- ☒ To study about the ploughing implements.
- ☒ To understand the harvesting and threshing equipment.
- ☒ To address the fertilizers and equipment used for it.
- ☒ To know the maintenance procedure of tractors

**Course Outcomes:**

On successful completion of this course, the student will be able to

- C01: Determine the appropriate tractor types can impact performance faster and accurate for the different agricultural fields.
- C02: Select the proper ploughing Implements to defend the soil from hardening and lack of growth of microbes and identify the soil types.
- C03: Learn the Modern harvesting methods to decrease the grain waste, improves grain quality and quantity and mention the appropriate harvesting methods.
- C04: Differentiate the methods of advance machinery in fertilizing process in generalize and identify the suitable fertilizer.
- C05: Understand the farm equipments and practices to prevent breakdowns and accidents and suggest suitable remedial process.



1021235311	<b>Tractor and Farm Equipment</b>	L	T	P	C
THEORY		3	0	0	3

**Pre-requisites:**

Knowledge of basic power units and Transmission systems.

**CO/PO Mapping**

CO / PO	P01	P02	P03	P04	P05	P06	P07
<b>C01</b>	3	3	2	2	3	2	2
<b>C02</b>	2	3	3	3	3	2	3
<b>C03</b>	3	3	3	3	2	3	2
<b>C04</b>	3	3	3	3	3	3	3
<b>C05</b>	3	3	2	3	2	2	3

Legend: 3-High Correlation, 2-Medium Correlation, 1-Low Correlation

**Instructional Strategy:**

- By student centric teaching allows the student to understand more about the topics and concepts in a classroom
- Using visual audio teaching improves learning the concepts easily.
- Teacher provides information, the students watch, listen and learn from the direct teaching methods.



1021235311	<b>Tractor and Farm Equipment</b>	L	T	P	C
THEORY		3	0	0	3

### Assessment Methodology

	Continuous Assessment (40 marks)				End Semester Examination (60 marks)
	CA1	CA2	CA3	CA4	
<b>Mode</b>	Written test (Two units)	Written test (Another Two units)	Quiz MCQ (Online / Offline)	Model Examination	Written Examination
<b>Duration</b>	2 Periods	2 Periods	1 Hour	3 Hours	3 Hours
<b>Exam Marks</b>	50	50	60	100	100
<b>Converted to</b>	15	15	5	20	60
<b>Marks</b>	15		5	20	60
<b>Tentative Schedule</b>	6th Week	12th Week	13 -14th Week	16th Week	

**CA1 and CA2:** Assessment written test should be conducted for 50 Marks for two units. The marks scored will be converted to 15 Marks. Best of one will be considered for the internal assessment of 15 Marks.

CA1 and CA2, Assessment test should be conducted for two units as below.

Answer any five questions (5 X 10 Marks = 50 Marks).

Eight questions will be asked, students should write Five questions. Each unit Four questions can be asked. Each question may have subdivisions. Maximum two subdivisions shall be permitted.

**CA3:** 60 MCQ can be asked by covering the entire portion. It may be conducted by Online / Offline. The answer scripts of every student (online / offline) for this assessment should be kept for records and future verification. The marks scored should be converted to 5 marks for the internal assessment



1021235311	<b>Tractor and Farm Equipment</b>	L	T	P	C
THEORY		3	0	0	3

**CA4:** Model examination should be conducted as per the end-semester question pattern. The marks should be converted to 20 marks for the internal assessment.

**Question Pattern:**

Answer ten questions by selecting two questions from each unit. Each question carries 10 marks each.

Four questions will be asked from every unit, students should write any two questions. The question may have two subdivisions only.

**Syllabus Contents**

<b>Unit I</b>	<b>General Design of Tractors and Accessories</b>	
	Classification of Tractors: Track laying tractor – heavy wheeled tractors – general purpose tractors – two wheeled tractors. Main components of Tractor - Power Take Off Shaft (PTO) – Belt pulley – The tractor hydraulic system – operating principle	7
<b>Unit II</b>	<b>Ploughing Implements</b>	
	Primary and Secondary Tillage equipment - DISC Plough – Mould Board Plough – Tiller and Harrows – Construction – furrow mounted plough – ploughing methods - systematic ploughing, round and round ploughing and one way ploughing - hitching – Three point linkage – Cage Wheel and its uses	7
<b>Unit III</b>	<b>Harvesting and Threshing Equipments</b>	
	Harvesting – conventional and Modern Harvesters – Threshing – combine harvester– cultivators – uses of cultivator – disc harrows – spring tine cultivator – seed harrows – chain harrows – rotary cultivator – uses. Corn drills – seed metering mechanisms – potato crop machinery – sugar beet crop machinery.	7



1021235311	<b>Tractor and Farm Equipment</b>	L	T	P	C
THEORY		3	0	0	3

<b>Unit IV</b>	<b>Sprayers and Dusters</b>			
Classification of sprayers and dusters Manual and Power sprayers and Dusters – components of sprayers and dusters – different pumps, nozzles, used in sprayers. rotating plate and flicker fertilizer unit – spinning disc type – the spreader mechanism – Hay Making machinery – Forage harvester.				7
<b>Unit V</b>	<b>Maintenance of Tractors</b>			
Daily Maintenance of Tractors – Maintenance of Tractors on hour basis – Troubleshooting of Tractor engines, clutch, Gearbox – Major overhaul of engines. Maintenance of the plough – routine maintenance of cultivating machinery – maintenance to grain drills – maintenance of fertilizer distributor – maintenance of farmyard manure spreaders.				7
Test + Revision				10
Total Hours				45

**Suggested List of Students Activity:**

- Have a field trip to different agricultural fields and soil testing laboratories.
- Advice to collect and prepare troubleshooting methods manual for different machineries.
- Encourage to collect different farm manufactures details specification of farm vehicles.

**Text book for Reference:**

1. Elements of Agricultural Engineering Jagdishwar Sahay.
2. Farm Tractor– Maintenance and Repair S.C.Jain, C.T.Raj, TATA MC Graw Hill.
3. Farm Machinery and Equipment – Smith & Wilkey, Tata MC Graw Hill.
4. Elements of Agricultural Engineering - Dr.Jagdiswar Sahay.
5. Farm Machinery – An approach Authors: S.C. Jain & Grace Philip. Standard Publishers, Distributors,1705,Nai Sarak, P.B.NO.1066, New Delhi.
6. Basic Farm Machinery, JM Shippen and JC Turner, Pergamon International Library.- Second edition.



1021235311	<b>Tractor and Farm Equipment</b>	L	T	P	C
THEORY		3	0	0	3

**Web-based / Online Resources:**

- <https://nptel.ac.in/courses/126/105/126105009/>

**END SEMESTER QUESTION PATTERN - THEORY EXAM**

**Duration: 3 Hrs.**

**Max. Marks: 100**

**Note:** Answer Ten questions by selecting two questions from each unit. Each question carries 10 marks each.

**Instruction to the Question Setters**

Four questions will be asked from every unit, students should write any two questions for 10 marks. The question may have two subdivisions only.



1021235312	<b>VEHICLE AERODYNAMICS AND DESIGN</b>	L	T	P	C
THEORY		3	0	0	3

### Introduction

The purpose of studying aerodynamics helps to understand the principles governing airflow around vehicles and its impact on performance, efficiency, and safety. It helps in optimizing fuel efficiency, improving speed and handling, enhancing safety, reducing environmental impact, and fostering innovation in vehicle design. This course help students with the essential skills and knowledge needed to design vehicles with optimal aerodynamic characteristics, contributing to advancements in automotive technology and sustainability

### Course Objectives

The objective of this course is to enable the student to

- To gain knowledge of fluid mechanics fundamentals related to vehicle motion
- To analyse drag forces to develop strategies for achieving low drag profiles.
- To become familiar with the shape optimization methods used in the passenger car sector
- To study vehicle dynamics under side winds and assess characteristics of forces and moments.
- To give insight to wind tunnel and testing techniques practiced in industry.

### Course Outcomes

On successful completion of this course, the student will be able to

CO1: Knowledge upon resistance to vehicle motion.

CO2: Calculate drag coefficients for optimizing vehicle performance and efficiency.

CO3: Appraise upon the techniques of shape-based optimization practiced in industry

CO4: Understand the effects of side winds on vehicle dynamics

CO5: Expose to fundamentals of Experimental testing.

### Pre-requisites

Fundamentals of Fluid Mechanics which include concepts such as properties of fluids, turbulence, Bernoulli's principle and boundary layers.



1021235312	<b>VEHICLE AERODYNAMICS AND DESIGN</b>	L	T	P	C
THEORY		3	0	0	3

### CO/PO Mapping

CO / PO	PO1	PO2	PO3	PO4	PO5	PO6	PO7
<b>C01</b>	3	2	2	3	1	1	1
<b>C02</b>	3	3	2	3	1	2	1
<b>C03</b>	2	3	3	3	1	2	1
<b>C04</b>	2	3	3	3	1	2	1
<b>C05</b>	3	2	2	2	1	1	1

Legend: 3-High Correlation, 2-Medium Correlation, 1-Low Correlation

### Instructional Strategy:

- Engage and Motivate: Instructors should actively engage students to boost their confidence.
- Real-World Relevance: Incorporate relatable, real-life examples and engineering applications to help students understand and appreciate course concepts.
- Interactive Learning: Utilize demonstrations and plan interactive student activities for an engaging learning experience.
- Application-Based Learning: Employ a theory-demonstrate-practice-activity strategy throughout the course to ensure outcome-driven learning and employability.
- Simulation and Real-World Practice: Conduct demonstrations and hands-on activities in a simulated environment, transitioning to real-world scenarios when possible.
- Encourage Critical Analysis: Foster an environment where students can honestly assess experiment outcomes and analyze potential sources of error in case of discrepancies.



1021235312	<b>VEHICLE AERODYNAMICS AND DESIGN</b>	L	T	P	C
THEORY		3	0	0	3

### Assessment Methodology

	Continuous Assessment (40 marks)				End Semester Examination (60 marks)
	CA1	CA2	CA3	CA4	
<b>Mode</b>	Written test (Two units)	Written test (Another Two units)	Quiz MCQ (Online / Offline)	Model Examination	Written Examination
<b>Duration</b>	2 Periods	2 Periods	1 Hour	3 Hours	3 Hours
<b>Exam Marks</b>	50	50	60	100	100
<b>Converted to</b>	15	15	5	20	60
<b>Marks</b>	15		5	20	60
<b>Tentative Schedule</b>	6th Week	12th Week	13-14th Week	16th Week	

**CA1 and CA2:** Assessment written test should be conducted for 50 Marks for two units. The marks scored will be converted to 15 Marks. Best of one will be considered for the internal assessment of 15 Marks.

CA1 and CA2, Assessment test should be conducted for two units as below.

Answer any five questions (5 X 10 Marks = 50 Marks).

Eight questions will be asked, students should write Five questions. Each unit Four questions can be asked. Each question may have subdivisions. Maximum two subdivisions shall be permitted.

**CA3:** 60 MCQ can be asked by covering the entire portion. It may be conducted by Online /Offline. The answer scripts of every student (online / offline) for this assessment should be kept for records and future verification. The marks scored should be converted to 5 marks for the internal assessment



1021235312	<b>VEHICLE AERODYNAMICS AND DESIGN</b>	L	T	P	C
THEORY		3	0	0	3

**CA4:** Model examination should be conducted as per the end-semester question pattern. The marks should be converted to 20 marks for the internal assessment.

**Question Pattern:**

Answer Ten questions by selecting two questions from each unit. Each question carries 10 marks each.

Four questions will be asked from every unit, students should write any two questions. The question may have two subdivisions only.

**Syllabus Contents**

<b>Unit I</b>	<b>SCOPE OF VEHICLE AERODYNAMICS</b>	
	Scope – historical development trends – Fundamentals of fluid mechanics – Flow phenomenon related to vehicles – External & Internal flow problems – Resistance to vehicle motion – Performance – Fuel consumption and performance – Potential of vehicle aerodynamics.	7
<b>Unit II</b>	<b>AERODYNAMIC DRAG OF CARS</b>	
	Car as a bluff body – Flow field around car – drag force – types of drag force – analysis of aerodynamic drag – drag coefficient of cars – strategies for aerodynamic development – low drag profiles.	7
<b>Unit III</b>	<b>SHAPE OPTIMIZATION OF CARS</b>	
	Front and modification – front and rear windshield angle – Boat tailing – Hatchback, fast back and square back – Dust flow patterns at the rear – Effect of gap configuration – effect of fasteners.	7



1021235312	<b>VEHICLE AERODYNAMICS AND DESIGN</b>	L	T	P	C
THEORY		3	0	0	3

<b>Unit IV</b>	<b>VEHICLE HANDLING</b>			
The origin of force and moments on a vehicle – side wind problems – methods to calculate forces and moments – vehicle dynamics Under side winds – the effects of forces and moments – Characteristics of forces and moments – Dirt accumulation on the vehicle – wind noise – drag reduction in commercial vehicles.				7
<b>Unit V</b>	<b>WIND TUNNELS, MEASUREMENT AND TEST TECHNIQUES</b>			
Fundamentals of Wind Tunnel Technique, Tests with Reduced-Scale Models Details of Model Construction and Test Technique, Reynolds Number Effects, Climatic Tunnels. Measuring Equipment and Transducers - Measurement of Aerodynamic Forces and Moments, Pressure Measurements, Measurement of the Airflow Velocity, Temperature Measurement.				7
TEST + REVISION				10
TOTAL HOURS				45

**Text book for Reference:**

1. Hucho. W.H., “Aerodynamics of Road Vehicles – From Fluid Mechanics to Vehicle Engineering”, Society of Automotive Engineers, U.S, 1998 .
2. R.H.Barnard, “Road vehicle aerodynamic design, An Introduction”, Mechaero publications, Third edition, 2010.
3. Alan Pope, Jewel B. Barlow & William H. Rae, “Low speed wind tunnel testing”, published by John Wiley & Sons, Third edition, 1999.
4. T. Yomi Obidi, “Theory and Applications of Aerodynamics for Ground Vehicles” , SAE International, 2014.

**Web-based/Online Resources**

- <https://archive.nptel.ac.in/courses/101/105/101105088/>



1021235312	<b>VEHICLE AERODYNAMICS AND DESIGN</b>	L	T	P	C
THEORY		3	0	0	3

**END SEMESTER QUESTION PATTERN - THEORY EXAM**

**Duration: 3 Hrs.**

**Max. Marks: 100**

**Note:** Answer Ten questions by selecting two questions from each unit. Each question carries 10 marks each.

**Instruction to the Question Setters**

Four questions will be asked from every unit, students should write any two questions for 10 marks. The question may have two subdivisions only.



1021235313	<b>Heavy Vehicle Engineering</b>	L	T	P	C
THEORY		3	0	0	3

**Introduction:**

For decades a shortage of truck technicians existed throughout the world. The job opportunities and rates of pay in the trucking industry are increased. Good truck technicians are in high demand. The skill required of the truck technician is that of being a lifelong learner to keep abreast of the fast-changing technology of this industry.

**Course Objectives:**

The objective of this course is to enable the students to

- Identify the basic truck classifications.
- Describe the safety warnings in the work area.
- List some common tools used in heavy truck repair.
- Troubleshoot truck electrical circuit components.
- Understand the operation and maintenance of the transmission system.

**Course Outcomes:**

On successful completion of this course, the student will be able to

C01: Understand the truck classifications, shop floor safety and shop floor tools.

C02: Identify the Electrical system and service codes.

C03: Explain the sub system of Transmission of truck.

C04: Summarize the drive shafts and steering system of truck.

C05: Explain the suspension systems and brake systems.

**Pre-requisites:**

Knowledge of Automotive engines, Automobile Electric and Electronics and Power Units & Transmission, vehicle body engineering



1021235313	<b>Heavy Vehicle Engineering</b>	L	T	P	C
THEORY		3	0	0	3

**CO/PO Mapping**

CO / PO	P01	P02	P03	P04	P05	P06	P07
C01	1	-	-	1	1	-	1
C02	1	1	-	-	-	-	1
C03	1	-	-	-	-	-	1
C04	1	-	-	-	-	-	1
C05	1	-	-	-	-	-	1

Legend: 3-High Correlation, 2-Medium Correlation, 1-Low Correlation

**Instructional Strategy:**

- Engage and Motivate: Instructors should actively engage students to boost their learning confidence.
- Real-World Relevance: Incorporate relatable, real-life examples and engineering applications to help students understand and appreciate course concepts.
- Interactive Learning: Utilize demonstrations and plan interactive student activities for an engaging learning experience.
- Application-Based Learning: Employ a theory-demonstrate-practice-activity strategy throughout the course to ensure outcome-driven learning and employability.
- Simulation and Real-World Practice: Conduct demonstrations and hands-on activities in a simulated environment, transitioning to real-world scenarios when possible.
- Encourage Critical Analysis: Foster an environment where students can honestly assess experiment outcomes and analyze potential sources of error in case of discrepancies.
- The industry session shall be addressed by industry experts (in contact mode/online / recorded video mode) in the discipline only.
- Shop Floor visit to heavy vehicle service centre /Manufacturing unit



1021235313	<b>Heavy Vehicle Engineering</b>	L	T	P	C
THEORY		3	0	0	3

### Assessment Methodology

	Continuous Assessment (40 marks)				End Semester Examination (60 marks)
	CA1	CA2	CA3	CA4	
<b>Mode</b>	Written test (Two units)	Written test (Another Two units)	Quiz MCQ (Online / Offline)	Model Examination	Written Examination
<b>Duration</b>	2 Periods	2 Periods	1 Hour	3 Hours	3 Hours
<b>Exam Marks</b>	50	50	60	100	100
<b>Converted to</b>	15	15	5	20	60
<b>Marks</b>	15		5	20	60
<b>Tentative Schedule</b>	6th Week	12th Week	13-14th Week	16th Week	

**CA1 and CA2:** Assessment written test should be conducted for 50 Marks for two units. The marks scored will be converted to 15 Marks. Best of one will be considered for the internal assessment of 15 Marks.

CA1 and CA2, Assessment test should be conducted for two units as below.

Answer any five questions (5 X 10 Marks = 50 Marks).

Eight questions will be asked, students should write Five questions. Each unit Four questions can be asked. Each question may have subdivisions. Maximum two subdivisions shall be permitted.

**CA3:** 60 MCQ can be asked by covering the entire portion. It may be conducted by Online /Offline. The answer scripts of every student (online / offline) for this assessment should be kept for records and future verification. The marks scored should be converted to 5 marks for the internal assessment



1021235313	<b>Heavy Vehicle Engineering</b>	L	T	P	C
THEORY		3	0	0	3

**CA4:** Model examination should be conducted as per the end-semester question pattern. The marks should be converted to 20 marks for the internal assessment.

**Question Pattern:**

Answer Ten questions by selecting two questions from each unit. Each question carries 10 marks each.

Four questions will be asked from every unit, students should write any two questions. The question may have two subdivisions only.

**Syllabus Contents**

<b>Unit I</b>	<b>TRUCK CLASSIFICATIONS, SHOP SAFETY AND OPERATIONS</b>	
	Truck classifications: By Weight – By Wheel Number – Major Manufacturers – Components of Heavy Duty Truck – Career Opportunities for Heavy Duty Truck Technicians. Shop Safety and Operations. Personal Safety - Work Area Safety – Fire Safety – Hazardous Materials – Handling and Disposal of Hazardous Waste. Tools: Hand Tools – Power Tools – Measuring Tools. Fasteners: Grades and Glasses – Fastener Replacement – Repairing Damaged threads – Riveting. Preventive Maintenance –Lubricants – Winterizing	7
<b>Unit II</b>	<b>ELECTRICAL SYSTEMS</b>	
	Electrical Motor and Generator principle – Coils – Transformers and Solenoids – Battery Operating Principles – Battery Ratings – Battery Maintenance – Charging Safety – Jump Starting – Battery Storage and Recycling Procedure. Trailer circuit connector – Panel component – Rapid checking of a truck electrical circuit. Electronic Service tools (EST) – Flash or Blink codes – Prolink 9000 – SAE / ATA J 1587 / J 1708 / J 1939 Codes and Protocols – Electrical Wiring, Connector and Terminal repair.	7



1021235313	<b>Heavy Vehicle Engineering</b>	L	T	P	C
THEORY		3	0	0	3

<b>Unit III</b>	<b>TRANSMISSION SYSTEM</b>			
<p>Clutch: Clutch Function – Components – Clutch Brakes – Clutch Linkages – Troubleshooting – Periodic Maintenance.</p> <p>Gear box : Gears – Gear Train configurations – Gear shift Mechanisms – Gear shift Lever – Counter shaft gear train – Air operated gear shift system – Eighteen Speed Transmission– Deep reduction Transmissions.</p> <p>Transmission: Transmission Servicing – Lubrication – Preventive Maintenance Inspection– Troubleshooting – Overhauling the transmission – Torque converter Components.</p> <p>Automatic Transmissions – Simple Planetary Gear Sets – Components – Working principle – Hydraulic control Five Speed transmission - Electronic Control transmissions.</p>				7
<b>Unit IV</b>	<b>DRIVE SHAFTS AND STEERING SYSTEM</b>			
<p>Drive Shafts: Construction – Drive shaft inspection – Drive Axles – Differential Gearing Types – Single Reduction Axle – Double Reduction Axle- Tandem Drive Axle – Drive Axle Failures.</p> <p>Steering system: Components – Steering system inspection -Axle Alignment – Electronic Alignment Equipment – Steering Axle Inspection – Overhaul – Manual Steering Gears – Power Steering Systems – Air Assisted Steering Systems – Electronically Variable Steering – Load Sensing power Steering.</p>				7
<b>Unit V</b>	<b>SUSPENSION SYSTEMS AND BRAKE SYSTEMS</b>			
<p>Suspension Systems: Types – Front Suspension – Rear Suspension – Single axle spring suspension – tandem axle spring suspension – Spring suspension with shock absorbers – Equalizing beam suspension system: Leaf spring type – rubber cushion type – Air spring suspensions – components – Air spring mechanics – Cab Air Suspension.</p> <p>Brake systems: Air Brake System – Components - Truck air brake system – Trailer air brake system. Hydraulic Brake systems – Components – Hydraulic Drum Brake – Air Over Hydraulic Brake systems – Hydraulic Brake Service Procedures – Automatic Traction Control Systems – Fifth Wheel.</p>				7
TEST + REVISION				10
TOTAL HOURS				45



1021235313	<b>Heavy Vehicle Engineering</b>	L	T	P	C
THEORY		3	0	0	3

**Suggested List of Students Activity:**

- Presentation/Seminars by students on any recent technological developments based on the course.

**Text book for Reference:**

1. Sean Bennett, Heavy Duty Truck Systems, Seventh Edition, Cengage, USA 2018.
2. Gus Wright, Owen C. Duffy Fundamentals of Medium/Heavy Duty Commercial Vehicle Systems, Second Edition, CDX Learning system, USA 2020.
3. Ulrich W.Seiffert, Hans Hermann Bracess, Handbook of Automotive Engineering, SAE International, USA 2005.

**Web-based/Online Resources:**

- NPTEL :: Engineering Design - NOC: Fundamentals of Automotive Systems  
<https://archive.nptel.ac.in/courses/107/106/107106088/>
- [www.sae.org](http://www.sae.org) -Society of Automotive Engineers

**END SEMESTER QUESTION PATTERN - THEORY EXAM**

**Duration: 3 Hrs.**

**Max. Marks: 100**

**Note:** Answer Ten questions by selecting two questions from each unit. Each question carries 10 marks each.

**Instruction to the Question Setters**

Four questions will be asked from every unit, students should write any two questions for 10 marks. The question may have two subdivisions only.



1021235314	<b>AUTOMOTIVE SAFETY SYSTEMS</b>	L	T	P	C
THEORY		3	0	0	3

### **INTRODUCTION**

In today's fast-paced world, safety features in vehicles have become more critical. It protects the occupants of the vehicle, safeguard pedestrians and other road users. Safety features are not just a luxury but also a necessity in today's vehicles. In recent years, a number of advances have been gradually introduced that have made it possible to build increasingly robust and reliable vehicle safety systems. It offers peace of mind to drivers and passengers alike and can save lives in the event of an accident. This course enables the students to know about the incorporation of different safety systems in vehicles and its functions. As a society, we should continue to demand and encourage the implementation of safety features in all vehicles to make our roads safer for everyone.

### **COURSE OBJECTIVES**

The objective of this course is to enable the student to

1. Know about the important terms in automotive safety systems.
2. Explore the safety tests for vehicles
3. Identify different safety equipments in vehicles
4. Classify various active safety systems.
5. Describe the major passive safety systems in vehicles.

### **COURSE OUTCOMES**

After successful completion of this course, the students can able to

- CO 1: Summarize the importance terms and standards in automotive safety.
- CO 2: Outline the major safety tests in vehicles
- CO 3: Demonstrate the different safety equipments in vehicles.
- CO 4: Explain the function and working active safety systems.
- CO 5: Illustrate the various passive safety system for vehicles



1021235314	<b>AUTOMOTIVE SAFETY SYSTEMS</b>	L	T	P	C
THEORY		3	0	0	3

**PREREQUISITES**

Knowledge of Automotive Engines , Power units and Transmission, Automotive Electrical and Electronics Systems, Sensors and Actuators.

**CO/PO Mapping**

CO/PO	PO1	PO2	PO3	PO4	PO5	PO6	PO7
<b>C01</b>	3	1	2	2	1	2	2
<b>C02</b>	3	2	2	2	2	2	2
<b>C03</b>	3	2	2	3	2	2	3
<b>C04</b>	3	1	2	3	2	2	3
<b>C05</b>	3	1	2	2	2	2	3

**Instructional Strategy:**

- Engage and Motivate: Instructors should actively engage students to boost their confidence.
- Real-World Relevance: Incorporate relatable, real-life examples and engineering applications to help students understand and appreciate course concepts.
- Interactive Learning: Utilize demonstrations and plan interactive student activities for an engaging learning experience.
- Application-Based Learning: Employ a theory-demonstrate-practice-activity strategy throughout the course to ensure outcome-driven learning and employability.
- Simulation and Real-World Practice: Conduct demonstrations and hands-on activities in a simulated environment, transitioning to real-world scenarios when possible.



1021235314	<b>AUTOMOTIVE SAFETY SYSTEMS</b>	L	T	P	C
THEORY		3	0	0	3

### Assessment Methodology

	Continuous Assessment (40 marks)				End Semester Examination (60 marks)
	CA1	CA2	CA3	CA4	
<b>Mode</b>	Written test (Two units)	Written test (Another Two units)	Quiz MCQ (Online / Offline)	Model Examination	Written Examination
<b>Duration</b>	2 Periods	2 Periods	1 Hour	3 Hours	3 Hours
<b>Exam Marks</b>	50	50	60	100	100
<b>Converted to</b>	15	15	5	20	60
<b>Marks</b>	15		5	20	60
<b>Tentative Schedule</b>	6th Week	12th Week	13-14th Week	16th Week	

**CA1 and CA2:** Assessment written test should be conducted for 50 Marks for two units. The marks scored will be converted to 15 Marks. Best of one will be considered for the internal assessment of 15 Marks.

CA1 and CA2, Assessment test should be conducted for two units as below.

Answer any five questions (5 X 10 Marks = 50 Marks).

Eight questions will be asked, students should write Five questions. Each unit Four questions can be asked. Each question may have subdivisions. Maximum two subdivisions shall be permitted.

**CA3:** 60 MCQ can be asked by covering the entire portion. It may be conducted by Online /Offline. The answer scripts of every student (online / offline) for this assessment should be kept for records and future verification. The marks scored should be converted to 5 marks for the internal assessment



1021235314	<b>AUTOMOTIVE SAFETY SYSTEMS</b>	L	T	P	C
THEORY		3	0	0	3

**CA4:** Model examination should be conducted as per the end-semester question pattern. The marks should be converted to 20 marks for the internal assessment.

**Question Pattern:**

Answer Ten questions by selecting two questions from each unit. Each question carries 10 marks each.

Four questions will be asked from every unit, students should write any two questions. The question may have two subdivisions only.

**Syllabus Contents**

UNIT I	INTRODUCTION TO SAFETY SYSTEMS	
	Objectives of automotive safety, Types of safety systems, Techniques for design of vehicle body for safety, Location of engine, concept of crumple zone, safety sandwich construction, Mandatory safety features of car in India, Safety regulation for electric vehicles, Bharat NCAP and Global NCAP	7
UNIT II	SAFETY TESTS IN VEHICLE	
	Types of impacts in road accidents, Crash design techniques for front structures, Lumped Mass Spring (LMS) models, Crashworthiness-Rear testing, side impact testing, Roll over crash tests, side and Frontal Pole Impact, Pedestrian Impact Behavior of specific body structures in crash testing, Photographic analysis of impact tests, Regulatory requirements for crash testing.	7
UNIT III	SAFETY EQUIPMENTS	
	Seat belt, Types of seat belt, regulations, automatic seat belt tightener system, collapsible steering column, tiltable steering wheel, Importance of bumper design for safety, Survival space requirements, restraints systems used automobiles.	7



1021235314	<b>AUTOMOTIVE SAFETY SYSTEMS</b>	L	T	P	C
THEORY		3	0	0	3

UNIT IV	ACTIVE SAFETY SYSTEMS			
Definition of active safety system, Terms in active safety-driving safety, conditional safety, perceptibility safety, operating safety, Active safety systems in vehicle-ABS, Electronic stability Control, Adaptive Cruise control, tyre pressure control system, Lane Departure Warning Tracking System, Blind spot detection, Night vision system, Drowsy driver detection and Warning Tracking System, Vehicle side alert, Driver monitoring, Road sign recognition, Automatic emergency braking.				7
UNIT V	PASSIVE SAFETY SYSTEMS			
Definition of passive safety system, Terms in passive safety-Exterior safety, interior safety. Passive safety systems in vehicle-Air bags operation concept, seat belt, Occupant sensing systems, Whiplash protection, Child safety systems, pedestrian safety, Engine immobilizer, Crash sensor system, Rollover protection bar, Breakaway engine.				7
TEST + REVISION				10
TOTAL				45

**Text book for Reference:**

1. Heinz Heisler, "Advanced vehicle technology", Butterworth Heineman, 2017.
2. Bosch - "Automotive Handbook" - 9th edition - SAE publication, 2022.
3. George A. Peters, "Automotive Vehicle Safety", 2003.

**Web-based/Online Resources:**



1021235314	<b>AUTOMOTIVE SAFETY SYSTEMS</b>	L	T	P	C
THEORY		3	0	0	3

**END SEMESTER QUESTION PATTERN - THEORY EXAM**

**Duration: 3 Hrs.**

**Max. Marks: 100**

**Note:** Answer Ten questions by selecting two questions from each unit. Each question carries 10 marks each.

**Instruction to the Question Setters**

Four questions will be asked from every unit, students should write any two questions for 10 marks. The question may have two subdivisions only.



1021235315	<b>ADVANCED AUTOMOTIVE SYSTEMS</b>	L	T	P	C
THEORY		3	0	0	3

### **INTRODUCTION**

Advancement in vehicle systems plays a predominant role in recent years. The course Advanced Automotive systems aimed to provide a solid background in the latest advancement in engine, transmission, suspension and steering systems. This course also helps the students to gain knowledge on comfort systems in vehicles and brief outline on autonomous vehicles. This course has been designed with considering the latest demand for skilled professionals required in automotive industries.

### **COURSE OBJECTIVES**

The objective of this course is to enable the student to

1. Acquire fundamental knowledge on latest advancement in engine systems.
2. Know the latest technology incorporated in transmission systems.
3. Understand the importance of steering and suspension systems
4. Familiarize with different comfort systems requirement in vehicles.
5. Enhance the knowledge on autonomous vehicles.

### **COURSE OUTCOMES**

After successful completion of this course, the students can able to

- CO 1: Outline the advancement in engine systems
- CO 2: Describe the basics and latest technologies incorporated in transmission systems
- CO 3: Explain the development of steering and suspension systems
- CO 4: Outline the various comfort systems in vehicles
- CO 5: Summarize the overview of Autonomous vehicles

### **PREREQUISITES**

Knowledge of the Basic Physics, Automotive Engines, Power units and Transmission, Automotive Electrical and Electronics Systems.



1021235315	<b>ADVANCED AUTOMOTIVE SYSTEMS</b>	L	T	P	C
THEORY		3	0	0	3

**CO/PO Mapping**

CO/PO	P01	P02	P03	P04	P05	P06	P07
C01	3	1	1	3	1	2	2
C02	3	1	1	3	1	2	2
C03	3	2	1	2	1	2	2
C04	3	2	1	2	1	2	2
C05	3	1	1	1	1	1	2

**Instructional Strategy:**

- Engage and Motivate: Instructors should actively engage students to boost their confidence.
- Real-World Relevance: Incorporate relatable, real-life examples and engineering applications to help students understand and appreciate course concepts.
- Interactive Learning: Utilize demonstrations and plan interactive student activities for an engaging learning experience.
- Application-Based Learning: Employ a theory-demonstrate-practice-activity strategy throughout the course to ensure outcome-driven learning and employability.
- Simulation and Real-World Practice: Conduct demonstrations and hands-on activities in a simulated environment, transitioning to real-world scenarios when possible.



1021235315	<b>ADVANCED AUTOMOTIVE SYSTEMS</b>	L	T	P	C
THEORY		3	0	0	3

### Assessment Methodology

	Continuous Assessment (40 marks)				End Semester Examination (60 marks)
	CA1	CA2	CA3	CA4	
<b>Mode</b>	Written test (Two units)	Written test (Another Two units)	Quiz MCQ (Online / Offline)	Model Examination	Written Examination
<b>Duration</b>	2 Periods	2 Periods	1 Hour	3 Hours	3 Hours
<b>Exam Marks</b>	50	50	60	100	100
<b>Converted to</b>	15	15	5	20	60
<b>Marks</b>	15		5	20	60
<b>Tentative Schedule</b>	6th Week	12th Week	13-14th Week	16th Week	

**CA1 and CA2:** Assessment written test should be conducted for 50 Marks for two units. The marks scored will be converted to 15 Marks. Best of one will be considered for the internal assessment of 15 Marks.

CA1 and CA2, Assessment test should be conducted for two units as below.

Answer any five questions (5 X 10 Marks = 50 Marks).

Eight questions will be asked, students should write Five questions. Each unit Four questions can be asked. Each question may have subdivisions. Maximum two subdivisions shall be permitted.

**CA3:** 60 MCQ can be asked by covering the entire portion. It may be conducted by Online /Offline. The answer scripts of every student (online / offline) for this assessment should be



1021235315	<b>ADVANCED AUTOMOTIVE SYSTEMS</b>	L	T	P	C
THEORY		3	0	0	3

kept for records and future verification. The marks scored should be converted to 5 marks for the internal assessment

**CA4:** Model examination should be conducted as per the end-semester question pattern. The marks should be converted to 20 marks for the internal assessment.

**Question Pattern:**

Answer Ten questions by selecting two questions from each unit. Each question carries 10 marks each.

Four questions will be asked from every unit, students should write any two questions. The question may have two subdivisions only.

**Syllabus Contents**

<b>UNIT I</b>	<b>ENGINE SYSTEMS</b>	
	Wankel Engine - Working - advantages - Limitations - Turbocharging - constant pressure turbocharging - pulse pressure turbocharging - working, advantages and limitations - downsizing of engine - variable compression ratio - Variable valve lift - Direct injection and stratified charge - Cylinder deactivation and variable valve timing - homogeneous charge compression ignition (HCCI). - Hybrid vehicles - Hydrogen combustion vehicles - Hydrogen fuel cell.	7
<b>UNIT II</b>	<b>TRANSMISSION SYSTEM</b>	
	Purpose of Gear box - Definition - Working of Automatic Transmission - Automatic manual transmission system - Dual clutch transmission - Continuous variable	7



1021235315	<b>ADVANCED AUTOMOTIVE SYSTEMS</b>	L	T	P	C
THEORY		3	0	0	3

transmission- Tiptronic transmission - Torque converter transmission - Overdrive - Viscous coupling - Four wheel drive system.		
<b>UNIT III</b>	<b>STEERING AND SUSPENSION SYSTEMS</b>	
Layout and working-advantages - Electronically Controlled Suspension Systems - Air Suspension Systems - hydro-elastic suspension - Steering Systems - Working of Adaptive steering, steer-by-wire, active steering, Torque vectoring, autonomous steering, and haptic steering.		7
<b>UNIT IV</b>	<b>VEHICLE COMFORT SYSTEMS</b>	
Mirror adjustment, central locking system , Garage door opening system, rain sensor system, environment information system, Collision warning system, causes of rear end collision, frontal object detection, rear vehicle object detection system, object detection system with braking system Interactions-Pre crash sensing, Hill assist, Occupant detection sensing, Rear detection systems		7
<b>UNIT V</b>	<b>AUTONOMOUS VEHICLES</b>	
Introduction - Levels of autonomy - Working of Autonomous vehicle - Lidar system - Radar sensors - Ultrasonic Sensors - Infrared Sensors - Central Computer - Global positioning systems – Wireless communication - Vehicle to vehicle (V2V) - vehicle to Infrastructure (V2I) - Application of Autonomous Vehicle - Advantages and Disadvantages of Autonomous Vehicles - Advanced driver assist system(ADAS).		7
TEST + REVISION		10
TOTAL HOURS		45



1021235315	<b>ADVANCED AUTOMOTIVE SYSTEMS</b>	L	T	P	C
THEORY		3	0	0	3

**Text book for Reference:**

1. Tom Denton, "Automobile electrical and electronic systems", 2011.
2. McGrath, Michael E., "Autonomous Vehicles: Opportunities, Strategies, and Challenges", Fifth Edition, 2024.
3. Jack Erjavec , Rob Thompson, "Automotive Technology: A Systems Approach", Delmar Cengage Learning; 7th edition, 2019.

**Web-based/Online Resources:**

**END SEMESTER QUESTION PATTERN - THEORY EXAM**

**Duration: 3 Hrs.**

**Max. Marks: 100**

**Note:** Answer Ten questions by selecting two questions from each unit. Each question carries 10 marks each.

**Instruction to the Question Setters**

Four questions will be asked from every unit, students should write any two questions for 10 marks. The question may have two subdivisions only.



1021235316	<b>ALTERNATIVE FUELS</b>	L	T	P	C
THEORY		3	0	0	3

### **Introduction**

"Alternative fuels" is a captivating field at the forefront of energy innovation, offering sustainable solutions to mitigate environmental impacts and reduce dependency on fossil fuels. This subject explores a diverse range of renewable resources and advanced technologies aimed at powering vehicles, industries, and homes while minimizing carbon emissions and other pollutants. From biofuels derived from organic materials like crops and algae to hydrogen and unconventional sources like waste materials, alternative fuels present a dynamic landscape of possibilities in the quest for a cleaner, more sustainable energy future. This multidisciplinary field encompasses aspects of chemistry, engineering, environmental science, economics, and policy, making it both intellectually stimulating and vital for addressing global energy challenges. Through research, development, and implementation, the study of alternative fuels offers promising avenues for creating a more resilient and environmentally conscious energy ecosystem.

### **Course Objectives**

- To present a problem oriented in depth knowledge of Alternate fuels.
- To address the underlying concepts and methods behind alternate fuels.

### **Course Outcomes:**

On successful completion of this course, the student will be able to

CO1: Understand about the Alcohol as fuel

CO2: Understand about the Bio diesel as fuel

CO3: Understand about the Hydrogen as fuel

CO4: Understand about the Bio gas and Natural gas as fuel

CO5: Understand about Vegetable oils and synthetic alternative fuels

### **Pre-requisites:**

Nil



1021235316	<b>ALTERNATIVE FUELS</b>	L	T	P	C
THEORY		3	0	0	3

**CO/PO Mapping**

CO / PO	P01	P02	P03	P04	P05	P06	P07
<b>C01</b>	2	-	1	-	3	-	1
<b>C02</b>	2	-	1	-	3	-	1
<b>C03</b>	2	-	1	-	3	-	1
<b>C04</b>	2	-	1	-	3	-	1
<b>C05</b>	2	-	1	-	3	-	1

*Legend: 3-High Correlation, 2-Medium Correlation, 1-Low Correlation*

**Instructional Strategy:**

Engage and Motivate: Instructors should actively engage students to increase their learning confidence.

Interactive learning: Arrange interactive student activities and make use of demonstrations to create a dynamic learning environment.



1021235316	<b>ALTERNATIVE FUELS</b>	L	T	P	C
THEORY		3	0	0	3

### Assessment Methodology

	Continuous Assessment (40 marks)				End Semester Examination (60 marks)
	CA1	CA2	CA3	CA4	
<b>Mode</b>	Written test (Two units)	Written test (Another Two units)	Quiz MCQ (Online / Offline)	Model Examination	Written Examination
<b>Duration</b>	2 Periods	2 Periods	1 Hour	3 Hours	3 Hours
<b>Exam Marks</b>	50	50	60	100	100
<b>Converted to</b>	15	15	5	20	60
<b>Marks</b>	15		5	20	60
<b>Tentative Schedule</b>	6th Week	12th Week	13-14th Week	16th Week	

**CA1 and CA2:** Assessment written test should be conducted for 50 Marks for two units. The marks scored will be converted to 15 Marks. Best of one will be considered for the internal assessment of 15 Marks.

CA1 and CA2, Assessment test should be conducted for two units as below.

Answer any five questions (5 X 10 Marks = 50 Marks).

Eight questions will be asked, students should write Five questions. Each unit Four questions can be asked. Each question may have subdivisions. Maximum two subdivisions shall be permitted.

**CA3:** 60 MCQ can be asked by covering the entire portion. It may be conducted by Online /Offline. The answer scripts of every student (online / offline) for this assessment should be



1021235316	<b>ALTERNATIVE FUELS</b>	L	T	P	C
THEORY		3	0	0	3

kept for records and future verification. The marks scored should be converted to 5 marks for the internal assessment

**CA4:** Model examination should be conducted as per the end-semester question pattern. The marks should be converted to 20 marks for the internal assessment.

**Question Pattern:**

Answer Ten questions by selecting two questions from each unit. Each question carries 10 marks each.

Four questions will be asked from every unit, students should write any two questions. The question may have two subdivisions only.

**Syllabus Contents**

<b>Unit I</b>	<b>ALCOHOL</b>	
	Introduction to alternative fuels - Need for alternative fuels - Availability of different alternative fuels for SI and CI engines. Alcohols as fuels – Properties – Sources and Production methods – Methods of using alcohols in SI and CI engines. Blending, Dual fuel operation, Surface ignition and oxygenated additives. Performance, combustion and emission characteristics in engines. Issues & limitations in alcohols.	7
<b>Unit II</b>	<b>BIO-DIESEL</b>	
	Base materials used for production of Biodiesel (Pongamia oil, Neem oil, Sunflower oil, Soybean oil, Mustard oil, Palm oil, Jatropha seeds). Production method of Biodiesel. Properties – Biodiesel Blends- Effect of Biodiesel on engine performances and Emissions.	7



1021235316	<b>ALTERNATIVE FUELS</b>	L	T	P	C
THEORY		3	0	0	3

<b>Unit III</b>	<b>HYDROGEN</b>			
Hydrogen - Properties, Sources and methods of Production of Hydrogen - Storage and Safety aspects - Methods of using hydrogen in SI and CI engines - Performance - Combustion - Emission characteristics in SI and CI engines. Fuel Cells: Concept of fuel cells based on usage of Hydrogen and Methanol. Power rating and performance. Heat dissipation.				7
<b>Unit IV</b>	<b>BIOGAS AND NATURAL GAS</b>			
BIO GAS: Properties and Production methods - Scrubbing of CO <sub>2</sub> and H <sub>2</sub> S from Biogas. Modification required - Performance - Combustion and Emission in SI & CI engines. NATURAL GAS: Properties and Production methods - Performance, Combustion and Emission characteristics in engines. Limitations in Gaseous fuels.				7
<b>Unit V</b>	<b>VEGETABLE OILS AND SYNTHETIC ALTERNATIVE FUELS</b>			
Various vegetable oils - Properties - Methods of using in engines - Blending, Preheating, Transesterification and Emulsification - Performance, combustion and emission Characteristics in diesel engines. Synthetic Alternative Fuels: Di-Methyl Ether (DME), P-Series fuels, Eco Friendly Plastic Fuels (EPF) - Advantages of Synthetic Alternative Fuels.				7
TEST + REVISION				10
Total				45

**Suggested List of Students Activity:**

Students will give presentations or hold seminars on any current technological developments related to the subject.

Periodic class quizzes are given on a weekly / fortnightly basis depending on the course.



1021235316	<b>ALTERNATIVE FUELS</b>	L	T	P	C
THEORY		3	0	0	3

**Text book for Reference:**

1. Alternate Fuels by Dr. S. Thipse, Jaico Publications
2. "Automotive Emission Control" by Crouse, AND Anglin – McGraw Hill.
3. "Alternative Fuels Guidebook" by Bechtold R.
4. SAE Paper nos. 840367, 841333, 841334.
5. "Internal Combustion Engines" by Ganeshan – Tata McGraw Hill.
6. "Internal Combustion Engines" by Heywood John.
7. The properties and performance of modern alternative fuels" – SAE Paper no. 841210.

**Web-based/Online Resources:**

**END SEMESTER QUESTION PATTERN - THEORY EXAM**

**Duration: 3 Hrs.**

**Max. Marks: 100**

**Note:** Answer Ten questions by selecting two questions from each unit. Each question carries 10 marks each.

**Instruction to the Question Setters**

Four questions will be asked from every unit, students should write any two questions for 10 marks. The question may have two subdivisions only.



1021235317	<b>ALTERNATIVE ENERGY SOURCES</b>	L	T	P	C
THEORY		3	0	0	3

**Introduction:**

The study of alternative energy systems examines the design, implementation, and optimization of sustainable energy technologies. It encompasses a wide range of disciplines, including engineering, physics, chemistry, environmental science, economics, and policy.

This subject is crucial in the context of global challenges such as climate change, energy security, and economic sustainability. By diversifying energy sources and reducing reliance on fossil fuels, alternative energy systems offer the potential to create a more resilient and environmentally friendly energy infrastructure.

Overall, alternative energy systems represent a promising pathway towards a more sustainable and prosperous future, where clean and renewable energy plays a central role in powering societies while preserving the planet for future generations.

**Course objectives**

- To understand energy scenario, energy sources and their utilization.
- To explore society’s present needs and future energy demands.
- To Study the principles of renewable energy conversion systems.
- To exposed to energy conservation methods.

**Course Outcomes:**

On successful completion of this course, the student will be able to

CO1: Understand the principles and descriptions about renewable energy sources.

CO2: Understand about Solar energy and solar Electric power generation.

CO3: Understand about the Wind energy and Biomass energy

CO4: Understand about the Tidal energy and Ocean Thermal energy conversion.

CO5: Understand about Green energy.

**Pre-requisites:**

Knowledge of basic Science



1021235317	<b>ALTERNATIVE ENERGY SOURCES</b>	L	T	P	C
THEORY		3	0	0	3

### CO/PO Mapping

CO / PO	P01	P02	P03	P04	P05	P06	P07
<b>C01</b>	2	1	2	-	3	-	2
<b>C02</b>	2	1	2	-	3	-	2
<b>C03</b>	2	1	2	-	3	-	2
<b>C04</b>	2	1	2	-	3	-	2
<b>C05</b>	2	1	2	-	3	-	2

*Legend: 3-High Correlation, 2-Medium Correlation, 1-Low Correlation*

### Instructional Strategy:

- Engage and Motivate: Instructors should actively engage students to boost their confidence.
- Real-World Relevance: Incorporate relatable, real-life examples and engineering applications to help students understand and appreciate course concepts.
- Interactive Learning: Utilize demonstrations and plan interactive student activities for an engaging learning experience.
- Application-Based Learning: Employ a theory-demonstrate-practice-activity strategy throughout the course to ensure outcome-driven learning and employability.
- Simulation and Real-World Practice: Conduct demonstrations and hands-on activities in a simulated environment, transitioning to real-world scenarios when possible.



1021235317	<b>ALTERNATIVE ENERGY SOURCES</b>	L	T	P	C
THEORY		3	0	0	3

### Assessment Methodology

	Continuous Assessment (40 marks)				End Semester Examination (60 marks)
	CA1	CA2	CA3	CA4	
<b>Mode</b>	Written test (Two units)	Written test (Another Two units)	Quiz MCQ (Online / Offline)	Model Examination	Written Examination
<b>Duration</b>	2 Periods	2 Periods	1 Hour	3 Hours	3 Hours
<b>Exam Marks</b>	50	50	60	100	100
<b>Converted to</b>	15	15	5	20	60
<b>Marks</b>	15		5	20	60
<b>Tentative Schedule</b>	6th Week	12th Week	13-14th Week	16th Week	

**CA1 and CA2:** Assessment written test should be conducted for 50 Marks for two units. The marks scored will be converted to 15 Marks. Best of one will be considered for the internal assessment of 15 Marks.

CA1 and CA2, Assessment test should be conducted for two units as below.

Answer any five questions (5 X 10 Marks = 50 Marks).

Eight questions will be asked, students should write Five questions. Each unit Four questions can be asked. Each question may have subdivisions. Maximum two subdivisions shall be permitted.

**CA3:** 60 MCQ can be asked by covering the entire portion. It may be conducted by Online /Offline. The answer scripts of every student (online / offline) for this assessment should be kept for records and future verification. The marks scored should be converted to 5 marks for the internal assessment



1021235317	<b>ALTERNATIVE ENERGY SOURCES</b>	L	T	P	C
THEORY		3	0	0	3

**CA4:** Model examination should be conducted as per the end-semester question pattern. The marks should be converted to 20 marks for the internal assessment.

**Question Pattern:**

Answer Ten questions by selecting two questions from each unit. Each question carries 10 marks each.

Four questions will be asked from every unit, students should write any two questions. The question may have two subdivisions only.

**Syllabus Contents**

<b>Unit I</b>	<b>INTRODUCTION</b>	
	<b>Introduction:</b> Principles of Renewable energy; Energy and sustainable development, fundamentals and social implications. worldwide renewable energy availability and renewable energy availability in India, brief descriptions on Solar energy, Wind energy, Tidal energy, Wave energy, Ocean Thermal energy, Biomass energy, Geothermal energy, Oil shale. Introduction to Internet of energy (IOE).	7
<b>Unit II</b>	<b>SOLAR ENERGY</b>	
	<b>Solar Energy:</b> Fundamentals -Solar Radiation - Estimation of solar radiation on horizontal and inclined surfaces - Solar radiation Measurements- Pyrheliometers, Pyrometer, Sunshine Recorder. Solar Thermal systems: Flat plate collector; Solar distillation; Solar pond electric power plant. <b>Solar Electric Power Generation-</b> Principle of Solar cell, Photovoltaic system for electric power generation, advantages, Disadvantages and applications of solar photovoltaic system.	7
<b>Unit III</b>	<b>WIND ENERGY AND BIOMASS ENERGY</b>	
	<b>Wind Energy:</b> Properties of wind - Availability of wind energy in India, Wind velocity and power from wind - Major problems associated with wind power, Basic components of Wind	7



1021235317	<b>ALTERNATIVE ENERGY SOURCES</b>	L	T	P	C
THEORY		3	0	0	3

Energy Conversion System (WECS) - Classification of WECS- Horizontal axis- single, double and multi blade system. Vertical axis- Savonius and Darrieus types. <b>Biomass Energy:</b> Introduction - Photosynthesis Process - Biofuels; Biomass Resources - Biomass conversion technologies-fixed dome; Urban waste to Energy Conversion - Biomass gasification (Downdraft).		
<b>Unit IV</b>	<b>TIDAL ENERGY</b>	
<b>Tidal Power:</b> Tides and waves as energy suppliers and their mechanics - Fundamental characteristics of Tidal power, harnessing Tidal Energy, advantages and limitations. <b>Ocean Thermal Energy Conversion:</b> Principle of working - OTEC power stations in the world - Problems associated with OTEC.		7
<b>Unit V</b>	<b>GREEN ENERGY</b>	
<b>Green Energy:</b> Introduction - Fuel cells - Classification of fuel cells – H <sub>2</sub> ; Operating principles, Zero energy Concepts. Benefits of hydrogen energy - Hydrogen production technologies (Electrolysis method only), Hydrogen Energy storage - Applications of hydrogen energy - Problem associated with hydrogen energy.		7
TEST + REVISION		10
TOTAL HOURS		45

**Suggested List of Students Activity:**

Students will give presentations or hold seminars on any current technological developments related to the subject.

Periodic class quizzes are given on a weekly / fortnightly basis depending on the course.

**Text book for Reference:**

1. Non Conventional Energy sources, G D Rai, Khanna Publication, Fourth Edition,
2. Energy Technology, S.Rao and Dr. B.B. Parulekar, Khanna Publication.
3. Solarenergy, Subhas P Sukhatme, Tata McGraw Hill, 2ndEdition,1996.
4. Principles of Energy conversion, A. W. Culp Jr., McGraw Hill, 1996
5. Non-Conventional Energy Resources, Shobh Nath Singh, Pearson, 2018



1021235317	<b>ALTERNATIVE ENERGY SOURCES</b>	L	T	P	C
THEORY		3	0	0	3

**Web-based/Online Resources:**

1. [https://onlinecourses.nptel.ac.in/noc18\\_ge09/preview](https://onlinecourses.nptel.ac.in/noc18_ge09/preview)

**END SEMESTER QUESTION PATTERN - THEORY EXAM**

**Duration: 3 Hrs.**

**Max. Marks: 100**

**Note:** Answer Ten questions by selecting two questions from each unit. Each question carries 10 marks each.

**Instruction to the Question Setters**

Four questions will be asked from every unit, students should write any two questions for 10 marks. The question may have two subdivisions only.



1021235318	<b>SPECIAL PURPOSE VEHICLES</b>	L	T	P	C
THEORY		3	0	0	3

**Introduction:**

Special purpose vehicles do not operate on the main road or regular road, these types of vehicles are also known as OFF-road vehicles. The areas like Earth moving equipment, constructional equipment, farm equipment, industrial vehicle, military and combat vehicle.

Earth moving machines are used primarily for moving earth material. They are also used for removing debris, laying down foundations, digging holes and trenches and grading rock and soil.

Modern farm machinery has upgraded the agricultural industry for the best.

Industrial Vehicle - A two or four -wheel drive type vehicle, or track vehicle, of more than 20 engine horsepower.

Most military vehicles require off-road capabilities and/or vehicle armor, making them heavy.

**Course Objectives:**

- Enhance the knowledge of the students about the various equipment used in earth moving applications.
- Understand the construction and working of the vehicle for constructional application.
- Describe the working nature of farm equipment based on their application.
- Discriminate the various industrial vehicles based on the purpose.
- To acquire the knowledge on the functioning of military vehicles.

**Course Outcomes:**

On successful completion of this course, the student will be able to

CO1: Demonstrate their understanding about the operation of the various special purpose vehicles.

CO2: Understand the construction layout of earth moving equipments.

CO3: Have the ability to apply the knowledge to design a new concept for construction application.

CO4: Demonstrate their skill in developing modern techniques for future farming vehicles.

CO5: Distinguish the various military vehicles and infer their particular technology.



1021235318	<b>SPECIAL PURPOSE VEHICLES</b>	L	T	P	C
THEORY		3	0	0	3

**Pre-requisites:**

Knowledge of basic Automobile Engineering/ Technology.

**CO/PO Mapping**

CO / PO	P01	P02	P03	P04	P05	P06	P07
<b>C01</b>	2	1	2	1	1	2	1
<b>C02</b>	2	1	2	2	2	1	2
<b>C03</b>	2	2	2	1	1	1	2
<b>C04</b>	2	2	2	1	2	1	2
<b>C05</b>	2	2	2	1	2	1	2

*Legend: 3-High Correlation, 2-Medium Correlation, 1-Low Correlation*

**Instructional Strategy:**

- It is advised that teachers take steps to create interest, attention and boost their learning confidence.
- The demonstration can make the subject exciting and foster in the students a scientific mindset. Student activities should be planned on all the topics.
- Teachers can spark meaningful discussion in classrooms by encouraging students to ask open-ended questions, re-state remarks in more scientific language, develop and use models to construct explanations.
- An effective method is for a teacher to propose and discuss a question in the classroom, then for learners to explore that question on a museum visit or field trip, collecting photos or notes as evidence, then share their findings back in the class to produce individual or group answers.



1021235318	<b>SPECIAL PURPOSE VEHICLES</b>	L	T	P	C
THEORY		3	0	0	3

### Assessment Methodology

	Continuous Assessment (40 marks)				End Semester Examination (60 marks)
	CA1	CA2	CA3	CA4	
<b>Mode</b>	Written test (Two units)	Written test (Another Two units)	Quiz MCQ (Online / Offline)	Model Examination	Written Examination
<b>Duration</b>	2 Periods	2 Periods	1 Hour	3 Hours	3 Hours
<b>Exam Marks</b>	50	50	60	100	100
<b>Converted to</b>	15	15	5	20	60
<b>Marks</b>	15		5	20	60
<b>Tentative Schedule</b>	6th Week	12th Week	13-14th Week	16th Week	

**CA1 and CA2:** Assessment written test should be conducted for 50 Marks for two units. The marks scored will be converted to 15 Marks. Best of one will be considered for the internal assessment of 15 Marks.

CA1 and CA2, Assessment test should be conducted for two units as below.

Answer any five questions (5 X 10 Marks = 50 Marks).

Eight questions will be asked, students should write Five questions. Each unit Four questions can be asked. Each question may have subdivisions. Maximum two subdivisions shall be permitted.

**CA3:** 60 MCQ can be asked by covering the entire portion. It may be conducted by Online /Offline. The answer scripts of every student (online / offline) for this assessment should be kept for records and future verification. The marks scored should be converted to 5 marks for the internal assessment



1021235318	<b>SPECIAL PURPOSE VEHICLES</b>	L	T	P	C
THEORY		3	0	0	3

**CA4:** Model examination should be conducted as per the end-semester question pattern. The marks should be converted to 20 marks for the internal assessment.

**Question Pattern:**

Answer Ten questions by selecting two questions from each unit. Each question carries 10 marks each.

Four questions will be asked from every unit, students should write any two questions. The question may have two subdivisions only.

**Syllabus Contents**

<b>Unit I</b>	<b>EARTH MOVING EQUIPMENTS</b>	
	Construction layout, capacity and applications of dumpers, articulated haulers, front-end loaders, backhoe loaders, bulldozers, scrappers, motor graders, skid steer loaders, excavators, hydraulic shovels, bucket conveyors, surface miners –high wall Miners. Selection criteria of prime mover for dumpers.	7
<b>Unit II</b>	<b>CONSTRUCTIONAL EQUIPMENTS</b>	
	Construction layout, capacity and applications of cranes – types , Articulated Trucks, concrete ready mixer, trenchers, Asphalt Pavers, road reclaimers, Compactors – types, draglines, drillers, borewell machine.	7
<b>Unit III</b>	<b>FARM EQUIPMENTS</b>	
	Classification of tractors – Main components of tractor. Working attachment of tractors – Auxiliary equipment -- Top lifting harvesters. General description, working, specification and functions paddy harvesting machines, Sugarcane harvesting, feller bunchers, forest machines.	7



1021235318	<b>SPECIAL PURPOSE VEHICLES</b>	L	T	P	C
THEORY		3	0	0	3

<b>Unit IV</b>	<b>INDUSTRIAL VEHICLES</b>			
Constructional features, capacity and working of forklifts, Utility vehicles, towing vehicles, man-lift chassis, scissor lift trucks, material handlers, reclaimers, Street sweepers.				7
<b>Unit V</b>	<b>MILITARY AND COMBAT VEHICLES</b>			
Special features and constructional details of Main Battle tank, gun carriers, transport vehicles, Armoured vehicle-launched bridge, amphibious bridging vehicle, communication vehicles.				7
Test + Revision				10
Total				45

**Text book for Reference:**

1. Abrosimov. K. Bran berg.A. andKatayer.K.," Road making Machinery ", MIR Publishers, Moscow, 1971.
2. Rodichev and G.Rodicheva,Tractor and Automobiles, MIR Publishers,1987.
3. Kolchin A. and V.Demidov, Design of Automotive Engines for Tractor, MIR Publishers,1972.
4. Peurifoy R.L "Construction Planning, Equipment and Methods", Tata McGraw-Hill, New Delhi, 2002.
5. Wong J "Terramechanics and Off-Road Vehicle Engineering", Butterworth Heinemann, 2009.

**Web-based/Online Resources:**

- <https://www.holtags.com/types-of-farm-equipment-and-their-uses>
- <https://dir.indiamart.com/impcat/forklift-trucks.html>
- [https://en.wikipedia.org/wiki/Combat\\_vehicle](https://en.wikipedia.org/wiki/Combat_vehicle)
- [https://www.academia.edu/30711395/EARTH\\_MOVING\\_EQUIPMENT](https://www.academia.edu/30711395/EARTH_MOVING_EQUIPMENT)
- <https://logistikknowhow.com/en/material-flow-and-transport-en/industrial-trucks-definition>



1021235318	<b>SPECIAL PURPOSE VEHICLES</b>	L	T	P	C
THEORY		3	0	0	3

**END SEMESTER QUESTION PATTERN - THEORY EXAM**

**Duration: 3 Hrs.**

**Max. Marks: 100**

**Note:** Answer Ten questions by selecting two questions from each unit. Each question carries 10 marks each.

**Instruction to the Question Setters**

Four questions will be asked from every unit, students should write any two questions for 10 marks. The question may have two subdivisions only.



1021235440	<b>Automobile Servicing Practical</b>	L	T	P	C
PRACTICUM		1	0	4	3

**Introduction:**

Automobiles are an integral part of modern transportation, and their proper maintenance and servicing are crucial for ensuring safety, reliability, and longevity. The Automobile Servicing Practical course is designed to provide diploma students with hands-on training and practical experience in various aspects of automotive servicing and maintenance.

This course aims to equip students with the necessary skills and knowledge to perform routine maintenance tasks, diagnose and troubleshoot common automotive issues, and carry out repairs and servicing procedures in accordance with industry standards and best practices. Students will gain practical experience working on various automotive systems, including engines, transmissions, brakes, suspension, electrical, and other related components.

Through a combination of theoretical instruction and hands-on practical sessions, students will learn to use specialized tools and equipment, follow safety protocols, and develop proficiency in performing tasks such as oil changes, brake inspections, tire rotations, and other essential maintenance procedures.

Upon successful completion of this course, students will be well-prepared to pursue careers in the automotive service industry, working in dealerships, independent repair shops, or even starting their own automotive servicing businesses. The practical skills and knowledge acquired in this course will lay a solid foundation for further professional development and continuing education in the field of automotive technology.

**Course Objectives:**

1. Develop hands-on skills in performing routine maintenance tasks and repairs on various automotive systems, including engine, transmission, brakes, suspension, and electrical systems.
2. Gain proficiency in using specialized tools, diagnostic equipment, and following safety protocols in an automotive service environment.
3. Acquire the ability to accurately diagnose and troubleshoot common automotive issues through critical thinking and problem-solving skills.



1021235440	<b>Automobile Servicing Practical</b>	L	T	P	C
PRACTICUM		1	0	4	3

4. Learn to interpret and follow manufacturer specifications, service manuals, and technical documentation for proper automotive servicing and repairs.
5. Develop professional attitudes, record-keeping practices, and communication skills essential for success in the automotive service industry.

**Course Outcomes:**

Upon successful completion of this course, students will be able to,

C01: Perform routine maintenance tasks and repairs on various automotive systems.

C02: Utilize specialized tools and diagnostic equipment effectively to diagnose and troubleshoot common automotive issues.

C03: Disassemble, inspect, and reassemble automotive components and systems.

C04: Interpret diagnostic codes, service manuals, and technical documentation to identify and resolve automotive problems accurately.

C05: Demonstrate effective communication skills by accurately explaining automotive issues, recommending appropriate repairs or maintenance, and maintaining clear and concise service records.

**Pre-requisites:**

1. Completion of an introductory Automotive Technology course, covering the fundamentals of automotive systems and components.
2. Basic understanding of automotive engines, transmissions, brakes, suspension, and electrical/electronic systems.
3. Familiarity with common automotive service tools and equipment, such as hand tools, jacks, diagnostic scan tools, and multimeters.
4. Knowledge of automotive safety practices, including proper use of personal protective equipment (PPE), safe lifting techniques, and hazardous material handling procedures.



1021235440	<b>Automobile Servicing Practical</b>	L	T	P	C
PRACTICUM		1	0	4	3

**CO/PO Mapping:**

CO / PO	P01	P02	P03	P04	P05	P06	P07
<b>C01</b>	3	3	1	1	1		
<b>C02</b>	3	2	2	3	1		
<b>C03</b>	3	2	1	2	3	3	
<b>C04</b>	3	2	1	2	1		3
<b>C05</b>	3	1	1	2	1	2	2

Legend: 3-High Correlation, 2-Medium Correlation, 1-Low Correlation

**Instructional Strategy:**

1. Begin with classroom lectures and discussions to introduce students to the fundamental concepts and principles .
2. Use visual aids such as diagrams, illustrations, and multimedia presentations to enhance understanding of various automotive systems and their functions.
3. Provide hands-on demonstrations of basic servicing tasks and the use of specialized tools and equipment.
4. Emphasize the importance of safety in the automotive service environment. Conduct comprehensive safety training sessions covering personal protective equipment (PPE), safe lifting techniques, hazardous material handling, and shop safety protocols.
5. Ensure that students understand and adhere to all safety guidelines and regulations.
6. Divide students into smaller groups for practical demonstrations of more complex servicing tasks.
7. Provide ample opportunities for students to practice the demonstrated servicing tasks under the supervision of instructors.
8. Incorporate simulation software or virtual reality (VR) training modules to supplement hands-on practice.



1021235440	<b>Automobile Servicing Practical</b>	L	T	P	C
PRACTICUM		1	0	4	3

9. Encourage peer learning and collaboration by having students work in teams on specific projects or servicing tasks.
10. Arrange field trips or industry visits to automotive service centres, dealerships, or repair shops to expose students to real-world environments and practices.
11. Invite guest speakers or industry professionals to share their experiences and insights with students.

**Assessment Methodology:**

	Continuous Assessment (40 marks)				End Semester Examination (60 marks)
	CA1	CA2	CA3	CA4	
<b>Mode</b>	Practical Test	Practical Test	Written Test Theory	Practical Test	Practical Examination
<b>Portion</b>	Cycle I Exercises	Cycle II Exercises	All Units	All Exercises	All Exercises
<b>Duration</b>	2 Periods	2 Periods	3 Hours	3 Hours	3 hours
<b>Exam Marks</b>	60	60	100	100	100
<b>Converted to Marks</b>	10	10	15	15	60
<b>Marks</b>	10		15	15	60
<b>Tentative Schedule</b>	7th Week	14th Week	15th Week	16th Week	

Note:

- **CA1 and CA2:** All the exercises/experiments should be completed as per the portions above and kept for the practical test. The students shall be permitted to select any one by lot for the test. The practical test should be conducted as per the scheme of



1021235440	<b>Automobile Servicing Practical</b>	L	T	P	C
PRACTICUM		1	0	4	3

evaluation as below. The marks awarded shall be converted to 10 Marks for each assessment test. Best of one will be considered for the internal assessment of 10 Marks.

Practical documents should be maintained for every exercise / experiment immediately after completion of the practice. The practical document should be submitted for the practical test. The same should be evaluated for 10 Marks for each exercise/experiment. The total marks awarded should be converted to 10 Marks for the practical test as per the scheme of evaluation as below.

**The details of the practical documents are to be prepared as per the instructions below.**

Each exercise / experiment procedure, observation and calculations should be completed on the day of practice. The same shall be evaluated for 10 marks on the day or the next day of practice before the commencement of the next exercise.

This documentation can be carried out in a separate notebook or a printed manual or a file with documents. The observation, reading, calculations, report, graphs and results should be written by the student manually in the practical documents.

The evaluated practical document should be submitted for the Practical Test. The marks scored by the students should be converted to 10 marks. The same should be included as per the allocation in the practical test.

The detailed dates of the practices and its evaluations should be maintained in the course logbook. The log book and the practical documents should be submitted for the verification by the Flying Squad and DOTE Official.



1021235440	<b>Automobile Servicing Practical</b>	L	T	P	C
PRACTICUM		1	0	4	3

### SCHEME OF EVALUATION

PART	DESCRIPTION	MARKS
A	Aim & Tools Required	10
B	Procedure / Observation / Dismantle / Assemble	20
C	Report / Troubleshooting	20
TOTAL		50
D	Practical Documents (As per the portions)	10
		60

**Cycle I:** 1, 2, 3, 4, 5 and 6

**Cycle II:** 7, 8, 9, 10, 11 and 12.

- **CA 3:** Written Test for complete theory portions should be conducted for 100 Marks as per the question pattern below. The marks scored will be converted to 15 Marks for internal assessment.

#### Question pattern – Written Test Theory

Description		Marks	
Part – A	30 MCQ from the complete theory portions	30 X 1 Mark	30 Marks
Part – B	Seven Questions to be answered out of 10 Questions.	7 X 10 Marks	70 Marks
TOTAL			100 Marks

- **CA 4:** All the exercises/experiments should be completed and kept for the practical test. The students shall be permitted to select any one by lot for the test. The practical test should be conducted as per the scheme of evaluation below. After completion of all the exercises, the practical test should be conducted as per the End Semester Examination



1021235440	<b>Automobile Servicing Practical</b>	L	T	P	C
PRACTICUM		1	0	4	3

question pattern scheme of evaluation. The marks awarded should be converted to 15 Marks for the internal assessment.

### SCHEME OF EVALUATION

#### Model Practical Examination and End Semester Examination - Practical Exam

PART	DESCRIPTION	MARKS
A	Aim & Tools Required	10
B	Procedure / Observation / Dismantle / Assemble	20
C	Report / Troubleshooting	20
D	Output / Result	10
E	Written Test (Theory Portions only)	30
F	Viva Voce	10
TOTAL		100

**Note:** For the written test 30 MCQ shall be asked from the theory portions.

#### **Theory Portion - Chapter I**

<p>Ignition System: Overview of the Ignition System - Spark Plugs - Function. Ignition Coils - Function. weak spark. Distributor Caps - Function.</p> <p>Cooling System: Overview of the Cooling System - Purpose - Radiator, water pump, thermostat, coolant. Radiator - Function - Water Pump - Function. Thermostat - Function.</p> <p>Lubrication System - Overview of the Lubrication System - Purpose - Key Components: Oil pump, oil filter, oil pan, lubrication passages. Oil Pump - Function - Oil Filter.</p>	7
--	---



1021235440	<b>Automobile Servicing Practical</b>	L	T	P	C
PRACTICUM		1	0	4	3

<p>Fuel System - Overview of the Fuel System - Purpose - Key Components: Fuel pump, fuel injectors (MPFI and CRDI), fuel pressure regulator. Fuel Pump - Function - Fuel Injection Systems - Multi-Point Fuel Injection - Common Rail Direct Injection.</p> <p>Braking System - Overview of the Braking System - Purpose - Drum brakes, disc brakes, ABS (Anti-lock Braking System) - Function.</p> <p>Clutch and Gearbox - Overview of the Clutch System - Purpose - Key Components: Clutch disc, pressure plate, release bearing, hydraulic components. Common Clutch Issues - Slippage, difficulty engaging gears, pedal problems.</p> <p>Overview of the Gearbox - Purpose - Common Gearbox Issues: gear slipping, shifting problems, leaks, noise.</p>	
<p><b>Practical Exercises</b></p> <p><b>Exercise 1:</b> Ignition System: Identify and troubleshoot issues related to the ignition system components, such as spark plugs, ignition coils, distributor caps, and wiring. Perform diagnostic tests to isolate and rectify problems affecting the ignition system's performance.</p> <p><b>Exercise 2:</b> Cooling System: Diagnose and troubleshoot cooling system issues, including overheating, leaks, and problems with the water pump, thermostat, and radiator. Conduct tests and inspections to identify and resolve cooling system faults. Check and identify the trouble shoots in the lubricating system.</p> <p><b>Exercise 3:</b> Lubrication System: Identify and troubleshoot issues related to the engine's lubrication system, such as oil leaks, low oil pressure, and problems with the oil pump or oil filter. Perform diagnostic procedures to pinpoint and rectify lubrication system malfunctions.</p>	30



1021235440	<b>Automobile Servicing Practical</b>	L	T	P	C
PRACTICUM		1	0	4	3

<p><b>Exercise 4: Fuel System CRDI:</b> Troubleshoot issues in the fuel delivery system, including the fuel pump, Common Rail Direct Injection (CRDI) systems. Diagnose and rectify problems related to fuel supply, pressure, and injection components.</p> <p><b>Exercise 5: Fuel System - MPFI:</b> Troubleshoot issues in the fuel delivery system, including the fuel pump, Multi-Point Fuel Injection (MPFI) systems. Diagnose and rectify problems related to fuel supply, pressure, and injection components.</p> <p><b>Exercise 6: Braking System:</b> Identify and troubleshoot issues in the drum, disc, and Anti-lock Braking System (ABS) of a four-wheeler vehicle. Diagnose and resolve problems related to brake fluid, brake pads, calipers, rotors, and ABS components.</p> <p><b>Exercise 7: Clutch and Gearbox:</b> Troubleshoot issues related to the clutch system, including clutch slippage, clutch pedal problems, and hydraulic components. Identify and rectify problems in the gearbox, such as gear shifting issues, leaks, and transmission component malfunctions.</p>	
<b>Theory Portion - Chapter II</b>	
<p>Introduction to Automobile Servicing - overview of vehicle systems and components - Importance of regular maintenance and servicing - Safety precautions in automotive workshops</p> <p>Wheel Balancing - Principles of wheel balancing - Types of wheel imbalance: static and dynamic - Effects of imbalanced wheels on vehicle performance and safety. Wheel balancing machines: types and operation - Types of wheel weights and their application - Proper techniques for adding weights</p>	8



1021235440	<b>Automobile Servicing Practical</b>	L	T	P	C
PRACTICUM		1	0	4	3

<p>Suspension System - Functions of the suspension system - Types of suspension systems: dependent and independent - Major components: springs, shock absorbers, struts, control arms, bushings - Common suspension problems and their symptoms - Inspection techniques for suspension components - Alignment basics: camber, caster, and toe.</p> <p>Drivetrain Components - Propeller Shaft - Function and construction of propeller shafts - Types of joints: universal joints and constant velocity (CV) joints - Common issues with propeller shafts - Inspection procedures for propeller shafts</p> <p>Differential Unit - Purpose and function of the differential - Types of differentials: open, limited-slip, locking - Differential fluid types and importance - Common differential problems and symptoms - Inspection and maintenance procedures</p> <p>Front and Rear Axles - Types of axles: live axle and dead axle - Components of axle assemblies - Common axle problems: worn bearings, leaking seals, bent shafts - Inspection techniques for axle components</p> <p>Electrical System - Basic automotive electrical theory - Major components of the vehicle electrical system - Reading and interpreting wiring diagrams - Common electrical issues in vehicles - Use of multimeters and other diagnostic tools - Safety precautions when working with electrical systems - Fuse and relay testing procedures - Battery testing and maintenance. Engine Performance Diagnostics - OBD-II System - Introduction to On-Board Diagnostics (OBD-II) - OBD-II trouble codes and their meanings - Using OBD-II scanners for diagnostics</p>	
<p><b>Practical Exercises</b></p> <p><b>Exercise 8:</b> Wheel Balancing:</p> <p>Remove a wheel from the vehicle and mount it on a wheel balancing machine.</p> <p>Perform wheel balancing by adding the required weights to the wheel to ensure proper balance and minimize vibrations.</p>	20



1021235440	<b>Automobile Servicing Practical</b>	L	T	P	C
PRACTICUM		1	0	4	3

<p><b>Exercise 9:</b> Suspension System Inspection: Conduct a thorough inspection of the suspension system components, such as shocks, struts, springs, control arms, and bushings. Identify any signs of wear, damage, or improper alignment in the suspension system.</p> <p><b>Exercise 10:</b> Propeller Shaft and Differential Unit Inspection: Inspect the propeller shaft for proper alignment, wear, or damage. Check the differential unit for leaks, fluid level, and any signs of wear or damage.</p> <p><b>Exercise 11:</b> Front and Rear Axle Inspection: Inspect the front and rear axle assemblies, including bearings, seals, and axle shafts. Identify any signs of wear, leaks, or damage in the axle components.</p> <p><b>Exercise 12:</b> Electrical System Troubleshooting: Troubleshoot and identify issues in the vehicle's complete electrical system, including wiring, fuses, relays, and electrical components. Perform diagnostic tests and use appropriate tools to isolate and rectify electrical system faults.</p>	
Test + Revision	10
Total	75

**Suggested List of Students Activity:**

- Automotive System Disassembly and Reassembly
- Routine Maintenance Task.
- Electrical System Diagnosis and Repair.
- Engine Performance Diagnosis and Tuning.
- Professional Development and Industry Exposure.

**Text book for Reference:**

1. "Automotive Service: Inspection, Maintenance, Repair" by Tim Gilles
2. "Automotive Technology: Principles, Diagnosis, and Service" by James D. Halderman
3. "Auto Fundamentals" by Chris Johanson, Martin T. Stockel, and Martin W. Stockel



1021235440	<b>Automobile Servicing Practical</b>	L	T	P	C
PRACTICUM		1	0	4	3

4. Automobile Engineering Vol 1 & Vol 2 by Kirpal Singh
5. "Automotive Maintenance and Troubleshooting" by Mike DeVore
6. "Automotive Technician Certification Test Preparation Manual" by Don Knowles
7. "Automotive Brake Systems" by James D. Halderman
8. "Automotive Electrical and Electronic Systems" by James D. Halderman
9. "Automotive Engines: Theory and Servicing" by James D. Halderman
10. "Automotive Suspension and Steering Systems" by James D. Halderman
11. "Automotive Service: Inspection, Maintenance, Repair" by Tim Gilles (Instructor's Resource Manual)



1021235440	<b>Automobile Servicing Practical</b>	L	T	P	C
PRACTICUM		1	0	4	3

**Equipment / Facilities required to conduct the Practical Course.**

Sl. No.	Machinery's / Equipment / Tools	Quantity
1	LMV	02
2	Drivetrain system	01
3	Brake system (DISC, DRUM & ABS)	01
4	Steering system	01
5	Suspension system	01
6	CRDI Fuel system	01
7	MPFI Fuel system	01
8	Coolant system	01
9	Tyres	01
10	Wheel balancer	01
11	Vehicle lift	01
12	Hydraulic press	01
13	Transmission jack	01
14	Jack and Jack stand	01
15	Vehicle service manual	Sufficient quantity
16	Automobile Shop floor tools	Sufficient quantity
17	Tool box	Sufficient quantity
18	Compression tester	05
19	Vacuum gauge	05
20	Safety equipment (gloves, goggles) & First aid kits	Sufficient quantity



1021235440	<b>Automobile Servicing Practical</b>	L	T	P	C
PRACTICUM		1	0	4	3

### END SEMESTER EXAMINATIONS – PRACTICAL EXAM

**Note:**

All the exercises / experiments should be completed before the Board Practical Examinations. End Semester Practical examination should be conducted for all the exercises / experiments for 100 Marks. Students will be permitted to select any one exercise by lot or question paper supplied by the DOTE Exam section shall be used.

The Practical Documents by the student should be submitted with a Bonafide Certificate.

PART	DESCRIPTION	MARKS
A	Aim & Tools Required	10
B	Procedure / Observation / Dismantle / Assemble	20
C	Report / Troubleshooting	20
D	Output / Result	10
E	Written Test (Theory Portions only)	30
F	Viva Voce	10
TOTAL		100

**Note:** For the written test 30 MCQ shall be asked from the theory portions.



1020235541	<b>CNC Programming</b>	L	T	P	C
PRACTICUM		1	0	4	3

### Introduction

Computer Numerical Control (CNC) programming is a vital subject for diploma engineering students, focusing on the automation of machine tools through computer systems. CNC technology is foundational in modern manufacturing, allowing for precision, efficiency, and the ability to produce complex parts with minimal human intervention.

Proficiency in CNC programming opens up numerous career opportunities in various industries such as automotive, aerospace, manufacturing, and more. CNC programmers and operators are essential for creating high-quality, precision-engineered products.

This course equips students with the knowledge and skills necessary to excel in the dynamic and technologically advanced field of CNC machining, making them valuable assets in the engineering and manufacturing sectors.

### Course Objectives

The objective of this course is to prepare the student,

- To understand the fundamentals of CNC
- To explain the construction and tooling of the CNC machine
- To Programme Production Jobs for CNC Turning Centre for different operations
- To Programme production jobs for CNC Vertical Machining Centre for different operations
- To operate a CNC lathe
- To operate a CNC milling machine

### Course Outcomes

On successful completion of this course, the student will be able to,

- C01: Recall safety procedure to be followed while working in CNC Machines.
- C02: Create CNC part program for cylindrical components using CNC Turning Centre
- C03: Produce components using CNC Turning centre
- C04: Create CNC part program for rectangular components using CNC Machining Centre
- C05: Produce components using CNC Machining centre



1020235541	<b>CNC Programming</b>	L	T	P	C
PRACTICUM		1	0	4	3

**Pre-requisites**

Knowledge of CNC Machines, Tools and accessories.

**CO/PO Mapping**

CO / PO	PO1	PO2	PO3	PO4	PO5	PO6	PO7
<b>CO1</b>	3	2	2	3	1	3	3
<b>CO2</b>	3	2	3	3	2	3	3
<b>CO3</b>	3	3	2	3	1	3	3
<b>CO4</b>	3	2	3	3	1	3	3
<b>CO5</b>	3	2	3	3	2	3	3

Legend: 3-High Correlation, 2-Medium Correlation, 1-Low Correlation

**Instructional Strategy:**

- It is advised that teachers take steps to pique pupils' attention and boost their curiosity to learn.
- Implement task-based learning activities where students work on specific tasks or projects.
- Incorporate technology tools and resources, such as online platforms, interactive multimedia, and virtual communication tools, to enhance engagement and provide additional practice opportunities.
- Incorporate formative and summative assessments to gauge student progress and provide targeted feedback.
- Throughout the course, a theory-demonstrate-practice-activity strategy may be used to ensure that learning is outcome and employability based.
- All demonstrations/Hand-on practices may be followed in the real environment as far as possible.



1020235541	<b>CNC Programming</b>	L	T	P	C
PRACTICUM		1	0	4	3

**Assessment Methodology:**

	Continuous Assessment (40 marks)				End Semester Examination (60 marks)
	CA1	CA2	CA3	CA4	
<b>Mode</b>	Practical Test	Practical Test	Written Test Theory	Practical Test	Practical Examination
<b>Portion</b>	Cycle I Exercises	Cycle II Exercises	All Portions	All Exercises	All Exercises Experiments
<b>Duration</b>	2 Periods	2 Periods	3 Hours	3 Hours	3 hours
<b>Exam Marks</b>	60	60	100	100	100
<b>Converted to Marks</b>	10	10	15	15	60
<b>Marks</b>	10		15	15	60
<b>Tentative Schedule</b>	7th Week	14th Week	15th Week	16th Week	

Note:

- **CA1 and CA2:** All the exercises/experiments should be completed as per the portions above and kept for the practical test. The students shall be permitted to select any one by lot for the test. The practical test should be conducted as per the scheme of evaluation as below. The marks awarded shall be converted to 10 Marks for each assessment test. Best of one will be considered for the internal assessment of 10 Marks.

Practical documents should be maintained for every experiment immediately after completion of the practice. The practical document should be submitted for the practical test. The same should be evaluated for 10 Marks for each exercise/experiment. The total marks awarded should be converted to 10 Marks for the practical test as per the scheme of evaluation as below.



1020235541	<b>CNC Programming</b>	L	T	P	C
PRACTICUM		1	0	4	3

**The details of the documents to be prepared as per the instruction below.**

Each experiment should be completed on the day of practice. The same shall be evaluated for 10 marks on the day or next day of practice before commencement of the next experiment.

This documentation can be carried out in a separate notebook or a printed manual or a file with documents. The part program, procedure, sketch and output should be written by the student manually in the documents.

The detailed date of the practices and its evaluations should be maintained in the course logbook. The log book and the practical documents should be submitted for the verification by the Flying Squad and DOTE Official.

#### SCHEME OF EVALUATION

PART	DESCRIPTION	MARKS
<b>A</b>	Aim & Tools Required	10
<b>B</b>	Writing Part Program	20
<b>C</b>	Editing Program in machine and Component	20
TOTAL		50
<b>D</b>	Practical Documents (As per the portions)	10
		60

**Cycle I: 1, 2, 3 and 4.**

**Cycle II: 5, 6, 7, 8 and 9.**

- **CA 3:** Written Test for complete theory portions should be conducted for 100 Marks as per the question pattern below. The marks scored will be converted to 15 Marks for internal assessment.



1020235541	<b>CNC Programming</b>	L	T	P	C
PRACTICUM		1	0	4	3

**Question pattern – Written Test Theory**

Description		Marks	
Part – A	30 MCQ Questions.	30 X 1 Mark	30 Marks
Part – B	7 Questions to be answered out of 10 Questions.	7 X 10 Marks	70 Marks
TOTAL			100 Marks

- **CA 4:** All the exercises/experiments should be completed and kept for the practical test. The students shall be permitted to select any one by lot for the test. The practical test should be conducted as per the scheme of evaluation below. After completion of all the exercises the practical test should be conducted as per End Semester Examination question pattern scheme of evaluation. The marks awarded should be converted to 15 Marks for the internal assessment.

**SCHEME OF EVALUATION**

**Model Practical Examination and End Semester Examination - Practical Exam**

PART	DESCRIPTION	MARKS
<b>A</b>	Aim & Tools Required	10
<b>B</b>	Writing Part Program	20
<b>C</b>	Simulation	10
<b>D</b>	Editing Program in machine and Component	20
<b>E</b>	Written Test (Theory Portions)	30
<b>F</b>	Viva Voce	10
TOTAL		100

Note: For the written test 30 MCQ shall be asked from the theory portions.



1020235541	<b>CNC Programming</b>	L	T	P	C
PRACTICUM		1	0	4	3

### Syllabus contents

<b>THEORY</b>	
<p>Introduction to NC, CNC and DNC – Components of a CNC system: Program, Machine Control Unit, and Machine Tool – Toolings for CNC – ISO Designation for Tooling – Tool Material Selection – Tool Inserts.</p> <p>Steps involved in CNC Programming: Process Planning, Part Programming, Program Entry, Program Verification, and Production – Manual Part Programming, Data required for Manual Part Programming – Coordinate system – Designation of axes – Datum points and Reference Points – NC Dimensioning: Absolute, and Incremental - CNC Programming procedure – Format of a program.</p> <p>CNC Part Programming for Turning Centres – Axes system used for turning - Preparatory functions (G-Codes) for turning Centres – Auxiliary functions (M-Codes) for turning centres – Tool function codes – Speed function codes – Feed Specification codes - Rapid Positioning – Tool nose radius compensation - Linear Interpolation – Circular Interpolation/Filleting.</p> <p>Canned/Fixed Cycles: Box turning cycle (G90) - Taper turning (G90) – Facing/Taper facing cycle (G94) – Grooving/Parting cycle (G75) – Single threading cycle (G92) and Multiple threading cycle (G76) – Multiple turning cycle or Stock removal cycle (G70 &amp; G71) – Peck drilling cycle (G74) – Boring/Taper Boring cycle (G90)</p> <p>CNC Part Programming for Machining Centres – Axes system used for Machining centres - Preparatory functions (G-Codes) for Machining Centres – Auxiliary functions (M-Codes) for Machining centres – Preset – Cutter radius compensation – Tool length compensation - Linear Interpolation – Circular Interpolation.</p> <p>Canned Cycles: Drilling cycle (G81) – Counter sinking/Counter boring (G82) – Tapping cycle (G84) – Reaming Cycle (G85) – Boring Cycle (G86) – Peck</p>	15



1020235541	<b>CNC Programming</b>	L	T	P	C
PRACTICUM		1	0	4	3

drilling cycle (G83) – Sub Program – Mirroring – Circular Pocketing (G170 & G171) – Rectangular Pocketing (G172 & G173).		
Ex.No	Name of the Experiment	
1.	Write a Part Program for producing the component shown below in the turning center, simulate it and produce the component – Using Linear and Circular Interpolation. Raw Material Size: $\phi$ 30 mm dia x 41 mm length. Component Diagram:	5
2.	Write a Part Program for producing the component shown below in the turning center, simulate it and produce the component – Using Box turning cycle, Facing cycle, and Grooving cycle (G90, G94, and G75). Raw Material Size: $\phi$ 30 mm dia x 70 mm length Component Diagram: Note: Facing 0.5 mm (20 mm to 19.5 mm)	5
<p>1. Raw Material  2. Box turning Cycle (G90)  3. Taper Turning Cycle (G90)  4. Facing/Taper Facing Cycle (G94)  5. Grooving/Parting Cycle (G75)  6. Circular Interpolation</p>		

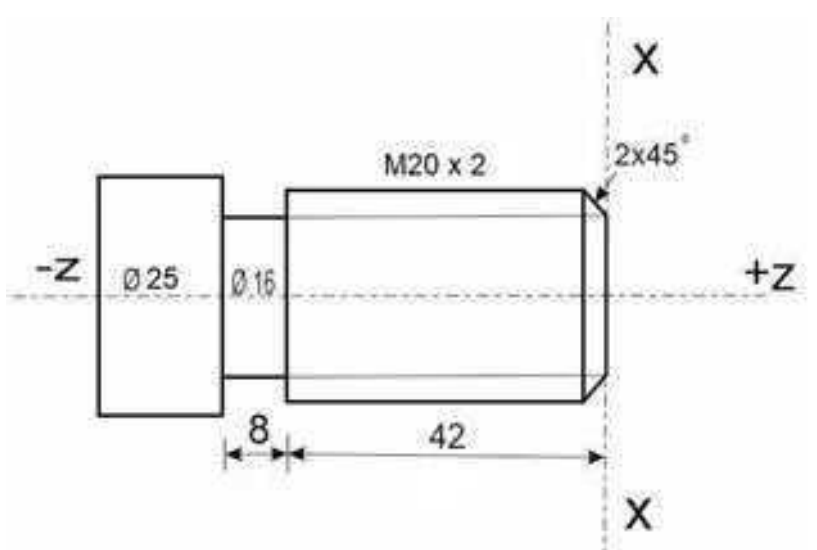
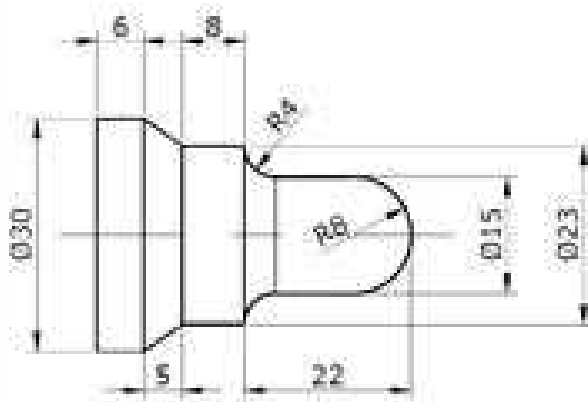

1020235541	<b>CNC Programming</b>	L	T	P	C
PRACTICUM		1	0	4	3

3.	<p>Write a Part Program for producing the component shown below in the turning center, simulate it and produce the component – Using the threading cycle (G92/G76).</p> <p>Raw Material Size: <math>\phi</math> 25 mm dia x 70 mm length</p> <p>Component Diagram:</p> 	5
4.	<p>Write a Part Program for producing the component shown below in the turning center, simulate it and produce the component – Using multiple turning cycle (G70 &amp; G71).</p> <p>Raw Material Size: <math>\phi</math> 30 mm dia x 41 mm length</p> <p>Component Diagram:</p> 	5

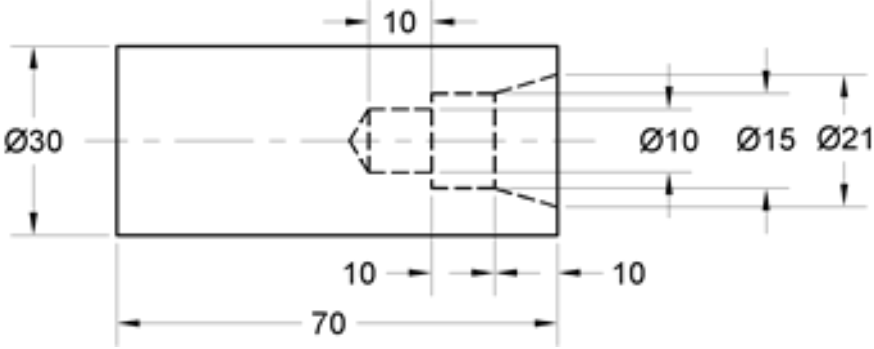
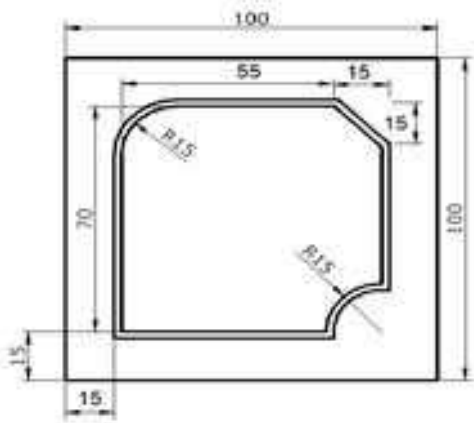

1020235541	<b>CNC Programming</b>	L	T	P	C
PRACTICUM		1	0	4	3

5.	<p>Write a Part Program for producing the component shown below in the turning center, simulate it and produce the component – Using Peck drilling and Boring cycles (G74 &amp; G90)</p> <p>Raw Material Size: <math>\phi</math> 30 mm dia x 70 mm length</p> <p>Component Diagram:</p> <p>Steps: (1). Pilot Drill – 3 mm dia, (2). Drill 10 mm dia, (3). Boring to 15 mm dia, (4). Taper Boring to 21 mm dia</p> 	5
6.	<p>Write a Part Program for producing the component shown below in the Machining center, simulate it and produce the component – Using Linear and Circular Interpolation</p> <p>Raw Material Size: 100 mm x 100 mm x 15 mm</p> <p>Component Diagram:</p> 	5

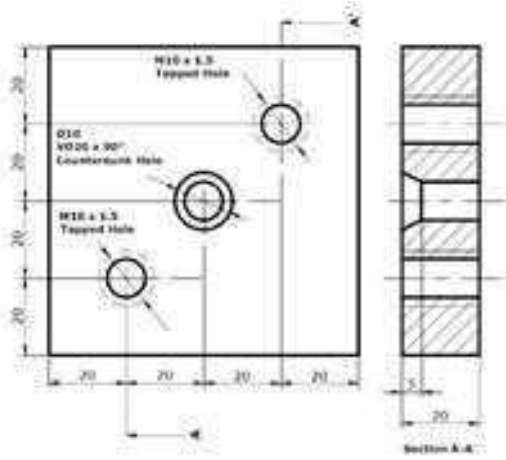
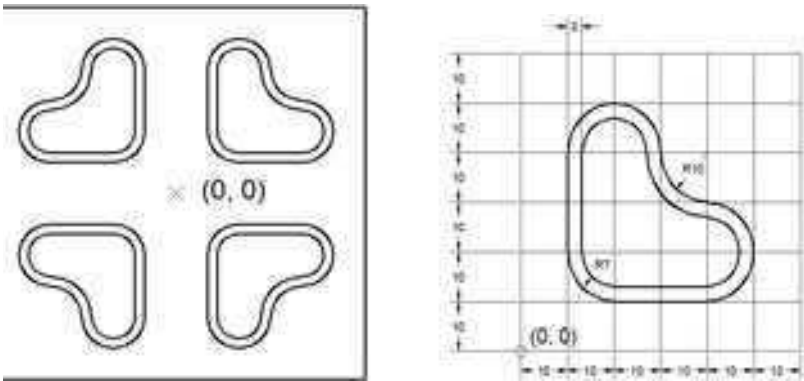

1020235541	<b>CNC Programming</b>	L	T	P	C
PRACTICUM		1	0	4	3

7.	<p>Write a Part Program for producing the component shown below in the Machining center, simulate it and produce the component – Using Peck drilling, Reaming, Tapping and counter-sinking cycles</p> <p>Raw Material Size: 80 mm x 80 mm x 20 mm</p> <p>Component Diagram:</p> 	5
8.	<p>Write a Part Program for producing the component shown below in the Machining center, simulate it and produce the component – Using Mirroring function</p> <p>Raw Material Size: 120 mm x 120 mm x 20 mm</p> <p>Component Diagram:</p> 	5



1020235541	<b>CNC Programming</b>	L	T	P	C
PRACTICUM		1	0	4	3

9.	<p>Write a Part Program for producing the component shown below in the Machining center, simulate it and produce the component – Using Circular and Rectangular Pocketing</p> <p>Raw Material Size: 100 mm x 100 mm x 20 mm</p> <p>Component Diagram:</p> <div style="text-align: center;"> </div>	5
Revision + Test		15
Total		75

**Textbook:**

1. S.K. Sinha, CNC Programming, Galgotia Publications Pvt Ltd., 2011
2. P. M. Agrawal, and V. J. Patel, CNC Fundamentals and Programming, First Edition, Charotar Publishing House Pvt. Limited, 2009.
3. Pawan Negi, Mangey Ram, and Om Prakash Yadav, Basics of CNC Programming, River Publishers, 2019
4. Peter Smid, CNC Control Setup for Milling and Turning Mastering CNC Control Systems, Industrial Press, 2010.

**Website links for reference:**

1. [https://www.youtube.com/watch?v=\\_5r2XR1h1aQ](https://www.youtube.com/watch?v=_5r2XR1h1aQ)
2. <https://www.youtube.com/watch?v=eJ432X2dR9A>



1020235541	<b>CNC Programming</b>	L	T	P	C
PRACTICUM		1	0	4	3

### END SEMESTER EXAMINATIONS – PRACTICAL EXAM

**Note:**

All the exercises/experiments should be completed before the Board Practical Examinations. End Semester Practical examination should be conducted for all the exercises / experiments for 100 Marks. Students will be permitted to select any one exercise by lot or question paper supplied by the DOTE Exam section shall be used. The practical document prepared by the student should be submitted with a Bonafide Certificate.

### SCHEME OF EVALUATION

PART	DESCRIPTION	MARKS
A	Aim & Tools Required	10
B	Writing Part Program	20
C	Simulation	10
D	Editing Program in machine and Component	20
E	Written Test	30
F	Viva Voce	10
TOTAL		100

Note: For the written test 30 MCQ shall be asked from the theory portions.

### LIST OF EQUIPMENT

1. CNC Turning centre - 2 No.
2. CNC Milling Centre - 2 No.
3. CNC Simulation Software
4. Computer - 30 Nos.



1021235542	<b>TWO-WHEELER AND THREE-WHEELER TECHNOLOGY</b>	L	T	P	C
PRACTICUM		1	0	4	3

**Introduction:**

There is an increase in need of public transport in cities and rural areas. This has led to huge demand for two and three wheelers. Presently Two and three wheelers play an important role in public transport all over the world. The practical subject is prerequisite for understanding concept of transmission unit, fuel system, electrical system Chassis, wheels, tires and maintenance and servicing of two and three wheelers

**Course Objectives:**

At the end of the course, the students will be able

- To demonstrate the various components of two and three wheelers by dismantling and reassemble the same
- To inspect the cooling system, lubrication system and fuel supply system after dismantling and assembling
- To dismantle, Inspect, overhaul and assemble the transmission system.
- To dismantle, Inspect, overhaul and assemble the final drive unit.
- To Inspect the front and rear suspension system after dismantling and assembling

**Course Outcomes:**

On successful completion of this course, the student will be able to

CO1: Understand the working of each component like engine, power unit and control systems in a two and three-wheelers and identify the components of the system

CO2: Evaluate the status of the lubricants and related systems namely engine, suspension, transmission in two and three wheelers and recommend the remedial solutions.

CO3: Analyse the cause of breakdown and prepare a list of troubleshooting method in a standardized prescribed format and identify the suitable rectification process.

CO4: Predict and recommend the maintenance practices in the service sector of two and three Wheelers and implement them practically.

CO5: Understand and restructure the emerging designs for new two and three wheelers and evaluate their merits and demerits.



1021235542	<b>TWO-WHEELER AND THREE-WHEELER TECHNOLOGY</b>	L	T	P	C
PRACTICUM		1	0	4	3

**Pre-requisites:**

NIL

**CO/PO Mapping**

CO / PO	PO1	PO2	PO3	PO4	PO5	PO6	PO7
<b>C01</b>	3	2	2	2	2	1	
<b>C02</b>	2	3	3	2	2	1	
<b>C03</b>	2	3	3	2	2	1	
<b>C04</b>	3	2	3	2	2	1	
<b>C05</b>	3	2	3	2	2	1	

Legend: 3-High Correlation, 2-Medium Correlation, 1-Low Correlation

**Instructional Strategy:**

- Direct instruction can also be called “teacher-led instruction. Teacher provides information, the students watch, listen and learn the practical skill under their supervision
- A teacher demonstrates a practical skill to the student using real time components or training kits.
- Each Practical learning had better be hands on training to develop employability skill to the students.



1021235542	<b>TWO-WHEELER AND THREE-WHEELER TECHNOLOGY</b>	L	T	P	C
PRACTICUM		1	0	4	3

**Assessment Methodology:**

	<b>Continuous Assessment (40 marks)</b>				<b>End Semester Examination (60 marks)</b>
	<b>CA1</b>	<b>CA2</b>	<b>CA3</b>	<b>CA4</b>	
<b>Mode</b>	Practical Test	Practical Test	Written Test Theory	Practical Test	Practical Examination
<b>Portion</b>	Cycle I Exercises	Cycle II Exercises	All Units	All Exercises	All Exercises
<b>Duration</b>	2 Periods	2 Periods	3 Hours	3 Hours	3 hours
<b>Exam Marks</b>	60	60	100	100	100
<b>Converted to Marks</b>	10	10	15	15	60
<b>Marks</b>	10		15	15	60
<b>Tentative Schedule</b>	7th Week	14th Week	15th Week	16th Week	

Note:

- **CA1 and CA2:** All the exercises/experiments should be completed as per the portions above and kept for the practical test. The students shall be permitted to select any one by lot for the test. The practical test should be conducted as per the scheme of evaluation as below. The marks awarded shall be converted to 10 Marks for each assessment test. Best of one will be considered for the internal assessment of 10 Marks.

Practical documents should be maintained for every exercise / experiment immediately after completion of the practice. The practical document should be submitted for the practical test. The same should be evaluated for 10 Marks for each exercise/experiment. The total marks awarded should be converted to 10 Marks for the practical test as per the scheme of evaluation as below.



1021235542	<b>TWO-WHEELER AND THREE-WHEELER TECHNOLOGY</b>	L	T	P	C
PRACTICUM		1	0	4	3

**The details of the practical documents are to be prepared as per the instructions below.**

Each exercise / experiment procedure, observation and calculations should be completed on the day of practice. The same shall be evaluated for 10 marks on the day or the next day of practice before the commencement of the next exercise.

This documentation can be carried out in a separate notebook or a printed manual or a file with documents. The observation, reading, calculations, report, graphs and results should be written by the student manually in the practical documents.

The evaluated practical document should be submitted for the Practical Test. The marks scored by the students should be converted to 10 marks. The same should be included as per the allocation in the practical test.

The detailed dates of the practices and its evaluations should be maintained in the course logbook. The log book and the practical documents should be submitted for the verification by the Flying Squad and DOTE Official.

#### SCHEME OF EVALUATION

PART	DESCRIPTION	MARKS
A	Aim & Tools Required	10
B	Procedure / Observation	20
C	Report / Troubleshooting	20
TOTAL		50
D	Practical Documents (As per the portions)	10
		60

**Cycle I:** 1, 2, 3, 4, 5 and 6.

**Cycle II:** 7, 8, 9, 10,11 and 12.



1021235542	<b>TWO-WHEELER AND THREE-WHEELER TECHNOLOGY</b>	L	T	P	C
PRACTICUM		1	0	4	3

- **CA 3:** Written Test for complete theory portions should be conducted for 100 Marks as per the question pattern below. The marks scored will be converted to 15 Marks for internal assessment.

#### Question pattern – Written Test Theory

Description		Marks	
Part – A	30 MCQ from the complete theory portions	30 X 1 Mark	30 Marks
Part – B	Seven Questions to be answered out of 10 Questions.	7 X 10 Marks	70 Marks
TOTAL			100 Marks

- **CA 4:** All the exercises/experiments should be completed and kept for the practical test. The students shall be permitted to select any one by lot for the test. The practical test should be conducted as per the scheme of evaluation below. After completion of all the exercises, the practical test should be conducted as per the End-Semester Examination question pattern scheme of evaluation. The marks awarded should be converted to 15 Marks for the internal assessment.

#### SCHEME OF EVALUATION

##### Model Practical Examination and End Semester Examination - Practical Exam

PART	DESCRIPTION	MARKS
A	Aim & Tools Required	10
B	Procedure / Observation	20
C	Report / Troubleshooting	20
D	Output / Result	10
E	Written Test (Theory Portions only)	30
F	Viva Voce	10
TOTAL		100

**Note:** For the written test 30 MCQ shall be asked from the theory portions.



1021235542	<b>TWO-WHEELER AND THREE-WHEELER TECHNOLOGY</b>	L	T	P	C
PRACTICUM		1	0	4	3

### Syllabus Contents

<b>Theory Portion - Unit I</b>	
<p>The power unit: Two stroke and four stroke - SI &amp; CI engine construction and working - Engine selection criteria for two-wheeler and three-wheeler. Valve operating mechanism. Symmetrical and unsymmetrical valve &amp; port timing diagrams.</p> <p>Fuel system: Carburettor – functions – working principle. Electronic petrol injection system. Lubrication system in four stroke engines Transmission system: Layout of transmission system – multi-disc clutch – chain drive – belt drive – gearbox: Constant mesh gear box working principle – gear shifting mechanism.</p>	7
<p><b>Practical Exercises</b></p> <p><b>Exercise 1:</b> Dismantle, check and assemble the engine cooling system of Three wheeler.</p> <p><b>Exercise 2:</b> Dismantle the valve seating arrangement and adjust the valve clearance.</p> <p><b>Exercise 3:</b> Check the engine oil level and replace the oil in Two wheeler.</p> <p><b>Exercise 4:</b> Dismantle and assemble the clutch used in a Three-wheeler.</p> <p><b>Exercise 5:</b> Adjust the clutch free play, throttle cable and inspect the common troubles and causes in Two wheeler.</p> <p><b>Exercise 6:</b> Overhaul and lubricate the gearbox of a Three-wheeler.</p>	25
<b>Theory Portion - Unit II</b>	
<p>Chassis: Layout of two-wheeler and three-wheeler vehicle. Different drive systems for two wheelers and three wheelers Main frame for two and three wheelers: Single cradle frame – double cradle frame - Tubular frame - twin-spar frame.</p> <p>Chassis: Conventional chassis –integral construction.</p> <p>Suspension systems: Front and rear suspension systems- Shock absorbers-leaf spring.</p> <p>Brakes and Wheels: Drum brakes &amp; Disc brakes for two and three wheelers - Construction and Working and its Types - Front and Rear brake link layouts. Brake actuation mechanism. Selection criteria of wheels and tires – Wheels: Spoked</p>	8



1021235542	<b>TWO-WHEELER AND THREE-WHEELER TECHNOLOGY</b>	L	T	P	C
PRACTICUM		1	0	4	3

wheel, cast wheel, Disc wheel & its merits and demerits. Tires and tubes Construction & its Types.	
<b>Practical Exercises</b> <b>Exercise 7:</b> Dismantle, lubricate and assemble the propeller shaft and differential. <b>Exercise 8:</b> Dismantle, lubricate and assemble the rear axle of the three-wheeler <b>Exercise 9:</b> Check frame alignment, dismantle and assemble the leaf spring assembly. <b>Exercise 10:</b> Dismantle and assemble the front suspension and rear suspension of a two-wheeler. <b>Exercise 11:</b> Remove the tire, lubricate bearings, refit and adjust the chain of the two-wheeler. <b>Exercise 12:</b> Dismantle, Service and assemble the disc brake system – Master cylinder, Wheel Cylinder, Caliper and brake pad of two-wheeler.	25
	Test + Revision 10
	Total 75

**Suggested List of Students Activity:**

- Have Motorcycle raiding activity with a proper trainer supervision.
- Visiting nearby two and three wheelers showrooms to know about different latest technology.
- Finding out the Morden working ethos of the servicing sector.

**Text book for Reference:**

1. Irving P.E Motorcycle Engineering. Temple Press Book London.
2. The Cycle Motor manual Temple Press Ltd London
3. Maintenance Manuals of Leading Two & Three Wheelers Manufacturers in India.
4. Dr.Kirpal Singh, Automobile Engineering Vol 1 & 2, Standard Publisher Distributors , Delhi
5. Dhruv U. Panchal, Two and Three-Wheeler Technology, PHI Learning Private Limited, Delhi



1021235542	<b>TWO-WHEELER AND THREE-WHEELER TECHNOLOGY</b>	L	T	P	C
PRACTICUM		1	0	4	3

**Equipment / Facilities required**

Sl. No.	Machinery's / Equipment / Tools	Quantity
1.	Two Wheeler	2
2.	Three Wheeler	1
3.	Special tools	5 sets
4.	Shop Floor Tools	3 sets
5.	Two Wheeler engine	1
6.	Three Wheeler Engine	1
7.	Spare components	Sufficient quantity.

**END SEMESTER EXAMINATIONS – PRACTICAL EXAM**

**Note:**

All the exercises / experiments should be completed before the Board Practical Examinations. End Semester Practical examination should be conducted for all the exercises / experiments for 100 Marks. Students will be permitted to select any one exercise by lot or question paper supplied by the DOTE Exam section shall be used.

The Practical Documents by the student should be submitted with a Bonafide Certificate.

PART	DESCRIPTION	MARKS
A	Aim & Tools Required	10
B	Procedure / Observation	20
C	Report / Troubleshooting	20
D	Output / Result	10
E	Written Test (Theory Portions only)	30
F	Viva Voce	10
TOTAL		100

**Note:** For the written test 30 MCQ shall be asked from the theory portions.



1020235543	<b>Industrial IoT</b>	L	T	P	C
PRACTICUM		1	0	4	3

**Introduction:**

Industrial Internet of Things or IIoT refers to interconnected instruments, sensors and other devices which can be networked together in an industrial setting. This connectivity enables remote access, efficient monitoring, data acquisition and collection, analysis and exchange of different data sources and a lot more. IIoT solutions have enormous potential for increasing productivity, and are also known for their low cost and quick implementation.

**Course Objectives:**

The objective of this course is to enable the student to

- Understand the application of IIoT in automation of commercial and real world applications.
- Summarize the functions of various types of sensors.
- Understand the Designing Industrial IOT Systems for various applications.
- Facilitate the students to design simple IIoT concepts.

**Course Outcomes:**

On successful completion of this course, the student will be able to

C01: Explain the basic computing features of the Arduino platform and programming.

C02: Adapt to the Arduino platform and display their name in the LCD display.

C03: Perform LED blinking and LED pattern creation with push button control with Arduino.

C04: Perform IR sensor interfacing, ultrasonic sensor interfacing and soil moisture interfacing with ESP32.

C05: Design a system that integrates ultrasonic sensors for accurate distance measurement.

**Pre-requisites:**

Applied Physics



1020235543	<b>Industrial IoT</b>	L	T	P	C
PRACTICUM		1	0	4	3

**CO/PO Mapping**

CO / PO	P01	P02	P03	P04	P05	P06	P07
<b>C01</b>	3	-	1	3	-	-	-
<b>C02</b>	3	-	1	3	-	-	-
<b>C03</b>	3	-	1	3	-	-	-
<b>C04</b>	3	-	1	3	-	-	-
<b>C05</b>	3	-	1	3	-	-	-

*Legend: 3-High Correlation, 2-Medium Correlation, 1-Low Correlation*

**Instructional Strategy:**

- It is advised that teachers take steps to increase the students' attention and boost their curiosity to learn.
- Implement task-based learning activities where students work on specific tasks or projects.
- Incorporate technology tools and resources, such as online platforms, interactive multimedia, and virtual communication tools, to enhance engagement and provide additional practice opportunities.
- Incorporate formative and summative assessments to measure student progress and provide targeted feedback.
- Throughout the course, a theory-demonstrate-practice-activity strategy may be used to ensure that learning is outcome and employability based.
- All demonstrations/Hand-on practices may be followed in the real environment as far as possible.



1020235543	<b>Industrial IoT</b>	L	T	P	C
PRACTICUM		1	0	4	3

**Assessment Methodology:**

	Continuous Assessment (40 marks)				End Semester Examination (60 marks)
	CA1	CA2	CA3	CA4	
<b>Mode</b>	Practical Test	Practical Test	Written Test Theory	Practical Test	Practical Examination
<b>Portion</b>	Cycle I Exercises	Cycle II Exercises	All Portions	All Exercises	All Exercises Experiments
<b>Duration</b>	2 Periods	2 Periods	3 Hours	3 Hours	3 hours
<b>Exam Marks</b>	60	60	100	100	100
<b>Converted to Marks</b>	10	10	15	15	60
<b>Marks</b>	10		15	15	60
<b>Tentative Schedule</b>	7th Week	14th Week	15th Week	16th Week	

Note:

- **CA1 and CA2:** All the exercises/experiments should be completed as per the portions above and kept for the practical test. The students shall be permitted to select any one by lot for the test. The practical test should be conducted as per the scheme of evaluation as below. The marks awarded shall be converted to 10 Marks for each assessment test. Best of one will be considered for the internal assessment of 10 Marks.

Practical documents should be maintained for every experiment immediately after completion of the practice. The practical document should be submitted for the practical test. The same should be evaluated for 10 Marks for each exercise/experiment. The total



1020235543	<b>Industrial IoT</b>	L	T	P	C
PRACTICUM		1	0	4	3

marks awarded should be converted to 10 Marks for the practical test as per the scheme of evaluation as below.

**The details of the documents to be prepared as per the instruction below.**

Each experiment should be completed on the day of practice. The same shall be evaluated for 10 marks on the day or next day of practice before commencement of the next experiment.

This documentation can be carried out in a separate notebook / printed manual / file. The Program, Procedure, Sketch and Output should be written by the student manually. The detailed date of the practices and its evaluations should be maintained in the course logbook. The log book and the practical documents should be submitted for the verification by the Flying Squad and DOTE Official.

#### SCHEME OF EVALUATION

PART	DESCRIPTION	MARKS
<b>A</b>	Aim & Tools Required	10
<b>B</b>	Procedure / Steps	20
<b>C</b>	Execution	20
TOTAL		50
<b>D</b>	Practical Documents (As per the portions)	10
		60

**Cycle I: 1, 2, 3 4, and 5.**

**Cycle II: 6, 7, 8, 9 and 10.**

- **CA 3:** Written Test for complete theory portions should be conducted for 100 Marks as per the question pattern below. The marks scored will be converted to 15 Marks for internal assessment.



1020235543	<b>Industrial IoT</b>	L	T	P	C
PRACTICUM		1	0	4	3

**Question pattern – Written Test Theory**

Description		Marks	
Part – A	30 MCQ Questions.	30 X 1 Mark	30 Marks
Part – B	7 Questions to be answered out of 10 Questions.	7 X 10 Marks	70 Marks
TOTAL			100 Marks

- **CA 4:** All the exercises/experiments should be completed and kept for the practical test. The students shall be permitted to select any one by lot for the test. The practical test should be conducted as per the scheme of evaluation below. After completion of all the exercises the practical test should be conducted as per End Semester Examination question pattern scheme of evaluation. The marks awarded should be converted to 15 Marks for the internal assessment.

**SCHEME OF EVALUATION**

**Model Practical Examination and End Semester Examination - Practical Exam**

PART	DESCRIPTION	MARKS
<b>A</b>	Aim & Tools Required	10
<b>B</b>	Procedure / Steps	20
<b>C</b>	Execution	20
<b>D</b>	Output / Result	10
<b>E</b>	Written Test	30
<b>F</b>	Viva Voce	10
TOTAL		100

Note: For the written test 30 MCQ shall be asked from the theory portions.



1020235543	<b>Industrial IoT</b>	L	T	P	C
PRACTICUM		1	0	4	3

### Syllabus Contents

Theory Portion		
UNIT I: INTRODUCTION TO INDUSTRIAL IOT (IIOT) SYSTEMS		Period
The Various Industrial Revolutions, Role of Internet of Things (IoT) & Industrial Internet of Things (IIoT) in Industry, Industry 4.0 revolutions, Support System for Industry 4.0, Smart Factories.		7
UNIT II: IMPLEMENTATION SYSTEMS FOR IIOT		
Sensors and Actuators for Industrial Processes, Sensor networks, Process automation and Data Acquisitions on IoT Platform, Microcontrollers and Embedded PC roles in IIoT, Wireless Sensor nodes with Bluetooth, WiFi, and LoRa Protocols and IoT Hub systems.		8
Practical Exercises:		
1	To implement LED Blink and LED pattern with Arduino	5
2	Creating different LED patterns and controlling with push button switches.	5
3	Automated LED light control based on input from IR sensor and LDR	5
4	To display your name in a LCD 16 x2 display with Arduino.	5
5	Controlling servo motors with the help of joystick	5
6	Measurement of temperature and Pressure using ESP32	5
7	Calculate the distance to an object with the help of an Ultrasonic sensor and display it on a LCD	5
8	Design a system that integrates ultrasonic sensors for accurate distance measurement in the identified areas.	5
9	integrate sensors such as GPS, accelerometers, and panic Basic Burglar alert security system with the help of PIR sensor and Buzzer	5
10	Modules and sensor interfacing - Interfacing IR sensor and LED with ESP32	5
Revision + Continuous Assessment		10
Total Period		75



1020235543	<b>Industrial IoT</b>	L	T	P	C
PRACTICUM		1	0	4	3

**Suggested List of Students Activity:**

1. Each students to write and submit the assignment on the topic 'Contrast IT and OT'
2. Four students can be grouped as a batch and practice an additional experiment to interface any one of the Arduino compatible sensors with Arduino and observe the behaviour of sensors.
3. Introduction to Arduino platform and programming
4. Study on various sensors and actuators.

**Text and Reference Books:**

1. Sudip Misra, Anandarup Mukherjee, Arijit Roy, Introduction to IoT, First Edition, Cambridge University Press, 2022.
2. Alasdair Gil Christ, Industry 4.0: The Industrial Internet of Things, Apress, Publications, 2016.
3. Sudan Jha, Usman Tariq, Gyanendra Prasad Joshi, Vijender Kumar Solanki, Industrial Internet of Things: Technologies, Design, and Applications, CRC Press, 2022.

**Web-based/Online Resources:**

[https://onlinecourses.nptel.ac.in/noc20\\_cs69/preview](https://onlinecourses.nptel.ac.in/noc20_cs69/preview)

**Equipment / Facilities required to conduct the Practical Course.**

S.No	Name of the Equipment's	Quantity Required
1.	Arduino UNO set	15
2.	ESP32 set -Type C	15
3.	LED Bulb	15
4.	Resistor	15
5.	Push button	15
6.	Servo motor 5V DC	15
7.	DC motor	15
8.	5V DC Relay	15



1020235543	<b>Industrial IoT</b>	L	T	P	C
PRACTICUM		1	0	4	3

9	Mini Breadboard	15
10	16 X 2 LCD Display with TTL	15
11	Gas sensor MQ2	15
12	IR Sensor	15
13	Temperature sensor DHT11 module	15
14	Ultrasonic sensor HC-SR04	15
15	Joystick module	15
16	Jumper wires - 3 nos.	As Required

### END SEMESTER EXAMINATIONS – PRACTICAL EXAM

**Note:**

All the exercises/experiments should be completed before the Board Practical Examinations. End Semester Practical examination should be conducted for all the exercises / experiments for 100 Marks. Students will be permitted to select any one exercise by lot or question paper supplied by the DOTE Exam section shall be used. The practical document prepared by the student should be submitted with a Bonafide Certificate.

### SCHEME OF EVALUATION

PART	DESCRIPTION	MARKS
A	Aim & Tools Required	10
B	Procedure / Steps	20
C	Execution	20
D	Output / Result	10
E	Written Test	30
F	Viva Voce	10
TOTAL		100

Note: For the written test 30 MCQ shall be asked from the theory portions.



1020235544	<b>Advanced Welding Technologies</b>	L	T	P	C
PRACTICUM		1	0	4	3

**Introduction:**

This syllabus outlines advanced welding technologies that covers various welding processes and techniques. The course is divided into 3 units that cover topics like introductory welding concepts, common arc and resistance welding processes, welding metallurgy, and weldment inspection and testing. The course aims to impart knowledge of advanced welding practices, welding process parameters, and the comparative merits of different welding methods. Students should learn to select the appropriate welding technique for various joint types and understand how to produce quality weldments.

**Course Objectives:**

1. To learn various concepts related to welding and its applications.
2. To have practical purview of various welding processes, welding standards, and advanced welding processes.
3. Familiarise with the working of the various welding processes.

**Course Outcomes:**

**On successful completion of this course, the student will be able to**

- C01: Explain the physics of Welding
- C02: Identify the appropriate Welding technique for the components
- C03: Select proper techniques to identify the welding defects
- C04: Acquire skills on advanced welding techniques
- C05: Demonstrate the necessary skills to identify the defects in welding.

**Pre-requisites:**

Knowledge of metal joining procedure



1020235544	<b>Advanced Welding Technologies</b>	L	T	P	C
PRACTICUM		1	0	4	3

**CO/PO Mapping**

CO / PO	P01	P02	P03	P04	P05	P06	P07
C01	3			3			
C02	3			3			
C03	3			3			
C04	3			3			
C05	3			3			

Legend: 3-High Correlation, 2-Medium Correlation, 1-Low Correlation

**Instructional Strategy:**

1. Engage and Motivate: Instructors should actively engage students to boost their learning confidence.
2. Real-World Relevance: Incorporate relatable, real-life examples and engineering applications to help students understand and appreciate course concepts.
3. Interactive Learning: Utilize demonstrations and plan interactive student activities for an engaging learning experience.
4. Application-Based Learning: Employ a theory-demonstrate-practice-activity strategy throughout the course to ensure outcome-driven learning and employability.
5. Simulation and Real-World Practice: Conduct demonstrations and hands-on activities in a simulated environment, transitioning to real-world scenarios when possible.
6. Encourage Critical Analysis: Foster an environment where students can honestly assess experiment outcomes and analyze potential sources of error in case of discrepancies



1020235544	<b>Advanced Welding Technologies</b>	L	T	P	C
PRACTICUM		1	0	4	3

**Assessment Methodology:**

	Continuous Assessment (40 marks)				End Semester Examination (60 marks)
	CA1	CA2	CA3	CA4	
<b>Mode</b>	Practical Test	Practical Test	Written Test Theory	Practical Test	Practical Examination
<b>Portion</b>	Cycle I Exercises	Cycle II Exercises	All Portions	All Exercises	All Exercises Experiments
<b>Duration</b>	2 Periods	2 Periods	3 Hours	3 Hours	3 hours
<b>Exam Marks</b>	60	60	100	100	100
<b>Converted to Marks</b>	10	10	15	15	60
<b>Marks</b>	10		15	15	60
<b>Internal Marks</b>	40				
<b>Tentative Schedule</b>	7th Week	14th Week	15th Week	16th Week	

Note:

- **CA1 and CA2:** All the exercises/experiments should be completed as per the portions above and kept for the practical test. The students shall be permitted to select any one by lot for the test. The practical test should be conducted as per the scheme of evaluation as below. The marks awarded shall be converted to 10 Marks for each assessment test. Best of one will be considered for the internal assessment of 10 Marks.

Practical documents should be maintained for every experiment immediately after completion of the practice. The practical document should be submitted for the practical test. The same should be evaluated for 10 Marks for each exercise/experiment. The total



1020235544	<b>Advanced Welding Technologies</b>	L	T	P	C
PRACTICUM		1	0	4	3

marks awarded should be converted to 10 Marks for the practical test as per the scheme of evaluation as below.

**The details of the documents to be prepared as per the instruction below.**

Each exercise should be completed on the day of practice.

The same shall be evaluated for 10 marks on the day or next day of practice before commencement of the next experiment.

This documentation can be carried out in a separate notebook / printed manual / file.

The Steps, Procedure, Sketch and Result should be written by the student manually.

The detailed date of the practices and its evaluations should be maintained in the course logbook. The log book and the practical documents should be submitted for the verification by the Flying Squad and DOTE Official.

#### SCHEME OF EVALUATION

PART	DESCRIPTION	MARKS
<b>A</b>	Joint Preparation	20
<b>B</b>	Procedure	20
<b>C</b>	Weld bead	10
TOTAL		50
<b>D</b>	Practical Documents (As per the portions)	10
		60

**Cycle - I      Exercise 1, 2, 3, 4, 5 and 6.**

**Cycle - II      Exercise 7, 8, 9, 10, 11 and 12.**

- **CA 3:** Written Test for complete theory portions should be conducted for 100 Marks as per the question pattern below. The marks scored will be converted to 15 Marks for internal assessment.



1020235544	<b>Advanced Welding Technologies</b>	L	T	P	C
PRACTICUM		1	0	4	3

**Question pattern – Written Test Theory**

Description		Marks	
Part – A	30 MCQ Questions.	30 X 1 Mark	30 Marks
Part – B	7 Questions to be answered out of 10 Questions.	7 X 10 Marks	70 Marks
TOTAL			100 Marks

- **CA 4:** All the exercises/experiments should be completed and kept for the practical test. The students shall be permitted to select any one by lot for the test. The practical test should be conducted as per the scheme of evaluation below. After completion of all the exercises the practical test should be conducted as per End Semester Examination question pattern scheme of evaluation. The marks awarded should be converted to 15 Marks for the internal assessment.

**SCHEME OF EVALUATION**

**Model Practical Examination and End Semester Examination - Practical Exam**

PART	DESCRIPTION	MARKS
<b>A</b>	Joint Preparation	20
<b>B</b>	Procedure	20
<b>C</b>	Weld bead	10
<b>D</b>	Finish	10
<b>E</b>	Written Test	30
<b>F</b>	Viva Voce	10
TOTAL		100

Note: For the written test 30 MCQ shall be asked from the theory portions.





1020235544	<b>Advanced Welding Technologies</b>	L	T	P	C
PRACTICUM		1	0	4	3

<b>Practical Exercises</b>		
<b>Exercises for Practical Exam.:</b>		40
<ol style="list-style-type: none"> <li>1. Make a butt and fillet joints by down hand welding (single V) using arc welding.</li> <li>2. Make a butt and fillet joints by vertical welding using arc welding.</li> <li>3. Welding of pipes using arc welding</li> <li>4. Butt welding of thin sheets leftward, rightward and downward using gas welding.</li> <li>5. Welding of tubes using gas welding.</li> <li>6. TIG welding practice – butt joint.</li> <li>7. MIG welding practice – butt joint.</li> <li>8. Spot welding practice in thin sheets.</li> <li>9. Inspection of welding – visual and magnetic particle test.</li> <li>10. Inspection of welding – die penetrant test and ultrasonic test.</li> </ol>		
Revision + Test		10
Total		75

**Cycle - I      Exercise 1, 2, 3, 4, 5 and 6.**

**Cycle - II      Exercise 7, 8, 9, 10, 11 and 12.**

**Suggested List of Students Activity:**

- Observe the welding machine in the institute and study its specifications. List the possibility of different method of weld joints that can be used.
- Study the type of current used in the welding machine and draw the circuit diagram.
- Study the types of electrode used and its industrial applications.



1020235544	<b>Advanced Welding Technologies</b>	L	T	P	C
PRACTICUM		1	0	4	3

**Text and Reference Books:**

1. Advance Welding Technology by S.A. Rizvi , S.K. Kataria & Sons. 4th, reprint 2019.
2. Welding Engineering and Technology by R.S. PARMAR, IIT, Delhi, Kanna Publishers, 1999.
3. Welding principles and practices by Edward R. Bohnart, Mc. Graw Hill Education, 2014.

**WEB REFERENCE**

- <https://archive.nptel.ac.in/courses/112/103/112103263/#>
- <https://archive.nptel.ac.in/courses/112/103/112103244/>
- <https://archive.nptel.ac.in/courses/112/107/112107089/>
- <https://youtube.com/playlist?list=PLwdnzlV3ogoW9g44SFbiiCjyMOMPnNBL8&feature=shared>

**END SEMESTER EXAMINATIONS – PRACTICAL EXAM**

**Note:**

All the exercises/experiments should be completed before the Board Practical Examinations. End Semester Practical examination should be conducted for all the exercises / experiments for 100 Marks. Students will be permitted to select any one exercise by lot or question paper supplied by the DOTE Exam section shall be used. The practical document prepared by the student should be submitted with a Bonafide Certificate.

**SCHEME OF EVALUATION**

PART	DESCRIPTION	MARKS
A	Joint Preparation	20
B	Procedure	20
C	Weld bead	10
D	Finish	10
E	Written Test (Theory Portions)	30
F	Viva Voce	10
TOTAL		100

Note: For the written test 30 MCQ shall be asked from the theory portions.



1020235545	<b>Industrial Robotics</b>	L	T	P	C
PRACTICUM		1	0	4	3

### Introduction

It has been realized that rapid industrialization and globalization needs industries to be more competitive and deliver cost effective quality products. This needs industries to implement flexible manufacturing systems where Robotic technology plays a major role. Hence study of robotic technology is very essential, To acquire knowledge about the hydraulic and pneumatic systems and its functions of the components. Understand the control methods of automation.

### Course Objectives

The objective of this course is to prepare the student,

- To understand the basics of robot components and process automation.
- To execute the Robot programming using simulation software.
- To execute the Robot programming and Execute.
- To perform the basics of robotics and simulation of software fixtures for material handling and industrial applications.
- To execute program for various applications in manufacturing by using robot programming and industrial safety systems.
- To learn about the software and hardware systems for industrial Robotics

### Course Outcomes

On successful completion of this course, the student will be able to,

CO1: Describe the components of Robot and its joints & links in Robot configuration,

CO2: Classify the robot controller Drives and grippers,

CO3: Explain industrial applications of robot in Manufacturing environment

CO4: Generate robot program for material handling applications

CO5: Execute / Simulate programs for various applications in manufacturing by using robot programming.



1020235545	<b>Industrial Robotics</b>	L	T	P	C
PRACTICUM		1	0	4	3

**Pre-requisites**

Knowledge of Basic Robot Engineering, Robot software, Robot programming .

**CO/PO Mapping**

CO / PO	P01	P02	P03	P04	P05	P06	P07
<b>C01</b>	3			2			1
<b>C02</b>	3			2			1
<b>C03</b>	3			2			1
<b>C04</b>	3			2			1
<b>C05</b>	3			2			1

Legend: 3-High Correlation, 2-Medium Correlation, 1-Low Correlation

**Instructional Strategy**

Active Learning: Activities for active learning can include think-pair-share strategies as well as kin-esthetic learning environment. Teachers can start a discussion to make sure students take ownership over their own participation and talk through new ideas and skills with peers. Teachers guide students as they construct their own knowledge and understanding.

Hands-on-Training: Conduct demonstrations and hands on training is all about applying the knowledge you have learned in training into practice.

Real time Learning: Instructors encourage the students to implement the techniques in their own place / Lab through the Industry-Institute interactions.



1020235545	<b>Industrial Robotics</b>	L	T	P	C
PRACTICUM		1	0	4	3

**Assessment Methodology:**

	Continuous Assessment (40 marks)				End Semester Examination (60 marks)
	CA1	CA2	CA3	CA4	
<b>Mode</b>	Practical Test	Practical Test	Written Test Theory	Practical Test	Practical Examination
<b>Portion</b>	Cycle I Exercises	Cycle II Exercises	All Portions	All Exercises	All Exercises Experiments
<b>Duration</b>	2 Periods	2 Periods	3 Hours	3 Hours	3 hours
<b>Exam Marks</b>	60	60	100	100	100
<b>Converted to Marks</b>	10	10	15	15	60
<b>Marks</b>	10		15	15	60
<b>Internal Marks</b>	40				
<b>Tentative Schedule</b>	7th Week	14th Week	15th Week	16th Week	

Note:

- **CA1 and CA2:** All the exercises/experiments should be completed as per the portions above and kept for the practical test. The students shall be permitted to select any one by lot for the test. The practical test should be conducted as per the scheme of evaluation as below. The marks awarded shall be converted to 10 Marks for each assessment test. Best of one will be considered for the internal assessment of 10 Marks.

Practical documents should be maintained for every experiment immediately after completion of the practice. The practical document should be submitted for the practical test. The same should be evaluated for 10 Marks for each exercise/experiment. The total



1020235545	<b>Industrial Robotics</b>	L	T	P	C
PRACTICUM		1	0	4	3

marks awarded should be converted to 10 Marks for the practical test as per the scheme of evaluation as below.

**The details of the documents to be prepared as per the instruction below.**

Each exercise should be completed on the day of practice. The same shall be evaluated for 10 marks on the day or next day of practice before commencement of the next experiment.

This documentation can be carried out in a separate notebook / printed manual / file. The Steps, Procedure, Sketch and Result should be written by the student manually. The detailed date of the practices and its evaluations should be maintained in the course logbook. The log book and the practical documents should be submitted for the verification by the Flying Squad and DOTE Official.

#### SCHEME OF EVALUATION

PART	DESCRIPTION	MARKS
<b>A</b>	Step / Procedure	10
<b>B</b>	Write Program	20
<b>C</b>	Edit Program / Simulate / Execution	20
TOTAL		50
<b>D</b>	Practical Documents (As per the portions)	10
		60

**Cycle - I      Exercise 1, 2, 3, 4 and 5.**

**Cycle - II      Exercise 6, 7, 8, 9, 10 and 11.**

- **CA 3:** Written Test for complete theory portions should be conducted for 100 Marks as per the question pattern below. The marks scored will be converted to 15 Marks for internal assessment.

#### Question pattern – Written Test Theory

**DIRECTORATE OF TECHNICAL EDUCATION, CHENNAI – 600 025  
REGULATION 2023**



1020235545	<b>Industrial Robotics</b>	L	T	P	C
PRACTICUM		1	0	4	3

Description		Marks	
Part – A	30 MCQ Questions.	30 X 1 Mark	30 Marks
Part – B	7 Questions to be answered out of 10 Questions.	7 X 10 Marks	70 Marks
TOTAL			100 Marks

- **CA 4:** All the exercises/experiments should be completed and kept for the practical test. The students shall be permitted to select any one by lot for the test. The practical test should be conducted as per the scheme of evaluation below. After completion of all the exercises the practical test should be conducted as per End Semester Examination question pattern scheme of evaluation. The marks awarded should be converted to 15 Marks for the internal assessment.

#### SCHEME OF EVALUATION

##### Model Practical Examination - Practical Exam

PART	DESCRIPTION	MARKS
<b>A</b>	Step / Procedure	10
<b>B</b>	Write Program	20
<b>C</b>	Edit Program / Simulate / Execution	20
<b>D</b>	Result / Finish / Accuracy	10
<b>E</b>	Written Test	30
<b>F</b>	Viva Voce	10
TOTAL		100

Note: For the written test 30 MCQ shall be asked from the theory portions.



1020235545	<b>Industrial Robotics</b>	L	T	P	C
PRACTICUM		1	0	4	3

### Syllabus contents

THEORY	
<p>Introduction – Definitions of Robot -Robot Anatomy – Basic configuration of Robotics – Robot Components – Manipulator, End effector, Driving system, Controller and Sensors. Mechanical arm –</p> <p>Degrees of freedom – Links and joints – Types of joints – Joint notation scheme – Pitch, Yaw, Roll – Classification of robots – Work envelope, Work Volume.</p> <p>Robot controller – Configuration - Four types of controls – Open loop and closed loop controls – Speed of response and stability – Precision of movements: Spatial resolutions, accuracy and repeatability. Pneumatic drives – Hydraulic drives – Mechanical drives – Electrical drives –Stepper motors, DC Servo motors and AC Servo motors – Salient features – Applications and Comparisons of Drives. End effecters –Grippers – Mechanical Grippers, Magnetic Grippers, Vacuum Grippers, Two fingered and Three fingered Grippers, Internal and External Grippers,</p> <p>– End Of Arm Tooling (EOAT)- Selection and Design considerations</p> <p>Robot applications – Material handling – Press loading and unloading –Die casting – Machine tool loading and unloading – Spot welding – Arc welding – Spray painting – Assembling – Finishing – Automatic Guided Vehicle – Adopting robots to workstations – Requisite robot characteristics and Non requisite robot characteristics – Stages in selecting robots for industrial applications – Safety considerations for robot operations – Robotics in the future and characteristics task–Economical analysis of robots – Social implications.</p>	15
<p><b>Practice</b></p> <p>Study of Robot system, Study and practice in the robot simulation software .</p>	6



1020235545	<b>Industrial Robotics</b>	L	T	P	C
PRACTICUM		1	0	4	3

### Practical Exercise

Ex.No	Name of the Experiment	
1.	Programming using Position recording using Cartesian co-ordinate system - (No. of positions – 9).	4
2.	Programming using Position recording using Polar co-ordinate system - (No. of positions - 9).	4
3.	Programming using Loops and sub – routine.	4
4.	Pick and place of objects (No. of objects to be specified- 6).	4
5.	Pick and stack of objects (No. of objects to be specified- 6).	4
6.	Arc welding practice(Length. of weld to be specified).	4
7.	Programming using Spot welding practice - (No. of spots Minimum 3).	4
8.	Assembling practice (Simple assembling).	4
9.	Profile cutting practice (combination of lines and arcs).	4
10.	Programming for Spray painting practice - (Area - 300mm x 300mm).	4
11.	Programming using Machine loading and unloading practice with time delay.	4
Revision + Assessment		10
Total		75

### Textbook:

1. Mikell P Groover, Mitchell Weiss, Roger N Nagel, Nicholas Odrey, and Ashish Dutta, Industrial Robotics – Technology, Programming and Applications, 2nd Edition, McGraw Hill, 2013.
2. Appuu Kuttan, Robotics, I.K. International Publishing House Pvt. Limited, 2013
3. Ganesh S. Hegde, A Textbook of Industrial Robotics, Second Edition, Laxmi Publications (P) Ltd., 2015
4. Nagarajan Ramachandran, Introduction to Industrial Robotics, Pearson India Education Services Pvt. Ltd., 2016



1020235545	<b>Industrial Robotics</b>	L	T	P	C
PRACTICUM		1	0	4	3

**Website links for reference:**

- [https://www.youtube.com/playlist?list=PLyqSpQzTE6M\\_XM9cvjLLO\\_Azt1FkgPhpH](https://www.youtube.com/playlist?list=PLyqSpQzTE6M_XM9cvjLLO_Azt1FkgPhpH)
- [https://www.youtube.com/playlist?list=PLFW6IRTa1g81AGUOky\\_xVhNVsudGwZxsY](https://www.youtube.com/playlist?list=PLFW6IRTa1g81AGUOky_xVhNVsudGwZxsY)

**LIST OF EQUIPMENTS**

1. Robot simulation software or Robotic arm
2. Computer - 30 Nos.

**END SEMESTER EXAMINATIONS – PRACTICAL EXAM**

**Note:**

All the exercises/experiments should be completed before the Board Practical Examinations. End Semester Practical examination should be conducted for all the exercises / experiments for 100 Marks. Students will be permitted to select any one exercise by lot or question paper supplied by the DOTE Exam section shall be used. The practical document prepared by the student should be submitted with a Bonafide Certificate.

**SCHEME OF EVALUATION**

PART	DESCRIPTION	MARKS
<b>A</b>	Step / Procedure	10
<b>B</b>	Write Program	20
<b>C</b>	Edit Program / Simulate / Execution	20
<b>D</b>	Result / Finish / Accuracy	10
<b>E</b>	Written Test (Theory Portions)	30
<b>F</b>	Viva Voce	10
TOTAL		100

Note: For the written test 30 MCQ shall be asked from the theory portions.



1020235546	<b>HVAC Systems and Components</b>	L	T	P	C
PRACTICUM		1	0	4	3

**Introduction:**

To impart knowledge about HVAC system components, handling the components and testing the performance is very much needed. This content would be useful to select the various types of components to be used in HVAC systems with different capacities. The knowledge about VFD compressors and capacity calculation of cooling coils is very essential in the present scenario.

**Course Objectives:**

The objective of this course is to enable the student to

- Practice, set and adjust the LP and HP cut-out, TEV and thermostat in refrigeration systems.
- Test the capacitor and selector switch for its working.
- Test the pumping capacity of sealed compressor.
- Determine the capacity of fan and evaporator coil of window air conditioner.
- Determine the capacity of air cooled condenser of split air conditioner.
- Determine the range, approach and efficiency of cooling tower.

**Course Outcomes**

After successful completion of this course, the students should be able to,

C01: Explain the construction and working of compressor and condenser.

C02: Explain the functions of expansion valve and evaporator.

C03: Describe the different components in the HVAC system.

C04: Demonstrate the various processes of HVAC system.

C05: Demonstrate the electrical components used in HVAC system.

**Pre-requisites:**

Basic knowledge of HVAC Components.



1020235546	<b>HVAC Systems and Components</b>	L	T	P	C
PRACTICUM		1	0	4	3

**CO/PO Mapping**

CO / PO	P01	P02	P03	P04	P05	P06	P07
<b>C01</b>	3			3			
<b>C02</b>	3			3			
<b>C03</b>	3			3			
<b>C04</b>	3			3			
<b>C05</b>	3			3			

Legend: 3-High Correlation, 2-Medium Correlation, 1-Low Correlation

**Instructional Strategy:**

- It is advised that teachers take steps to pique pupils' attention and boost their learning confidence.
- To help students learn and appreciate numerous concepts and principles in each area, teachers should provide examples from daily life, realistic situations, and real-world engineering and technological applications.
- The demonstration can make the subject exciting and foster in the students a scientific mindset. Student activities should be planned on all the topics.
- Throughout the course, a theory-demonstrate-practice-activity strategy may be used to ensure that learning is outcome and employability based.
- All demonstrations/Hand-on practices are under a simulated environment (may be followed by a real environment as far as possible).



1020235546	<b>HVAC Systems and Components</b>	L	T	P	C
PRACTICUM		1	0	4	3

**Assessment Methodology:**

	<b>Continuous Assessment (40 marks)</b>				<b>End Semester Examination (60 marks)</b>
	<b>CA1</b>	<b>CA2</b>	<b>CA3</b>	<b>CA4</b>	
<b>Mode</b>	Practical Test	Practical Test	Written Test Theory	Practical Test	Practical Examination
<b>Portion</b>	Cycle I Exercises	Cycle II Exercises	All Portions	All Exercises	All Exercises Experiments
<b>Duration</b>	2 Periods	2 Periods	3 Hours	3 Hours	3 hours
<b>Exam Marks</b>	60	60	100	100	100
<b>Converted to Marks</b>	10	10	15	15	60
<b>Marks</b>	10		15	15	60
<b>Tentative Schedule</b>	7th Week	14th Week	15th Week	16th Week	

Note:

**CA1 and CA2:** All the exercises/experiments should be completed as per the portions above and kept for the practical test. The students shall be permitted to select any one by lot for the test. The practical test should be conducted as per the scheme of evaluation as below. The marks awarded shall be converted to 10 Marks for each assessment test. Best of one will be considered for the internal assessment of 10 Marks.

Practical documents should be maintained for every experiment immediately after completion of the practice. The practical document should be submitted for the practical test. The same should be evaluated for 10 Marks for each exercise/experiment. The total marks awarded should be converted to 10 Marks for the practical test as per the scheme of evaluation as below.



1020235546	<b>HVAC Systems and Components</b>	L	T	P	C
PRACTICUM		1	0	4	3

**The details of the documents to be prepared as per the instruction below.**

Each exercise should be completed on the day of practice.

The same shall be evaluated for 10 marks on the day or next day of practice before commencement of the next experiment.

This documentation can be carried out in a separate notebook / printed manual / file.

The Steps, Procedure, Sketch and Result should be written by the student manually.

The detailed date of the practices and its evaluations should be maintained in the course logbook. The log book and the practical documents should be submitted for the verification by the Flying Squad and DOTE Official.

#### SCHEME OF EVALUATION

PART	DESCRIPTION	MARKS
<b>A</b>	Aim / Procedure	10
<b>B</b>	Tools required / Observation	20
<b>C</b>	Diagrams / Tabulation and calculation / Setting / Adjusting	20
TOTAL		50
<b>D</b>	Practical Documents (As per the portions)	10
		60

**Cycle - I      Exercise 1, 2, 3, 4, 5 and 6.**

**Cycle - II      Exercise 7, 8, 9, 10, 11 and 12.**

**CA 3:** Written Test for complete theory portions should be conducted for 100 Marks as per the question pattern below. The marks scored will be converted to 15 Marks for internal assessment.



1020235546	<b>HVAC Systems and Components</b>	L	T	P	C
PRACTICUM		1	0	4	3

**Question pattern – Written Test Theory**

Description		Marks	
Part – A	30 MCQ Questions.	30 X 1 Mark	30 Marks
Part – B	7 Questions to be answered out of 10 Questions.	7 X 10 Marks	70 Marks
TOTAL			100 Marks

**CA 4:** All the exercises/experiments should be completed and kept for the practical test. The students shall be permitted to select any one by lot for the test. The practical test should be conducted as per the scheme of evaluation below. After completion of all the exercises the practical test should be conducted as per End Semester Examination question pattern scheme of evaluation. The marks awarded should be converted to 15 Marks for the internal assessment.

**SCHEME OF EVALUATION**

**Model Practical Examination - Practical Exam**

PART	DESCRIPTION	MARKS
A	Aim / Procedure	10
B	Tools required / Observation	20
C	Diagrams / Tabulation and calculation / Setting / Adjusting	20
D	Result / Report	10
E	Written Test	30
F	Viva Voce	10
TOTAL		100

Note: For the written test 30 MCQ shall be asked from the theory portions.

**Syllabus Contents**

<b>Unit 1</b>	<b>Compressor</b>	
Compressor – Introduction - functions of a compressor – Classification - open type reciprocating compressor – Hermetically sealed compressors – construction and working		3



1020235546	<b>HVAC Systems and Components</b>	L	T	P	C
PRACTICUM		1	0	4	3

<b>Unit II</b>	<b>Condenser</b>			
Condenser - Introduction – Functions --Classification of condensers – Air cooled condenser, Water cooled condenser - Construction and Working				3
<b>Unit III</b>	<b>Expansion device</b>			
3.1 Expansion devices- Introduction – Functions – Types of expansion devices –Capillary tube, Automatic expansion valve, Thermostatic expansion valve – Construction and working only.				3
<b>Unit IV</b>	<b>Evaporator</b>			
Evaporator - Introduction – Functions - Types of evaporators – Bare tube coil evaporators- Finned evaporators – Construction and working only.				3
<b>Unit V</b>	<b>HVAC System Controls and Fans</b>			
5.1 Motor Operating Components: Selector switch – OLP – Relay – Capacitor – Starting, Running. System Controls: LP, HP cutout -- Humidity control – Thermostat switch – Solenoid valve.				3
5.2 Fans – Introduction - function of fans - Types of fans - centrifugal fans - Axial flow fan – Propeller fan, Tube axial fan and vane axial fan – Construction and working only.				

<b>Practical Exercise</b>		
<b>Ex. No</b>	<b>Name of the Exercise</b>	<b>Periods</b>
1	Charging of Refrigerant in a refrigeration System	4
2	Pump down of refrigerant from the refrigeration System	4
3	Find out the leak in the refrigeration System and rectify the defect	4
4	Charging of oil in the refrigeration System	4
5	Setting and Adjusting the thermostat.	4
6	Setting and Adjusting of low pressure and High pressure cut out in VCR system.	4



1020235546	<b>HVAC Systems and Components</b>	L	T	P	C
PRACTICUM		1	0	4	3

7	Setting and Adjusting of thermostatic expansion valve.	4
8	Testing the pumping capacity of a sealed compressor.	4
9	Testing and Replacement of faulty capacitor and selector switch.	4
10	Determination of capacity of fan.	4
11	Determination of capacity of evaporator coil of window / Split Air conditioner	4
12	Determination of capacity of air cooled condenser of a Window / Split Air conditioner	4
Revision + Test		12
Total		75

**Suggested List of Students Activity:**

1. Prepare/Download a specification of the following:
2. Various tools, Equipments and controls used in HVAC systems
3. Presentation / seminar by students on HVAC systems

**TEXT BOOKS and REFERENCES**

1. ASHRAE Hand Book Heating, ventilating and Air-conditioning systems and equipment.
2. The Institute of Plumbing - Plumbing Engineering Services Design Guide.
3. Principles of Electrical and Engineering and Electronics by V.K.Mehta and Rohit Mehta.

**Web-based/Online Resources:**

- <https://youtu.be/IKn3c7Sup9k?si=eWDXDgmNGB-RnGs7>
- <https://youtu.be/PjcdqAkP0UA?si=lk-us0HFvDgver4M>
- [https://youtu.be/QgVnRsdoxwQ?si=uf3JHI\\_hqwK2nkRR](https://youtu.be/QgVnRsdoxwQ?si=uf3JHI_hqwK2nkRR)
- <https://youtu.be/6YiCjnjLKH8?si=SSc125M7ZIDARi9t>



1020235546	<b>HVAC Systems and Components</b>	L	T	P	C
PRACTICUM		1	0	4	3

### END SEMESTER EXAMINATIONS – PRACTICAL EXAM

**Note:**

All the exercises/experiments should be completed before the Board Practical Examinations. End Semester Practical examination should be conducted for all the exercises / experiments for 100 Marks. Students will be permitted to select any one exercise by lot or question paper supplied by the DOTE Exam section shall be used. The practical document prepared by the student should be submitted with a Bonafide Certificate.

### SCHEME OF EVALUATION

PART	DESCRIPTION	MARKS
<b>A</b>	Aim / Procedure	10
<b>B</b>	Tools required / Observation	20
<b>C</b>	Diagrams / Tabulation and calculation / Setting / Adjusting	20
<b>D</b>	Result / Report	10
<b>E</b>	Written Test	30
<b>F</b>	Viva Voce	10
TOTAL		100

Note: For the written test 30 MCQ shall be asked from the theory portions.

### Equipment / Facilities required to conduct the Practical Course.

Sl.No	Equipments	Nos
01	VCR experimental setup with thermostat, LP HP cutouts and TEV	1
02	Sealed compressor and gauge manifold set	1
03	Experimental setup for testing capacitor and selector switch	1
04	Experimental setup for determining capacity of fan and anemometer	1
05	Window air conditioner experimental setup for finding the capacity of evaporator	1
06	Split air conditioner experimental setup for finding the capacity of air cooled condenser	1
07	Cooling tower experimental setup	1



1021235547	<b>ENGINE TESTING</b>	L	T	P	C
PRACTICUM		1	0	4	3

**Introduction:**

Engine testing is a fundamental aspect of automobile engineering that involves the evaluation and analysis of internal combustion engines. As a cornerstone of automotive technology, engine testing ensures that engines meet performance, efficiency, and emissions standards. In this subject, students will delve into the various methods and tools used to test engine components and systems.

Understanding engine testing is crucial for diagnosing issues, enhancing performance, and ensuring the reliability and longevity of automotive engines. This subject will cover a range of topics, including dynamometer testing, fuel consumption measurement, emission analysis, and the latest advancements in engine testing technology.

Through a combination of theoretical knowledge and practical application, students will gain insights into the intricate workings of engines and the critical role testing plays in the automotive industry. By the end of this course, students will be equipped with the skills and knowledge to conduct comprehensive engine tests, analyze data, and contribute to the development of more efficient and environmentally friendly engines.

**Course Objectives:**

- Gain comprehensive knowledge of the components of the engine block.
- Develop the ability to perform various testing and adjustment of valves.
- Acquire hands-on experience by dismantling and assembling with proper equipment and tools.
- Understand and implement safety protocols and environmental regulations related to engine testing, ensuring safe working practices and compliance with emission standards.



1021235547	<b>ENGINE TESTING</b>	L	T	P	C
PRACTICUM		1	0	4	3

**Course Outcomes:**

On successful completion of this course, the student will be able to

CO 1: Identify the components of the Engine Block.

CO 2: Demonstrate the ability to calibrate the fuel pump.

CO 3: Apply their understanding of internal combustion engine injection principles.

CO 4: Acquire knowledge on engine parts by dismantling and assembly.

CO 5: Acquire hands-on experience by dismantling and assembly of radiator and cooling pump.

**Pre-requisites:**

NIL

**CO/PO Mapping**

CO / PO	P01	P02	P03	P04	P05	P06	P07
<b>C01</b>	2	2	1	2			
<b>C02</b>	2	2	1	2			
<b>C03</b>	2	2	1	2			
<b>C04</b>	2	2	1	2			
<b>C05</b>	2	2	1	2			

Legend: 3-High Correlation, 2-Medium Correlation, 1-Low Correlation

**Instructional Strategy:**

- Direct instruction can also be called “teacher-led instruction. Teacher provides information, the students watch, listen and learn the practical skill under their supervision



1021235547	<b>ENGINE TESTING</b>	L	T	P	C
PRACTICUM		1	0	4	3

- A teacher demonstrates a practical skill to the student using real time components or training kits.
- Each Practical learning had better be hands on training to develop employability skills to the students.

**Assessment Methodology:**

	Continuous Assessment (40 marks)				End Semester Examination (60 marks)
	CA1	CA2	CA3	CA4	
<b>Mode</b>	Practical Test	Practical Test	Written Test Theory	Practical Test	Practical Examination
<b>Portion</b>	Cycle I Exercises	Cycle II Exercises	All Units	All Exercises	All Exercises
<b>Duration</b>	2 Periods	2 Periods	3 Hours	3 Hours	3 hours
<b>Exam Marks</b>	60	60	100	100	100
<b>Converted to Marks</b>	10	10	15	15	60
<b>Marks</b>	10		15	15	60
<b>Internal Marks</b>	40				
<b>Tentative Schedule</b>	7th Week	14th Week	15th Week	16th Week	

Note:

- **CA1 and CA2:** All the exercises/experiments should be completed as per the portions above and kept for the practical test. The students shall be permitted to select any one by lot for the test. The practical test should be conducted as per the scheme of evaluation as below. The marks awarded shall be converted to 10 Marks for each



1021235547	<b>ENGINE TESTING</b>	L	T	P	C
PRACTICUM		1	0	4	3

assessment test. Best of one will be considered for the internal assessment of 10 Marks.

Practical documents should be maintained for every exercise / experiment immediately after completion of the practice. The practical document should be submitted for the practical test. The same should be evaluated for 10 Marks for each exercise/experiment. The total marks awarded should be converted to 10 Marks for the practical test as per the scheme of evaluation as below.

**The details of the practical documents are to be prepared as per the instructions below.**

Each exercise / Experiment procedure, observation and calculations should be completed on the day of practice. The same shall be evaluated for 10 marks on the day or the next day of practice before the commencement of the next exercise.

This documentation can be carried out in a separate notebook or a printed manual or a file with documents. The Observation, reading, calculations, report, graphs and results should be written by the student manually in the practical documents.

The evaluated practical document should be submitted for the Practical Test. The marks scored by the students should be converted to 10 marks. The same should be included as per the allocation in the practical test.

The detailed dates of the practices and its evaluations should be maintained in the course logbook. The log book and the practical documents should be submitted for the verification by the Flying Squad and DOTE Official.

#### SCHEME OF EVALUATION

PART	DESCRIPTION	MARKS
A	Aim & Tools Required	10
B	Procedure / Observation	20
C	Report / Troubleshooting	20
TOTAL		50
D	Practical Documents (As per the portions)	10
		60



1021235547	<b>ENGINE TESTING</b>	L	T	P	C
PRACTICUM		1	0	4	3

**Cycle I:** 1, 2, 3, 4 and 5.

**Cycle II:** 6, 7, 8, 9 and 10.

- **CA 3:** Written Test for complete theory portions should be conducted for 100 Marks as per the question pattern below. The marks scored will be converted to 15 Marks for internal assessment.

**Question pattern – Written Test Theory**

Description		Marks	
Part – A	30 MCQ from the complete theory portions	30 X 1 Mark	30 Marks
Part – B	Seven Questions to be answered out of 10 Questions.	7 X 10 Marks	70 Marks
TOTAL			100 Marks

- **CA 4:** All the exercises/experiments should be completed and kept for the practical test. The students shall be permitted to select any one by lot for the test. The practical test should be conducted as per the scheme of evaluation below. After completion of all the exercises, the practical test should be conducted as per the End-Semester Examination question pattern scheme of evaluation. The marks awarded should be converted to 15 Marks for the internal assessment.



1021235547	<b>ENGINE TESTING</b>	L	T	P	C
PRACTICUM		1	0	4	3

### SCHEME OF EVALUATION

#### Model Practical Examination and End Semester Examination - Practical Exam

PART	DESCRIPTION	MARKS
A	Aim & Tools Required	10
B	Procedure / Observation	20
C	Report / Troubleshooting	20
D	Result	10
E	Written Test (Theory Portions only)	30
F	Viva Voce	10
TOTAL		100

**Note:** For the written test 30 MCQ shall be asked from the theory portions.



1021235547	<b>ENGINE TESTING</b>	L	T	P	C
PRACTICUM		1	0	4	3

### Syllabus Contents

<b>Theory Portion - Unit I</b>	
<p>IC Engine - Classification - Different parts of IC engines - Cylinder - Cylinder head - Piston - Piston rings - Connecting rod - Crankshaft - Flywheel. Governor - Types - Description. Valve and valve operating mechanisms - Spark plug - Carburetor - Fuel Pump - Fuel injector. List the engine parts, materials and functions.</p> <p>Four stroke cycle engine - Two stroke cycle engine - Compare two stroke and four stroke engine. Compare SI engine and CI engine. Compare Petrol and Diesel engines.</p> <p>Combustion of SI engine: the Spark advance, Pre-ignition, Detonation. Combustion chamber and its types.</p> <p>Combustion of CI Engines: Phases of CI engine combustion - Compression ratio - Delay period - Diesel knock.</p> <p>Port timing Diagram - Valve timing diagram.</p>	15
<p><b>Practical Exercises</b></p> <p><b>Exercise 1:</b> Identify and check the following components – cylinder block, crankshaft, connecting rod, inlet and exhaust manifolds, valve train and its components of petrol engine (four wheeler).</p> <p><b>Exercise 2:</b> Identify and check the following components – cylinder block, crankshaft, connecting rod, inlet and exhaust manifolds, valve train and its components of diesel engine (four wheeler).</p> <p><b>Exercise 3:</b> Testing the Valve spring by spring tester.</p> <p><b>Exercise 4:</b> Adjustment of valve tappet clearance (four cylinder/six-cylinder engine)</p> <p><b>Exercise 5:</b> Dismantle and Assemble engine part, piston connecting rod, cylinder head, rocker arm assembly.</p> <p><b>Exercise 6:</b> Calibrating and phasing of fuel pump through calibrating machine.</p> <p><b>Exercise 7:</b> Dismantle and Assemble engine parts such as F.I. pump, injectors, fuel filter &amp; other accessories.</p>	50



1021235547	<b>ENGINE TESTING</b>	L	T	P	C
PRACTICUM		1	0	4	3

<p><b>Exercise 8:</b> Conduct the variable speed performance test of a single-cylinder petrol engine and draw the curve. 1. BHP, IHP, FHP Vs Speed 2. Volumetric efficiency, SFC Vs Speed.</p> <p><b>Exercise 9:</b> Conduct the constant speed performance test of a single-cylinder diesel engine and draw the curve. 1. BHP, IHP, FHP Vs Speed 2. Volumetric efficiency, SFC Vs Speed.</p> <p><b>Exercise 10:</b> Prepare the heat balance sheet on a multi-cylinder petrol/diesel engine.</p>	
	Revision + Test
	Total

**Text book for Reference:**

1. A textbook of Automobile Engineering, Er.R.K.Rajput, Second edition, Laxmi Publications (P) Ltd. 2017.



1021235547	<b>ENGINE TESTING</b>	L	T	P	C
PRACTICUM		1	0	4	3

**Equipment / Facilities required**

<b>PART</b>	<b>DESCRIPTION</b>	<b>Quantity</b>
1	Diesel engine (four wheeler)	2
2	Petrol engine (four wheeler)	2
3	Fuel pump calibration machine.	1
4	Spring tester	1
5	Four cylinder/six-cylinder engine for valve tappet clearance	1
6	Four Wheel Vehicle	1
7	Single cylinder petrol engine with Load test arrangement.	01
8	Single cylinder diesel engine with Load test arrangement.	01
9	Multi-cylinder petrol / diesel engine with Heat balance test arrangement.	01
10	Spanner and Wrenches	1 Set
11	Special tools	1 Set
12	Garage equipments	As required.



1021235547	<b>ENGINE TESTING</b>	L	T	P	C
PRACTICUM		1	0	4	3

### END SEMESTER EXAMINATIONS – PRACTICAL EXAM

**Note:**

All the exercises / experiments should be completed before the Board Practical Examinations. End Semester Practical examination should be conducted for all the exercises / experiments for 100 Marks. Students will be permitted to select any one exercise by lot or question paper supplied by the DOTE Exam section shall be used.

The Practical Documents by the student should be submitted with a Bonafide Certificate.

PART	DESCRIPTION	MARKS
A	Aim & Tools Required	10
B	Procedure / Observation	20
C	Report / Troubleshooting	20
D	Result	10
E	Written Test (Theory Portions only)	30
F	Viva Voce	10
TOTAL		100

**Note:** For the written test 30 MCQ shall be asked from the theory portions.



1021235654	<b>Innovation &amp; Startup</b>	L	T	P	C
PRACTICUM		1	0	2	2

### **Introduction**

The integration of Innovation and Start-ups concept within the syllabus is testament to the forward thinking nature of educational institutions. By introducing this concept, students are provided with a solid foundation upon which they can build their skills in Innovation and Start-ups. This course can bridge the gap between theory and practice. It allows students to apply the knowledge they have acquired in a real world context, thereby enhancing their understanding and retention of the above concept. This experimental learning approach not only fosters a deeper level of engagement but also trains student with practical skills necessary to navigate the complexities of the business world. This also empowers students to become an Innovator or Entrepreneur. With necessary tools and knowledge, educational institutions are preparing the next generation of entrepreneurs to tackle the challenges and opportunities that lie ahead. This syllabus will explore the different facets of innovation, including its importance, types and strategies for fostering a culture of innovation within organizations

### **Course Objectives**

The objective of this course is to enable the students

- o To understand the concept of Innovation and Start-ups.
- o To acquire knowledge of Prototype development, IPR, Patents and Copyrights.
- o To have practical experience in preparing Business plan for Start-ups.
- o To visit the existing nearby industry to prepare a project report about the present challenges of that industry.
- o To know the different funding supports available from Government and Non-Government schemes for Start-ups.



1021235654	<b>Innovation &amp; Startup</b>	L	T	P	C
PRACTICUM		1	0	2	2

### Course Outcomes

After successful completion of this course, the students should be able to

- CO 1: Differentiate between Innovation and Start-ups
- CO 2: Explain the importance of IPR, Patents and Copyrights.
- CO 3: Describe the methodology to be adopted for preparing the Business Plan
- CO 4: Gain practical experience by Industrial training and visiting the nearby industry
- Co 5: Explore and identify various funding facilities available from Government and Non-Government Schemes for Start-ups

### Pre-requisites:

There are no specific prerequisites for this course, although a basic understanding of business and technology concepts would be beneficial.

### CO/PO Mapping

CO / PO	P01	P02	P03	P04	P05	P06	P07
<b>C01</b>	-	-	1	-	2	3	3
<b>C02</b>	-	-	1	-	2	3	3
<b>C03</b>	-	-	1	-	2	3	3
<b>C04</b>	-	-	1	-	2	3	3
<b>C05</b>	-	-	1	-	2	3	3

Legend: 3-High Correlation, 2-Medium Correlation, 1-Low Correlation



1021235654	<b>Innovation &amp; Startup</b>	L	T	P	C
PRACTICUM		1	0	2	2

### Assessment Methodology

	Continuous Assessment (40 marks)			End Semester Examination (60 marks)
	CA1	CA2	CA3	
<b>Mode</b>	Class Assessment (Unit I, II & Unit III)	Seminar Presentations (Unit IV)	Submission of Industry Visit Project Report (Unit V)	Practical Examination (Project)
<b>Duration</b>	2 hours	---	---	3 hours
<b>Exam Marks</b>	50	20	30	100
<b>Converted to</b>	10	10	20	60
<b>Marks</b>	<b>10</b>	<b>10</b>	<b>20</b>	<b>60</b>

### Continuous Assessment - 40 marks

S. No	Description	Marks
CA 1	<b>Class Assessment (50 marks) - Unit – I,II &amp; III</b> Written Examination - Theory Questions 10 questions out of 15 questions (10 x 3 marks :30 marks) 4 questions out of 6 questions (4 x 5 marks : 20 marks)	10 marks
CA 2	<b>Seminar Presentations (20 marks- each topic carries 10 marks) - Unit IV</b> Students should present any two topics with PPTs	10 marks
CA 3	Submission of Industry Visit Project Report - <b>(30 marks) - Unit V</b>	20 marks
<b>Total</b>		<b>40 marks</b>



1021235654	<b>Innovation &amp; Startup</b>	L	T	P	C
PRACTICUM		1	0	2	2

### Syllabus Contents

<b>UNIT I</b>	<b>INTRODUCTION TO INNOVATION</b>			
An Introduction to Innovation and Creativity- Innovation in current Environment - Types of Innovation - Challenges of Innovation - Steps of Innovation Management - Divergent v/s Convergent thinking - Design thinking and Entrepreneurship.				6
<b>UNIT II</b>	<b>INCUBATION CLUBS, IPR, PATENTS AND COPYRIGHTS</b>			
Idea Generation - Incubation Clubs - Prototype Development - Marketing of Innovation - Management of Innovation - Creation of IPR -Types of IPR - Patents and Copyrights - Patents in India - Technological and Non-Technological Innovation Process.				6
<b>UNIT III</b>	<b>GOVERNMENT AND NON-GOVERNMENT FUNDING SCHEMES FOR START-UPS</b>			
An introduction to Start-up - Start-ups in India - Procedure for registration of Start-ups - Business Model- Business Plan - Case Studies - Opportunities and Challenges - Funding supports from Government Schemes -MUDRA, TANSEED, NEEDS, PMEGP, UYEGP – Non-Government Schemes - CSR Fund - Angel Investors - Venture Capitalist.				6
<b>UNIT IV</b>				
All the students have to select a minimum of 2 topics from the list given below. They are expected to collect the resources with the help of faculty assigned to them to prepare PPTs for presentation				9
<ol style="list-style-type: none"> <li>1. Idea Generation.</li> <li>2. Innovation Management.</li> <li>3. Product Development.</li> </ol>				



1021235654	<b>Innovation &amp; Startup</b>	L	T	P	C
PRACTICUM		1	0	2	2

<p>4. Business Model Innovation.</p> <p>5. Organizational Culture and Change Management.</p> <p>6. Leadership and Innovation.</p> <p>7. Barriers to Innovation.</p> <p>8. Innovation Marketing.</p> <p>9. E-Commerce success stories (any one).</p> <p>10. Role of Start-ups in Higher Education.</p> <p>11. Professional Networking in Building Brands.</p> <p>12. How to start a start-up in India.</p>		
<b>UNIT V</b>	<b>EXPOSURE TO INDUSTRY</b>	
<p>All the students should visit and study the nearby industries, incubation centres, start-ups etc., and select any one to prepare a project report which covers the Name of the Industry/Organization, Introduction of the Industry, Type of the Industry, Scope of the Industry, Plant Layout and Location, Details of Plant and Machineries, Process flow chart, Manufacturing Methods, Process of Manufacturing, Product Manufacturing, Quality Control, Marketing, Product selling - Conclusion.</p>		<b>18</b>
<b>Total</b>		<b>45</b>



1021235654	<b>Innovation &amp; Startup</b>	L	T	P	C
PRACTICUM		1	0	2	2

### End Semester Examination - Project Exam

Students should be assessed for 100 Marks both by the internal examiner and external examiner appointed by the Chairman Board of Examinations.

### Detailed Allocation of Marks

S. No	Description	Marks
Part A	Written Examination – Unit –I,II & III Theory Questions	45
	i) 10 questions out of 15 questions (10 x 3 marks = 30 marks)	
	ii) 3 questions either or pattern (3 x 5 marks = 15 marks)	
Part B	i) Presentation of Industry Visit Project Report	25
	ii) Interaction and Evaluation	30
<b>TOTAL</b>		<b>100</b>



1021235773	<b>Industrial Training</b>	Summer Vacation	C
Internship			2

### **Introduction**

Industrial training is a crucial component of the diploma engineering curriculum, designed to bridge the gap between theoretical knowledge and practical application. Typically conducted during vacation periods, this two-week training program provides students with hands-on experience in their respective engineering fields. The primary objectives are to enhance practical skills, familiarize students with industry standards, and prepare them for future employment.

Two-week industrial training during vacation periods is an invaluable part of diploma engineering education. It not only equips students with practical skills but also provides a comprehensive understanding of the industry, preparing them for successful engineering careers.

### **Objectives**

1. **Practical Exposure:** Students gain direct exposure to real-world engineering practices, tools, and technologies.
2. **Skill Enhancement:** The training helps in developing technical and soft skills that are essential for professional growth.
3. **Industry Insight:** Students learn about the working environment, operational procedures, and challenges faced by industries.
4. **Professional Networking:** The training offers opportunities to interact with industry professionals, which can be beneficial for career prospects.
5. **Application of Knowledge:** It allows students to apply classroom knowledge to solve practical problems, enhancing their understanding and retention of engineering concepts.

### **Structure of the Training Program**

- **Orientation:** Introduction to the company, its operations, and safety protocols.
- **Project Assignment:** Students are assigned specific projects or tasks relevant to their field of study.
- **Supervision and Mentorship:** Industry professionals guide and mentor students throughout the training.



1021235773	<b>Industrial Training</b>	Summer Vacation	C
Internship			2

- Skill Development Workshops: Sessions on technical skills, software tools, and industry best practices.
- Assessment and Feedback: Performance evaluations and constructive feedback to help students improve.

### **Benefits for Students**

- Enhanced Employability: Practical experience makes students more attractive to potential employers.
- Confidence Building: Working in a real-world setting boosts confidence and professional demeanor.
- Clarified Career Goals: Exposure to various roles and responsibilities helps students define their career paths.

### **Course Outcomes**

CO 1: Demonstrate proficiency in using industrial machinery, tools, and software.

CO 2: Able to identify, analyze, and solve engineering problems using industry-standard methods and practices.

CO 3: Gain a comprehensive understanding of industrial manufacturing processes, quality control, and safety practices.

CO 4: Exhibit improved communication, teamwork, and professional behavior in an industrial setting.

CO 5: Apply theoretical concepts learned in their coursework to practical engineering tasks and projects.

### **Duties Responsibilities of the Faculty Mentor.**

One faculty mentor should be assigned for every 30 students by the HOD / Principal. Faculty mentors shall play a crucial role in overseeing and guiding students during their industrial training program in Diploma engineering.

### **Pre-Training Responsibilities:**

1. Orientation and Preparation:
  - Conduct orientation sessions to familiarize students with the objectives, expectations, and guidelines of the industrial training program.



1021235773	<b>Industrial Training</b>	Summer Vacation	C
Internship			2

- Assist students in understanding the importance of industrial training in their academic and professional development.
2. Placement Coordination:
    - Collaborate with the placement cell or industry liaison office to secure suitable training placements for students that align with their academic specialization and career interests.
    - Facilitate communication between the institution and host organizations to ensure smooth coordination of training arrangements.
  3. Training Plan Development:
    - Help students develop a detailed training plan outlining learning objectives, tasks, and expected outcomes for the training period.
    - Guide students in setting SMART (Specific, Measurable, Achievable, Relevant, Time-bound) goals for their training experience.

**During Training Responsibilities:**

4. Monitoring and Support:
  - Regularly monitor the progress of students during their industrial training. Maintain communication with both students and industry supervisors to track performance and address any issues that may arise.
  - Provide ongoing support and guidance to students, offering advice on technical challenges, professional conduct, and workplace etiquette.
5. Technical Guidance:
  - Offer technical guidance and mentorship related to the specific engineering discipline or specialization of the students. Help them apply theoretical knowledge to practical situations encountered in the industry.
6. Problem-Solving Assistance:
  - Assist students in overcoming obstacles or challenges encountered during their training. Encourage them to develop problem-solving skills and resilience in real-world engineering scenarios.



1021235773	<b>Industrial Training</b>	Summer Vacation	C
Internship			2

7. Feedback and Evaluation:

- Provide constructive feedback on students' performance based on reports, assessments, and observations gathered from industry supervisors.
- Evaluate students' achievements in relation to their training objectives and competencies developed during the program.

**Post-Training Responsibilities:**

8. Reflection and Debriefing:

- Conduct debriefing sessions with students to reflect on their training experiences, discuss lessons learned, and identify areas for further improvement.
- Help students articulate their learning outcomes and how these experiences contribute to their professional growth.

9. Documentation and Reporting:

- Ensure comprehensive documentation of students' training activities, achievements, and feedback received from industry supervisors.
- Prepare reports summarizing students' performance and submit these to relevant departments or committees for review and assessment.

10. Career Counseling:

- Provide career guidance and counseling to students based on their industrial training experiences. Assist them in leveraging these experiences for future job applications or further academic pursuits.

11. Continuous Improvement:

- Collaborate with industry partners to continuously improve the quality and relevance of the industrial training program.
- Incorporate feedback from students and industry supervisors to enhance the effectiveness of future training placements.

By fulfilling these duties and responsibilities, faculty mentors contribute significantly to the overall educational experience and professional development of Diploma engineering students during their industrial training program.



1021235773	<b>Industrial Training</b>	Summer Vacation	C
Internship			2

### Instructions to the students

#### Before Starting Industrial Training:

##### 1. Orientation and Preparation:

- Attend orientation sessions conducted by the institution or faculty mentors to understand the objectives, expectations, and guidelines of the industrial training program.
- Familiarize yourself with the specific policies, procedures, and safety regulations of the host organization where you will be undergoing training.

##### 2. Setting Goals:

- Set clear and specific goals for your industrial training period. Define what skills, knowledge, and experiences you aim to gain during this time.
- Discuss your goals with your faculty mentor and seek their guidance in developing a training plan that aligns with your career aspirations.

##### 3. Professional Attire and Conduct:

- Dress appropriately and professionally according to the standards of the industry and host organization.
- Maintain a positive attitude, demonstrate punctuality, and adhere to workplace etiquette and norms.

#### During Industrial Training:

##### 4. Learning and Engagement:

- Actively engage in all assigned tasks and projects. Seek opportunities to learn new skills and technologies relevant to your field of study.
- Take initiative in asking questions, seeking clarification, and participating in discussions with supervisors and colleagues.

##### 5. Adaptability and Flexibility:

- Adapt to the work environment and demonstrate flexibility in handling various responsibilities and challenges that arise during your training.
- Be open to different roles and tasks assigned to you, as this will broaden your experience and skill set.



1021235773	<b>Industrial Training</b>	Summer Vacation	C
Internship			2

6. Professionalism and Communication:

- Communicate effectively with supervisors, colleagues, and clients as required. Practice clear and concise verbal and written communication.
- Demonstrate professionalism in all interactions, respecting confidentiality, and adhering to company policies and procedures.

7. Safety and Compliance:

- Prioritize safety at all times. Familiarize yourself with safety protocols, procedures, and emergency exits in the workplace.
- Follow all safety guidelines and regulations to ensure your well-being and that of others around you.

**After Completing Industrial Training:**

8. Reflection and Documentation:

- Reflect on your training experience. Evaluate what you have learned, the challenges you faced, and how you have grown professionally.
- Maintain a journal or log documenting your daily activities, achievements, and lessons learned during the training period.

9. Feedback and Evaluation:

- Seek feedback from your industry supervisor and faculty mentor on your performance and areas for improvement.
- Use constructive feedback to enhance your skills and competencies for future career opportunities.

10. Career Planning:

- Use your industrial training experience to inform your career planning and decision-making process.
- Discuss your career goals and aspirations with your faculty mentor or career counselor for guidance on next steps after completing your diploma.

By following these instructions, Diploma engineering students can make the most of their industrial training experience, gain valuable insights into their chosen field, and prepare themselves effectively for future professional endeavors.



1021235773	<b>Industrial Training</b>	Summer Vacation	C
Internship			2

### **Attendance Certification**

Every student has to get their attendance certified by the industrial supervisor in the prescribed form supplied to them. Students have also to put their signature on the form and submit it to the institution faculty mentor.

### **Training Reports**

The students have to prepare reports: The report in the form of a diary to be submitted to the concerned faculty mentor of the institution. This will be reviewed while awarding Internal assessment.

### **Industrial Training Diary**

Students are required to maintain the record of day-to-day work done. Such a record is called Industrial training Diary. Students have to write this report regularly. All days for the week should be accounted for clearly giving attendance particulars (Presence, absence, Leave, Holidays etc.). The concern of the Industrial supervisor is to periodically check these progress reports.

In addition to the diary, students are required to submit a comprehensive report on training with details of the organisation where the training was undergone after attestation by the supervisors. The comprehensive report should incorporate study of plant / product / process / construction along with intensive in-depth study on any one of the topics such as processes, methods, tooling, construction and equipment, highlighting aspects of quality, productivity and system. The comprehensive report should be completed in the last week of Industrial training. Any data, drawings etc. should be incorporated with the consent of the Organisation.

### **Scheme of Evaluation**

#### **Internal Assessment**

Students should be assessed for 40 Marks by industry supervisor and polytechnic faculty mentor for the Internal Assessment.

Sl. No.	Description	Marks
---------	-------------	-------



1021235773	<b>Industrial Training</b>	Summer Vacation	C
Internship			2

A	Punctuality and regularity. (Attendance)	10
B	Level / proficiency of practical skills acquired. Initiative in learning / working at site	10
C	Self expression / communication skills. Interpersonal skills / Human Relation.	10
D	Report and Presentation.	10
Total		40

### End Semester Examination - Project Exam

Students should be assessed for 100 Marks both by the internal examiner and external examiner appointed by the Chairman Board of Examinations after the completion of industrial training. The marks scored will be converted to 60 marks for the End Semester Examination.

#### Scheme of Evaluation

Sl. No.	Description	Marks
A	Daily Activity Report and Attendance certificate.	20
B	Comprehensive report on Internship, Relevant Internship Certificate from the concerned department.	30
C	Presentation by the student at the end of the Internship.	30
D	Viva Voce	20
Total		100



2023235773	<b>Mini Project (Sandwich Course Only)</b>	L	T	P	C
PROJECT		0	0	4	2

### Introduction

Every student must do one mini project in the sandwich diploma program. Students can do their project in Industry or R&D Lab or in-house or a combination of any two for the partial fulfillment for the award of Diploma in Engineering.

For the project works, the Department will constitute a three-member faculty committee to monitor the progress of the project and conduct reviews regularly.

If the projects are done in-house, the students must obtain the bonafide certificate for project work from the Project supervisor and Head of the Department, at the end of the semester. Students who have not obtained the bonafide certificate are not permitted to appear for the Project Viva Voce examination.

For the projects carried out in Industry, the students must submit a separate certificate from Industry apart from the regular bonafide certificate mentioned above. For Industry related projects there must be one internal faculty advisor / Supervisor from Industry (External), this is in addition to the regular faculty supervision.

The final examination for project work will be evaluated based on the final report submitted by the project group **of not exceeding four students**, and the viva voce by an external examiner.

### Objectives

Academic project work plays a crucial role in the education of Diploma in Engineering students, as it helps them apply theoretical knowledge to practical situations and prepares them for real-world engineering challenges.

- **Integration of Knowledge:** Consolidate and integrate theoretical knowledge acquired in coursework to solve practical engineering problems.
- **Skill Development:** Enhance technical skills related to the specific field of engineering through hands-on experience and application.
- **Problem-Solving Abilities:** Develop critical thinking and problem-solving abilities by addressing complex engineering issues within a defined scope.
- **Project Management:** Gain experience in project planning, execution, and management, including setting objectives, timelines, and resource allocation.



2023235773	<b>Mini Project (Sandwich Course Only)</b>	L	T	P	C
PROJECT		0	0	4	2

- **Teamwork and Collaboration:** Foster teamwork and collaboration by working in multidisciplinary teams to achieve project goals and objectives.
- **Research Skills:** Acquire research skills by conducting literature reviews, gathering relevant data, and applying research methodologies to investigate engineering problems.
- **Innovation and Creativity:** Encourage innovation and creativity in proposing and developing engineering solutions that may be novel or improve upon existing methods.
- **Communication Skills:** Improve communication skills, both oral and written, by presenting project findings, writing technical reports, and effectively conveying ideas to stakeholders.
- **Ethical Considerations:** Consider ethical implications related to engineering practices, including safety, environmental impact, and societal concerns.
- **Professional Development:** Prepare for future professional roles by demonstrating professionalism, initiative, and responsibility throughout the project lifecycle.

### Course Outcomes

**CO 1:** Demonstrate the ability to apply theoretical concepts and principles learned in coursework to solve practical engineering problems encountered during the project.

**CO 2:** Develop and enhance technical skills specific to the field of engineering relevant to the project, such as design, analysis, simulation, construction, testing, and implementation.

**CO 3:** Apply critical thinking and problem-solving skills to identify, analyze, and propose solutions to engineering challenges encountered throughout the project lifecycle.

**CO 4:** Acquire project management skills by effectively planning, organizing, and executing project tasks within defined timelines and resource constraints.

**CO 5:** Improve communication skills through the preparation and delivery of project reports, presentations, and documentation that effectively convey technical information to stakeholders.



2023235773	<b>Mini Project (Sandwich Course Only)</b>	L	T	P	C
PROJECT		0	0	4	2

**Important points to consider to select the mini project.**

- Selecting a project work in Diploma Engineering is a significant decision that can greatly influence your learning experience and future career prospects.
- Choose a project that aligns with your career aspirations and interests within the field of engineering. Consider how the project can contribute to your professional development and future opportunities.
- Ensure the project aligns with your coursework and specialization within the Diploma program. It should complement and build upon the knowledge and skills you have acquired in your studies.
- Evaluate the scope of the project to ensure it is manageable within the given timeframe, resources, and constraints. Avoid projects that are overly ambitious or impractical to complete effectively.
- Assess the availability of resources needed to conduct the project, such as equipment, materials, laboratory facilities, and access to relevant software or tools. Lack of resources can hinder project progress.
- Select a project that genuinely interests and motivates you. A project that captures your curiosity and passion will keep you engaged and committed throughout the project duration.
- Consider the availability and expertise of faculty advisors or industry mentors who can provide guidance and support throughout the project. Effective mentorship is crucial for success.
- Clearly define the learning objectives and expected outcomes of the project. Ensure that the project will help you achieve specific learning goals related to technical skills, problem-solving, and professional development.
- Look for opportunities to propose innovative solutions or explore new methodologies within your project. Projects that encourage creativity can set you apart and enhance your learning experience.



2023235773	<b>Mini Project (Sandwich Course Only)</b>	L	T	P	C
PROJECT		0	0	4	2

- Consider ethical implications related to the project, such as safety protocols, environmental impact, and compliance with ethical guidelines in research and engineering practices.
- Evaluate whether the project offers opportunities for collaboration with peers, experts from other disciplines, or industry partners. Interdisciplinary projects can broaden your perspective and enhance your teamwork skills.
- Consider the potential impact of your project on society or the engineering community. Projects that address significant challenges or contribute to social good can be highly fulfilling and make a meaningful difference.

By carefully considering these points, Diploma Engineering students can make informed decisions when selecting project work that not only enhances their academic learning but also prepares them for successful careers in engineering.

#### **Duties Responsibilities of the internal faculty advisor.**

Each group should have an internal faculty advisor assigned by the HOD/Principal.

- The project should be approved by the project monitoring committee constituted by the Chairman Board of Examinations.
- The project should be selected in the sixth semester itself. Each project shall have a maximum of four students in the project group.
- Provide comprehensive academic advising to help in the selection of appropriate project that align with their interests and career goals.
- Offer expertise and feedback to ensure rigorous methodology, innovative approaches, and meaningful contributions to the field.
- Assist in developing technical and professional skills through hands-on projects, laboratory work, and practical applications of theoretical knowledge.
- Provide personal mentorship, fostering a supportive relationship that encourages growth, resilience, and a positive academic experience.
- Facilitate connections between students and industry professionals, alumni, and other relevant networks to enhance their professional opportunities and industry exposure.



2023235773	<b>Mini Project (Sandwich Course Only)</b>	L	T	P	C
PROJECT		0	0	4	2

- Ensure students have access to necessary resources, including research materials, lab equipment, software, and academic literature.
- Regularly monitor and evaluate the progress of the project, providing constructive feedback and guidance to help them stay on track and achieve their goals.
- Instill and uphold high ethical and professional standards, encouraging students to practice integrity and responsibility in their work.
- Assist in preparing progress reports, writing recommendation letters, and facilitating grant applications.
- Organize and participate in workshops, seminars, and other educational events that enhance the learning experience and professional development .
- Address any issues or conflicts that arise, providing mediation and support to ensure a positive and productive academic environment.

**Instructions to the students.**

- Regularly meet with your internal faculty advisor for guidance on academic progress, research projects, and career planning. Be proactive in seeking advice and support from your faculty advisor.
- Use planners, calendars, and task management tools to keep track of assignments, project deadlines, and study schedules. Prioritize tasks to manage your time efficiently.
- Take advantage of opportunities to participate in projects and hands-on activities. These experiences are crucial for applying your theoretical knowledge and gaining practical skills.
- Focus on improving essential professional skills such as communication, teamwork, problem-solving, and leadership. Participate in workshops and seminars that enhance these competencies.
- Actively seek networking opportunities through industry events, seminars, and meetings. Establish connections with peers, alumni, and professionals in your field to build a strong professional network.



2023235773	<b>Mini Project (Sandwich Course Only)</b>	L	T	P	C
PROJECT		0	0	4	2

- Seek internships, co-op programs, or part-time jobs related to your field of study. Real-world experience is invaluable for understanding industry practices and enhancing your employability.
- Uphold high ethical standards in all your academic and professional activities. Practice integrity, honesty, and responsibility. Adhere to the ethical guidelines and standards set by your institution and the engineering profession.
- Adopt a mindset of lifelong learning. Stay updated with the latest developments and trends in engineering by reading industry journals, attending conferences, and taking additional courses.

#### **Documents to be submitted by the student for a project.**

Submit a printed report of your project work along with the fabrication model / analysis report for the End Semester Examination.

#### **Rubrics for Mini Project Work**

Sl. No.	Topics	Description
1	Objectives	Clearly defined and specific objectives outlined. Objectives align with the project's scope and purpose.
2	Literature Review	Thorough review of relevant literature. Identification of gaps and justification for the project's contribution.
3	Research Design and Methodology	Clear explanation of the research design. Appropriateness and justification of chosen research methods.



2023235773	<b>Mini Project (Sandwich Course Only)</b>	L	T	P	C
PROJECT		0	0	4	2

4	Project Management	Adherence to project timeline and milestones. Effective organization and planning evident in the project execution.
5	Documentation	Comprehensive documentation of project details. Clarity and completeness in recording methods, results, and challenges.
6	Presentation Skills	Clear and articulate communication of project findings. Effective use of visuals, if applicable.
7	Analysis and Interpretation	In-depth analysis of data. Clear interpretation of results in the context of research questions.
8	Problem-Solving	Demonstrated ability to identify and address challenges encountered during the project. Innovative solutions considered where applicable.
9	Professionalism and Compliance	Adherence to ethical standards in research. Compliance with project guidelines and requirements.
10	Quality of Work	Overall quality and contribution of the project to the field. Demonstrated effort to produce high-quality work.



2023235773	<b>Mini Project (Sandwich Course Only)</b>	L	T	P	C
PROJECT		0	0	4	2

### SCHEME OF EVALUATION

The mark allocation for Internal and End Semester Viva Voce are as below.

<b>Internal Mark Split (40 Marks)*</b>		
Review 1 (10 Marks)	Review 2 (15 Marks)	Review 3 (15 marks)
Committee: 5 Marks. Supervisor: 5 Marks	Committee: 7.5 Marks Supervisor: 7.5 Marks	Committee: 7.5 Marks Supervisor: 7.5 Marks

Note: \* The rubrics should be followed for the evaluation of the internal marks during reviews.

### END SEMESTER EXAMINATION - Project Exam

The performance of each student in the project group would be evaluated in a viva voce examination conducted by a committee consisting of an external examiner and the Department project supervisor and an internal examiner.

<b>End Semester (100)#</b>			
Record (20 Marks)	Presentation (20 Marks)	Viva Voce (20 Marks)	Model / Analysis Report (40 Marks)
External: 10 Internal: 5 Supervisor: 5	External: 10 Internal: 5 Supervisor: 5	External: 10 Internal: 5 Supervisor: 5	External: 20 Internal: 10 Supervisor: 10

# The marks scored will be converted to 60 Marks.



1021236110	<b>Industrial Management and Transport Engineering</b>	L	T	P	C
THEORY		3	0	0	3

### **Introduction**

Automobile technicians can play an important part in the management of transportation organizations. The transportation business offered numerous job prospects for Diploma in Automobile Engineers, including service engineer, fleet supervisor, and depot supervisor. The car mechanic must have a thorough understanding of the Motor Vehicle Act, rules, record keeping, vehicle estimation and valuation, and standard operating procedures. This subject covers management principles, personnel management, financial management, and material management.

### **Course Objectives**

- To learn the Principles of Management and Personnel Management.
- To study about the Financial Management and Material Management
- To learn the Goods and Passenger Transport operations.
- To study about the Motor Vehicles act.
- To learn the Principles of Engineering ethics and Human values.

### **Course Outcomes**

On successful completion of this course, the student will be able to

CO1: Understand the Principles of Management and Personnel Management

CO2: Understand the Financial Management and Material Management

CO3: Understand about the Goods and Passenger transport operations.

CO4: Understand about the Motor vehicles act, Taxation and Insurance.

CO5: Understand about the Engineering Ethics and Human Values

### **Pre-requisites:**

Familiarity with fundamental sciences



1021236110	<b>Industrial Management and Transport Engineering</b>	L	T	P	C
THEORY		3	0	0	3

### CO/PO Mapping

CO / PO	P01	P02	P03	P04	P05	P06	P07
<b>C01</b>	1	2	-	-	1	3	2
<b>C02</b>	1	2	-	-	1	3	2
<b>C03</b>	1	2	-	-	2	3	2
<b>C04</b>	1	1	-	-	1	1	2
<b>C05</b>	1	1	-	-	3	3	3

Legend: 3-High Correlation, 2-Medium Correlation, 1-Low Correlation

### Instructional Strategy:

Engage and Motivate: Instructors should actively engage students to increase their learning confidence.

Interactive learning: Arrange interactive student activities and make use of demonstrations to create a dynamic learning environment.



1021236110	<b>Industrial Management and Transport Engineering</b>	L	T	P	C
THEORY		3	0	0	3

### Assessment Methodology

	Continuous Assessment (40 marks)				End Semester Examination (60 marks)
	CA1	CA2	CA3	CA4	
<b>Mode</b>	Written test (Two units)	Written test (Another Two units)	Quiz MCQ (Online / Offline)	Model Examination	Written Examination
<b>Duration</b>	2 Periods	2 Periods	1 Hour	3 Hours	3 Hours
<b>Exam Marks</b>	50	50	60	100	100
<b>Converted to</b>	15	15	5	20	60
<b>Marks</b>	15		5	20	60
<b>Tentative Schedule</b>	6th Week	12th Week	13-14th Week	16th Week	

**CA1 and CA2:** Assessment written test should be conducted for 50 Marks for two units. The marks scored will be converted to 15 Marks. Best of one will be considered for the internal assessment of 15 Marks.

CA1 and CA2, Assessment test should be conducted for two units as below.

- Answer any five questions (5 X 10 Marks = 50 Marks).
- Eight questions will be asked, students should write Five questions. Each unit Four questions can be asked. Each question may have subdivisions. Maximum two subdivisions shall be permitted.



1021236110	<b>Industrial Management and Transport Engineering</b>	L	T	P	C
THEORY		3	0	0	3

**CA3:** 60 MCQ can be asked by covering the entire portion. It may be conducted by Online /Offline. The answer scripts of every student (online / offline) for this assessment should be kept for records and future verification. The marks scored should be converted to 5 marks for the internal assessment

**CA4:** Model examination should be conducted as per the end-semester question pattern. The marks should be converted to 20 marks for the internal assessment.

**Question Pattern:**

Answer Ten questions by selecting two questions from each unit. Each question carries 10 marks each.

Four questions will be asked from every unit, students should write any two questions. The question may have two subdivisions only.



1021236110	<b>Industrial Management and Transport Engineering</b>	L	T	P	C
THEORY		3	0	0	3

### Theory Contents

Unit I	<b>PRINCIPLES OF MANAGEMENT AND PERSONNEL MANAGEMENT</b>	
1.1: Principles of Management: Definition of Management, Administration and Organization – F.W. Taylor’s and Henry Fayol’s Principles of Management – Functions of Manager – Leadership and its types. Motivation - Positive and Negative motivation. Types of Organization – Taylor’s Pure functional type – Line and staff and committee type. Modern Management Techniques: Management Information Systems – Strategic management – SWOT Analysis - Business Process Re-engineering (BPR) – Activity Based Management (ABM).	1.2: Personnel Management: Responsibility of Human Resource Management – Selection procedure – Training of workers – Apprentice Training – On the Job Training. Job evaluation and Merit rating – objectives and importance.	7
Unit II	<b>FINANCIAL MANAGEMENT AND MATERIAL MANAGEMENT</b>	
2.1: Financial Management: Fixed Capital and Working Capital – Resources of capital – Shares - Debentures – Public deposits, Factory costing – Direct cost – Indirect cost – Factory overhead – Fixation of Selling price of a product – Profit. Depreciation – Causes.	2.2: Material Management: Objectives of Good stock control system – ABC analysis of inventory – Procurement and consumption cycle – Minimum Stock, Lead Time, Reorder Level - Economic order quantity – supply chain management - Purchasing procedure – Store keeping – Bin card.	7



1021236110	<b>Industrial Management and Transport Engineering</b>	L	T	P	C
THEORY		3	0	0	3

<b>Unit III</b>	<b>GOODS TRANSPORT AND PASSENGER TRANSPORT</b>	
3.1: Goods Transport: Simple layout of Garages and depot for Goods Transport vehicle – Scheduling of goods transport – Log sheet, way bills and other documents. Transhipments and subcontracting - Storage & transportation of petroleum products.	3.2: Passenger Transport: Administrative set up of a passenger Transport organization, traffic investigation to improve services – peak hour demands – Application of C.P.M in evaluation of shortest operating distance of vehicle. Classification of vehicles: Express, LSS and Relief services. Fare structure, Fare table calculation, and Fare collection methods – drivers and conductors duty schedules – Ticket system, trip sheet	7
<b>Unit IV</b>	<b>MOTOR VEHICLES ACT, TAXATION AND INSURANCE</b>	
4.1: Motor Vehicles Act: Motor Vehicles Act - Definition – Licensing of Drivers and Conductors - Procedure for registering a new vehicle - Fitness Certificate - Inspection of Accidents and Recording –Permit: Public service vehicle permit - Goods carriage permit - National Permit - Contract carriage permit.	4.2: Taxation: Structure - Method of laying taxation - Goods vehicle taxation - Passenger vehicle taxation - Tax exemption - One / Lifetime taxation.	7
4.3: Insurance: Types of Insurance - accident claims and settlement - duty of driver in case of accident.		



1021236110	<b>Industrial Management and Transport Engineering</b>	L	T	P	C
THEORY		3	0	0	3

Unit V	ENGINEERING ETHICS AND HUMAN VALUES
5.1: Engineering Ethics Definition - Engineering Ethics - Personal and Business ethics - Duties and Rights - Engineering as a profession – Core qualities of professional practitioners - Code of ethics - Procedure for solving ethical conflicts – Ethical Judgment - Engineers as Managers, Consultants and Leaders - Environmental ethics - Computer ethics - Intellectual Property Rights (IPRs)	7
5.2: Human values Morals – Values – Integrity - Service Learning – Civic Virtue - Respect for others - Living peacefully - Caring – Sharing –Honesty - Courage - Valuing time - Co-operation - Commitments – Empathy - Self-confidence – Character - Stress management.	
	TEST + REVISION 10
	TOTAL HOURS 45

#### Suggested List of Students Activity:

- Students will give presentations or hold seminars on any current technological developments related to the subject.
- Periodic class quizzes are given on a weekly / fortnightly basis depending on the course.

#### Text book for Reference:

1. O.P.Khanna, Industrial Engineering and Management, Revised Edition – 2004, Dhanpat Rai, Publications(P)Ltd.
2. T.R.Banga & S.C.Sharma, Engineering Economics and Management, McGraw Hill.
3. Heinz Wehrich, Harold Koontz, Management, A global perspective, McGraw Hill international edition 1994.
4. Joseph L.Massie, Essentials of Management, 4th Edition, Prentice-Hall of India.
5. Goods vehicle Operation– Dunbar.
6. Bus Operation – Dunbar.
7. Tamilnadu Motor Vehicle Act 1989.



1021236110	<b>Industrial Management and Transport Engineering</b>	L	T	P	C
THEORY		3	0	0	3

8. John Duke - Fleet Management – McGraw-Hill Co, USA -1984
9. S.Chandran, Organizational Behaviours, Vikas Publishing House Pvt. Ltd. Latest
10. M.Govindarajan and S.Natarajan ,Principles of Management ,Prentce Hall of India Pvt.Ltd. New Delhi.Latest.
11. Charles B. Fledderman, Engineering ethics, pearson prentice hall, New Jersey, 2004.

**Web-based/Online Resources:**

Topic	Website	Link
Industrial Engineering	NPTEL	<a href="https://nptel.ac.in/courses/112/107/112107142/">https://nptel.ac.in/courses/112/107/112107142/</a>
Ethics in Engineering Practice	NPTEL	<a href="https://nptel.ac.in/courses/110/105/110105097/">https://nptel.ac.in/courses/110/105/110105097/</a>
Humanities and Social Sciences - Exploring Human Values	NPTEL	<a href="https://nptel.ac.in/courses/109/104/109104068/">https://nptel.ac.in/courses/109/104/109104068/</a>

**END SEMESTER QUESTION PATTERN - THEORY EXAM**

**Duration: 3 Hrs.**

**Max. Marks: 100**

**Note:** Answer Ten questions by selecting two questions from each unit. Each question carries 10 marks each.

**Instruction to the Question Setters**

Four questions will be asked from every unit, students should write any two questions for 10 marks. The question may have two subdivisions only.



1021236241	<b>VEHICLE TESTING</b>	L	T	P	C
PRACTICUM		1	0	4	3

### **Introduction**

This course offers a comprehensive exploration of practical methodologies and techniques for evaluating the performance, safety, and efficiency of vehicles. Through a combination of theoretical instruction and hands-on experimentation, students will gain practical skills in conducting various tests and measurements on vehicles. The Vehicle Testing Laboratory course offers students the opportunity to find out the functionality of vehicles and engage in laboratory experiments. Students will develop essential skills in data collection, analysis, and interpretation, preparing them for careers in the automotive engineering field.

### **Course Objectives**

The objective of this course is to enable the student

1. To educate students on the aspects of maintenance of vehicles and subsystems.
2. To make the students understand the clutch and braking system.
3. To impart knowledge on engine maintenance and services.
4. To diagnose the electrical system of a vehicle.
5. To understand the wheel alignment system.

### **Course Outcomes**

On successful completion of this course, the student will be able to

- C01: Understand the importance of maintenance.
- C02: Gain knowledge upon clutch, brake and hand brake lever.
- C03: Analyze the engine fault in the vehicle system.
- C04: Gain knowledge on the electrical systems and its circuit.
- C05: Demonstrate to align wheel for four wheelers.

### **Pre-requisites**

NIL



1021236241	<b>VEHICLE TESTING</b>	L	T	P	C
PRACTICUM		1	0	4	3

### CO/PO Mapping

CO / PO	P01	P02	P03	P04	P05	P06	P07
<b>C01</b>	1	-	-	1	-	1	-
<b>C02</b>	1	1	-	1	-	1	-
<b>C03</b>	1	1	-	1	-	1	-
<b>C04</b>	1	1	-	1	-	1	-
<b>C05</b>	1	-	-	1	-	1	-

Legend: 3-High Correlation, 2-Medium Correlation, 1-Low Correlation

### Instructional Strategy:

- Engage and Motivate: Instructors should actively engage students to boost their confidence.
- Real-World Relevance: Incorporate relatable, real-life examples and engineering applications to help students understand and appreciate course concepts.
- Interactive Learning: Utilize demonstrations and plan interactive student activities for an engaging learning experience.
- Application-Based Learning: Employ a theory-demonstrate-practice-activity strategy throughout the course to ensure outcome-driven learning and employability.



1021236241	<b>VEHICLE TESTING</b>	L	T	P	C
PRACTICUM		1	0	4	3

**Assessment Methodology:**

	Continuous Assessment (40 marks)				End Semester Examination (60 marks)
	CA1	CA2	CA3	CA4	
<b>Mode</b>	Practical Test	Practical Test	Written Test Theory	Practical Test	Practical Examination
<b>Portion</b>	Cycle I Exercises	Cycle II Exercises	All Units	All Exercises	All Exercises
<b>Duration</b>	2 Periods	2 Periods	3 Hours	3 Hours	3 hours
<b>Exam Marks</b>	60	60	100	100	100
<b>Converted to Marks</b>	10	10	15	15	60
<b>Marks</b>	10		15	15	60
<b>Tentative Schedule</b>	7th Week	14th Week	15th Week	16th Week	

Note:

- **CA1 and CA2:** All the exercises/experiments should be completed as per the portions above and kept for the practical test. The students shall be permitted to select any one by lot for the test. The practical test should be conducted as per the scheme of evaluation as below. The marks awarded shall be converted to 10 Marks for each assessment test. Best of one will be considered for the internal assessment of 10 Marks.

Practical documents should be maintained for every exercise / experiment immediately after completion of the practice. The practical document should be submitted for the practical test. The same should be evaluated for 10 Marks for each exercise/experiment.



1021236241	<b>VEHICLE TESTING</b>	L	T	P	C
PRACTICUM		1	0	4	3

The total marks awarded should be converted to 10 Marks for the practical test as per the scheme of evaluation as below.

**The details of the practical documents are to be prepared as per the instructions below.**

Each exercise / Experiment procedure, observation and calculations should be completed on the day of practice. The same shall be evaluated for 10 marks on the day or the next day of practice before the commencement of the next exercise.

This documentation can be carried out in a separate notebook or a printed manual or a file with documents. The Observation, reading, calculations, report, graphs and results should be written by the student manually in the practical documents.

The evaluated practical document should be submitted for the Practical Test. The marks scored by the students should be converted to 10 marks. The same should be included as per the allocation in the practical test.

The detailed dates of the practices and its evaluations should be maintained in the course logbook. The log book and the practical documents should be submitted for the verification by the Flying Squad and DOTE Official.

#### SCHEME OF EVALUATION

PART	DESCRIPTION	MARKS
A	Aim & Tools Required	10
B	Procedure / Observation	20
C	Report / Troubleshooting	20
TOTAL		50
D	Practical Documents (As per the portions)	10
		60

**Cycle I:** 1, 2, 3, 4 and 5

**Cycle II:** 6, 7, 8, 9 and 10.



1021236241	<b>VEHICLE TESTING</b>	L	T	P	C
PRACTICUM		1	0	4	3

- **CA 3:** Written Test for complete theory portions should be conducted for 100 Marks as per the question pattern below. The marks scored will be converted to 15 Marks for internal assessment.

#### Question pattern – Written Test Theory

Description		Marks	
Part – A	30 MCQ from the complete theory portions	30 X 1 Mark	30 Marks
Part – B	Seven Questions to be answered out of 10 Questions.	7 X 10 Marks	70 Marks
TOTAL			100 Marks

- **CA 4:** All the exercises/experiments should be completed and kept for the practical test. The students shall be permitted to select any one by lot for the test. The practical test should be conducted as per the scheme of evaluation below. After completion of all the exercises, the practical test should be conducted as per the End Semester Examination question pattern scheme of evaluation. The marks awarded should be converted to 15 Marks for the internal assessment.

#### SCHEME OF EVALUATION

##### Model Practical Examination and End Semester Examination - Practical Exam

PART	DESCRIPTION	MARKS
A	Aim & Tools Required	10
B	Procedure / Observation	20
C	Report / Troubleshooting	20
D	Output / Result	10
E	Written Test (Theory Portions only)	30
F	Viva Voce	10
TOTAL		100

**Note:** For the written test 30 MCQ shall be asked from the theory portions.



1021236241	<b>VEHICLE TESTING</b>	L	T	P	C
PRACTICUM		1	0	4	3

### Syllabus Contents

<b>Unit I</b>	<b>VEHICLE MAINTENANCE</b>			
Importance of vehicle maintenance – scheduled and unscheduled maintenance – safety rules for automotive maintenance – vehicle safety equipment - Bearing material - Bearing definition and its types - Maintenance of bearings.				3
<b>Practical:</b> <b>Exercise 1:</b> Study on layout of automobile service stations. <b>Exercise 2:</b> Tighten and adjust the wheel bearing.				10
<b>Unit II</b>	<b>CLUTCH AND BRAKE MAINTENANCE</b>			
Necessity for clutch – the friction clutch - single plate and multiplate clutch arrangements - Clutch routine maintenance - Clutch release mechanism - Clutch assembly - Braking principles and its operating systems - types of brakes - Brake routine maintenance.				3
<b>Practical:</b> <b>Exercise 3:</b> Adjustment of pedal play in clutch, brake and hand brake lever. <b>Exercise 4:</b> Air bleeding from hydraulic brakes, air bleeding of diesel fuel system.				10
<b>Unit III</b>	<b>ENGINE MANAGEMENT SYSTEM</b>			
Requirements of engine management system - Vehicle emission and testing. Transmission systems – different types of Gears and gearboxes – propeller shafts and driveshafts – universal joint and its types – purpose of differential – principle of operation.				3
<b>Practical:</b> <b>Exercise 5:</b> Minor and major tune up of gasoline/diesel engines. <b>Exercise 6:</b> Drive train maintenance: propeller shaft, universal joint, differential.				10



1021236241	<b>VEHICLE TESTING</b>	L	T	P	C
PRACTICUM		1	0	4	3

<b>Unit IV</b>	<b>VEHICLE ELECTRICAL SYSTEM</b>			
	Electrical systems – basic principles of electricity - Charging circuit - Starting circuit - Ignition circuit - Fuel injection circuit - lighting circuit - auxiliary circuit and its routine maintenance.			3
	<b>Practical:</b> <b>Exercise 7:</b> Fault diagnosis and service of Electrical systems like battery, starting system, charging system, lighting system. <b>Exercise 8:</b> Automotive Headlight Beam Alignment test.			10
<b>Unit V</b>	<b>STEERING SYSTEM AND ITS MAINTENANCE</b>			
	Basic principles of a steering mechanism and its components - Steering system maintenance - Wheel alignment maintenance - Pneumatic tire - tire construction - tire profile - Inflation pressure - tire markings - tire wear - Diagnosis of tire wear.			3
	<b>Practical:</b> <b>Exercise 9:</b> Wheel alignment in Four Wheelers. <b>Exercise 10:</b> Remove and fit the tire after inflation.			10
			Practice + Test + Revision	10
			<b>TOTAL HOURS</b>	<b>75</b>

**Text book for Reference:**

1. V.A.W.Hillier & Peter coombes, "Hillier's Fundamentals of Motor vehicle technology", Oxford University Press, 2012.
2. Er.M.S.Saleem and Dr. S Khan, "Automobile Maintenance Repair and Service", Bluerose Publishers, 2022.
3. S.K.Gupta, "A Textbook of Automobile Engineering", S.CHAND publishers,2020.

**Web-based/Online Resources:**

- <https://archive.nptel.ac.in/courses/107/106/107106088/>



1021236241	<b>VEHICLE TESTING</b>	L	T	P	C
PRACTICUM		1	0	4	3

**LIST OF EQUIPMENT / TOOLS / MACHINERIES REQUIRED**

S.No.	Machinery's/Equipment/Tools	Quantity
1	Four Wheeler Vehicle (in Working Condition)	01
2	Hydraulic Brake system	01
3	Petrol or Diesel Engine system	01
4	Drivetrain system	01
5	Vehicle Electrical system	01
6	Vehicle Headlight System	01
7	Wheel Aligner	01
8	Tires	01
9	Vehicle bearings	Sufficient Quantity
10	Service manuals	Sufficient Quantity
11	Automobile shop floor tools	Sufficient Quantity
12	Tool Box	Sufficient Quantity

**END SEMESTER EXAMINATIONS – PRACTICAL EXAM**

**Note:** All the exercises / experiments should be completed before the Board Practical Examinations. End Semester Practical examination should be conducted for all the exercises / experiments for 100 Marks. Students will be permitted to select any one exercise by lot or question paper supplied by the DOTE Exam section shall be used.

The Practical Documents by the student should be submitted with a Bonafide Certificate.

PART	DESCRIPTION	MARKS
A	Aim & Tools Required	10
B	Procedure / Observation	20
C	Report / Troubleshooting	20
D	Output / Result	10
E	Written Test (Theory Portions only)	30
F	Viva Voce	10
TOTAL		100

**Note:** For the written test 30 MCQ shall be asked from the theory portions.



1021236242	<b>EARTH MOVING EQUIPMENTS</b>	L	T	P	C
PRACTICUM		1	0	4	3

### **Introduction**

Earthmoving equipment is a heavy duty vehicle outlined to perform constructional and mining operations which requires earthworks. The Asia-Pacific has the huge global market share of about two fifth of the global market for earthmoving equipment, which is followed by North America and Europe. Raising urban population demands for better facilities are proving greater opportunity for construction and mining industry, which in turn increases the demand for heavy machines like earthmovers, especially in developing countries such as India and China. In this course the student will be exposed to build, troubleshoot and maintain the hydraulic systems of the earthmovers, Selection of right type of earthmovers based on the requirement, service and maintenance of different earth moving equipment and also to troubleshoot hydraulic components of the earthmovers.

### **Course Objectives**

The objective of this course is to enable the student

- Select the right equipment by analyzing different criteria, perform cost Estimation and analysis of the earthmovers based on given criteria.
- Build the hydraulic manually and through any open-source simulation software.
- Troubleshoot and service the hydraulic system of earthmovers.
- Troubleshooting / servicing of different Earth moving, Material handling and other construction equipment.

### **Course Outcomes**

On successful completion of this course, the student will be able to

CO 1: Understand the various types of equipment to be used in the construction projects and different Earth Moving Operations.

CO 2: Learn the purpose, applications, types, construction and working of different Hydraulic components like actuators, Valves, Pumps.

CO 3: Demonstrate the hydraulic circuits.

CO 4: Decide the specification, attachments, working of the power shovel.

Co 5: Decide the specification, attachments, working of the excavator and the Bull Dozer.



1021236242	<b>EARTH MOVING EQUIPMENTS</b>	L	T	P	C
PRACTICUM		1	0	4	3

**Pre-requisites**

NIL

**CO/PO Mapping**

CO / PO	P01	P02	P03	P04	P05	P06	P07
<b>C01</b>	2	1	1	1	-	1	-
<b>C02</b>	2	2	1	1	-	1	-
<b>C03</b>	2	2	1	1	-	1	-
<b>C04</b>	2	2	1	1	-	1	-
<b>C05</b>	2	1	1	1	-	1	-

Legend: 3-High Correlation, 2-Medium Correlation, 1-Low Correlation

**Instructional Strategy:**

- Engage and Motivate: Instructors should actively engage students to boost their confidence.
- Real-World Relevance: Incorporate relatable, real-life examples and engineering applications to help students understand and appreciate course concepts.
- Interactive Learning: Utilize demonstrations and plan interactive student activities for an engaging learning experience.
- Application-Based Learning: Employ a theory-demonstrate-practice-activity strategy throughout the course to ensure outcome-driven learning and employability.



1021236242	<b>EARTH MOVING EQUIPMENTS</b>	L	T	P	C
PRACTICUM		1	0	4	3

**Assessment Methodology:**

	Continuous Assessment (40 marks)				End Semester Examination (60 marks)
	CA1	CA2	CA3	CA4	
<b>Mode</b>	Practical Test	Practical Test	Written Test Theory	Practical Test	Practical Examination
<b>Portion</b>	Cycle I Exercises	Cycle II Exercises	All Units	All Exercises	All Exercises
<b>Duration</b>	2 Periods	2 Periods	3 Hours	3 Hours	3 hours
<b>Exam Marks</b>	60	60	100	100	100
<b>Converted to Marks</b>	10	10	15	15	60
<b>Marks</b>	10		15	15	60
<b>Tentative Schedule</b>	7th Week	14th Week	15th Week	16th Week	

Note:

- **CA1 and CA2:** All the exercises/experiments should be completed as per the portions above and kept for the practical test. The students shall be permitted to select any one by lot for the test. The practical test should be conducted as per the scheme of evaluation as below. The marks awarded shall be converted to 10 Marks for each assessment test. Best of one will be considered for the internal assessment of 10 Marks.

Practical documents should be maintained for every exercise / experiment immediately after completion of the practice. The practical document should be submitted for the practical test. The same should be evaluated for 10 Marks for each exercise/experiment.



1021236242	<b>EARTH MOVING EQUIPMENTS</b>	L	T	P	C
PRACTICUM		1	0	4	3

The total marks awarded should be converted to 10 Marks for the practical test as per the scheme of evaluation as below.

**The details of the practical documents are to be prepared as per the instructions below.**

Each exercise / Experiment procedure, observation and calculations should be completed on the day of practice. The same shall be evaluated for 10 marks on the day or the next day of practice before the commencement of the next exercise.

This documentation can be carried out in a separate notebook or a printed manual or a file with documents. The Observation, reading, calculations, report, graphs and results should be written by the student manually in the practical documents.

The evaluated practical document should be submitted for the Practical Test. The marks scored by the students should be converted to 10 marks. The same should be included as per the allocation in the practical test.

The detailed dates of the practices and its evaluations should be maintained in the course logbook. The log book and the practical documents should be submitted for the verification by the Flying Squad and DOTE Official.

#### SCHEME OF EVALUATION

PART	DESCRIPTION	MARKS
A	Aim & Tools Required	10
B	Procedure / Observation	20
C	Report / Troubleshooting	20
TOTAL		50
D	Practical Documents (As per the portions)	10
		60

**Cycle I:** 1, 2, 3, 4 and 5

**Cycle II:** 6, 7, 8, 9 and 10.



1021236242	<b>EARTH MOVING EQUIPMENTS</b>	L	T	P	C
PRACTICUM		1	0	4	3

- **CA 3:** Written Test for complete theory portions should be conducted for 100 Marks as per the question pattern below. The marks scored will be converted to 15 Marks for internal assessment.

**Question pattern – Written Test Theory**

Description		Marks	
Part – A	30 MCQ from the complete theory portions	30 X 1 Mark	30 Marks
Part – B	Seven Questions to be answered out of 10 Questions.	7 X 10 Marks	70 Marks
TOTAL			100 Marks

- **CA 4:** All the exercises/experiments should be completed and kept for the practical test. The students shall be permitted to select any one by lot for the test. The practical test should be conducted as per the scheme of evaluation below. After completion of all the exercises, the practical test should be conducted as per the End Semester Examination question pattern scheme of evaluation. The marks awarded should be converted to 15 Marks for the internal assessment.

**SCHEME OF EVALUATION**

**Model Practical Examination and End Semester Examination - Practical Exam**

PART	DESCRIPTION	MARKS
A	Aim & Tools Required	10
B	Procedure / Observation	20
C	Report / Troubleshooting	20
D	Output / Result	10
E	Written Test (Theory Portions only)	30
F	Viva Voce	10
TOTAL		100

**Note:** For the written test 30 MCQ shall be asked from the theory portions.



1021236242	<b>EARTH MOVING EQUIPMENTS</b>	L	T	P	C
PRACTICUM		1	0	4	3

### Syllabus Contents

<b>Theory Portions</b>	
<p>Fundamentals of Earth Work Operations:</p> <p>Earth Moving Operations- Application - Difference between Construction and Mining process/operation. Types of Earth Work Equipment. Mining Equipment – Types, application, load carrying capacity – excavators, power shovels, bulldozers and mining trucks.</p> <p>Hydraulic pumps: Basic components of hydraulic systems like pumps - Types of pumps - Rotary Pumps, Reciprocating Pumps, Positive displacement flow pump. - Illustration of Pascal’s Law (P).</p> <p>Hydraulic Valves: Function of Control Valves, Classification of Control valves. - Application (and working) of directional control valves - Sliding spool type, Rotary spool type, 2/2, 3/2, 4/2, 5/2, 5/3, Poppet valve. - Hydraulic accumulator.</p> <p>Application and working of Pressure control valves - Pressure relief valve - Pressure reducing valve.</p> <p>Actuators: Application and working of different types of hydraulic components like actuators: cylinder type-ram type and piston type- single acting cylinder, double acting cylinder. - Rotary actuators - Gear - vane - piston - Unidirectional – Bidirectional actuators.</p> <p>Power shovel: Operation of Power shovel - Levelling and Pushing operations - Traveling on Sloping Ground.</p> <p>Excavators: Types- Specifications - Working principle - Parts &amp; attachments (outline drawing), working of each part and attachment.</p> <p>Bull-Dozer: Dozer parts and functions - Types - Working/Operation of each type - Specification. - Bulldozer blades - types - Explanation. - Rippers - types - Explanation.</p>	15



1021236242	<b>EARTH MOVING EQUIPMENTS</b>	L	T	P	C
PRACTICUM		1	0	4	3

<p><b>Practical:</b></p> <p><b>Exercise 1:</b> Draw the circuit diagram of the hydraulic system used in different types of earthmovers.</p> <p><b>Exercise 2:</b> Study and draw the symbols of various Hydraulics &amp; Pneumatic elements.</p> <p><b>Exercise 3:</b> Determine the Coefficient of discharge of Venturi meter.</p> <p><b>Exercise 4:</b> Draw and execute the hydraulic circuit to control a single acting hydraulic cylinder.</p> <p><b>Exercise 5:</b> Draw and execute the hydraulic circuit to control a double acting hydraulic cylinder.</p> <p><b>Exercise 6:</b> Demonstrate the working of flow control valves - Non return valve - pilot operated sequence valve, Sequence valve.</p> <p><b>Exercise 7:</b> Maintenance of hydraulic system: Its common faults - visual checks of oil - causes of contamination- preventive measures – maintenance schedule.</p> <p><b>Exercise 8:</b> Pre-operational checks and maintenance of power shovel.</p> <ol style="list-style-type: none"> <li>a. Tyres and wheels- Practice on wheel changing.</li> <li>b. Checking Lubrication and hydraulic system.</li> <li>c. Checking Oil levels – engine sump, transmission and differential case.</li> </ol> <p><b>Exercise 9:</b> Perform Pre- operational Inspection of excavator.</p> <p><b>Exercise 10:</b> Demonstrate the Operating procedure of excavator.</p>	50
Revision + Test	10
Total	75

### Students activity

Visit and practice in the various types of earth moving equipment.

Safety procedures and demonstration activity can be performed.

Visit the logistics centre to study about the material handling equipment.

Prepare a chart for the maintenance and troubleshooting of the hydraulic components in the system.



1021236242	<b>EARTH MOVING EQUIPMENTS</b>	L	T	P	C
PRACTICUM		1	0	4	3

**Text book for Reference:**

1. Deodhar, S.V. "Construction Equipment and Job Planning" , Khanna Publishers, New Delhi.
2. Power Shovels: The World's Mightiest Mining and Construction Excavators by Eric C Orlemann, MBI Publisher (August 12, 2003).
3. Oil Hydraulic System By S R Majumdar.
4. "Construction Machines: Excavators" by Murray Julie, North Star Editions
5. Fluid power transmission and control system by P.G. Mundas

**Web-based/Online Resources:**

<https://www.youtube.com/watch?v=Ev1wa0wRpqk>

<https://www.youtube.com/watch?v=YrYdZ6J8Qxl>

<https://www.youtube.com/watch?v=tldOKQiMvAk>

[https://www.youtube.com/watch?v=\\_iZbFTa\\_4Sc](https://www.youtube.com/watch?v=_iZbFTa_4Sc)

<https://www.youtube.com/watch?v=gKUrPUB0eXQ>

Yanmar Academy Excavator Lifting Hook Installation - YouTube

YANMAR Academy Excavator Thumb Installation (youtube.com)



1021236242	<b>EARTH MOVING EQUIPMENTS</b>	L	T	P	C
PRACTICUM		1	0	4	3

**LIST OF EQUIPMENT / TOOLS / MACHINERIES REQUIRED**

S.No.	Machinery's/Equipment/Tools	Quantity
1	Venturimeter test rig.	1 No.
2	Non return valve - pilot operated sequence valve, Sequence valve.	1 Each
3	Power shovel	1 No.
4	Excavator	1 No.
5	Hydraulic cylinder and Components	Sufficient quantity.
6	Service Manuals	As per requirement
7	Charts	As per requirement



1021236242	<b>EARTH MOVING EQUIPMENTS</b>	L	T	P	C
PRACTICUM		1	0	4	3

### END SEMESTER EXAMINATIONS – PRACTICAL EXAM

**Note:**

All the exercises / experiments should be completed before the Board Practical Examinations. End Semester Practical examination should be conducted for all the exercises / experiments for 100 Marks. Students will be permitted to select any one exercise by lot or question paper supplied by the DOTE Exam section shall be used.

The Practical Documents by the student should be submitted with a Bonafide Certificate.

PART	DESCRIPTION	MARKS
A	Aim & Tools Required	10
B	Procedure / Observation	20
C	Report / Troubleshooting	20
D	Output / Result	10
E	Written Test (Theory Portions only)	30
F	Viva Voce	10
TOTAL		100

**Note:** For the written test 30 MCQ shall be asked from the theory portions.



1020236243	<b>NON DESTRUCTIVE TESTING</b>	L	T	P	C
PRACTICUM		1	0	4	3

**Introduction:**

Non-destructive testing (NDT) is a multidisciplinary profession that blends quality assurance and materials science. NDT is used to inspect and evaluate materials, components, or assemblies without destroying their serviceability. Through a set of test methods, skilled technicians identify cracks, voids, inclusions, and weld discontinuities, as well as identify misassembled subcomponents. This makes NDT crucial to help prevent catastrophic failures such as airplane and locomotive crashes, pipeline leaks and explosions, nuclear reactor failures, and ship disasters.

**Course Objectives:**

The objective of this course is to prepare the student,

- To learn about the various Non Destructive testing methods.
- To identify the types of equipment used for each Non-Destructive and Destructive Examination.
- To study about the process of Surface Testing Methods(LPT & MPT)
- To learn about the Sub Surface Testing methods(RT & UT)
- To study about the various applications of NDT Tests in Industries.

**Course Outcomes**

**C01:** Explain NDT techniques which enable it to carry out various inspections in accordance with the established procedures.

**C02:** Calibrate the instrument and inspect for in-service damage in the components.

**C03:** Differentiate various defect types and select the appropriate NDT methods for better evaluation.

**C04:** Communicate their conclusions clearly to specialist and non-specialist audiences.

**C05:** Prepare the testing and evaluation of the results for further analysis.

**Pre-requisites:**

Knowledge of basic measuring instruments, material processing, and various types of materials defects.



1020236243	<b>NON DESTRUCTIVE TESTING</b>	L	T	P	C
PRACTICUM		1	0	4	3

### CO/PO Mapping

CO / PO	P01	P02	P03	P04	P05	P06	P07
<b>C01</b>	3	-	-	3	-	-	-
<b>C02</b>	3	-	-	3	-	-	-
<b>C03</b>	3	-	-	3	-	-	-
<b>C04</b>	3	-	-	3	-	-	-
<b>C05</b>	3	-	-	3	-	-	-

Legend: 3-High Correlation, 2-Medium Correlation, 1-Low Correlation

### Instructional Strategy:

- It is advised that teachers take steps to pique pupils' attention and boost their curiosity to learn.
- Implement task-based learning activities where students work on specific tasks or projects.
- Incorporate technology tools and resources, such as online platforms, interactive multimedia, and virtual communication tools, to enhance engagement and provide additional practice opportunities.
- Incorporate formative and summative assessments to gauge student progress and provide targeted feedback.
- Throughout the course, a theory-demonstrate-practice-activity strategy may be used to ensure that learning is outcome and employability based.
- All demonstrations/Hand-on practices may be followed in the real environment as far as possible.



1020236243	<b>NON DESTRUCTIVE TESTING</b>	L	T	P	C
PRACTICUM		1	0	4	3

**Assessment Methodology:**

	Continuous Assessment (40 marks)				End Semester Examination (60 marks)
	CA1	CA2	CA3	CA4	
<b>Mode</b>	Practical Test	Practical Test	Written Test Theory	Practical Test	Practical Examination
<b>Portion</b>	Cycle I Exercises	Cycle II Exercises	All Portions	All Exercises	All Exercises Experiments
<b>Duration</b>	2 Periods	2 Periods	3 Hours	3 Hours	3 hours
<b>Exam Marks</b>	60	60	100	100	100
<b>Converted to Marks</b>	10	10	15	15	60
<b>Marks</b>	10		15	15	60
<b>Tentative Schedule</b>	7th Week	14th Week	15th Week	16th Week	

Note:

**CA1 and CA2:** All the exercises/experiments should be completed as per the portions above and kept for the practical test. The students shall be permitted to select any one by lot for the test. The practical test should be conducted as per the scheme of evaluation as below. The marks awarded shall be converted to 10 Marks for each assessment test. Best of one will be considered for the internal assessment of 10 Marks.

Practical documents should be maintained for every experiment immediately after completion of the practice. The practical document should be submitted for the practical test. The same should be evaluated for 10 Marks for each exercise/experiment. The total marks awarded should be converted to 10 Marks for the practical test as per the scheme of evaluation as below.



1020236243	<b>NON DESTRUCTIVE TESTING</b>	L	T	P	C
PRACTICUM		1	0	4	3

**The details of the documents to be prepared as per the instruction below.**

Each exercise should be completed on the day of practice. The same shall be evaluated for 10 marks on the day or next day of practice before commencement of the next experiment.

This documentation can be carried out in a separate notebook or a printed manual or a file with documents. The Procedure, Sketch and Result / Output should be written by the student manually in the documents.

The detailed date of the practices and its evaluations should be maintained in the course logbook. The log book and the practical documents should be submitted for the verification by the Flying Squad and DoTE Official.

#### SCHEME OF EVALUATION

PART	DESCRIPTION	MARKS
A	Procedure / Preparation	15
B	Observation / Sketch	20
C	Accuracy	15
TOTAL		50
D	Practical Documents (As per the portions)	10
		60

Cycle - I - Exercise 1, 2, 3 and 4.

Cycle - II - Exercise 5, 6, 7 and 8..

**CA 3:** Written Test for complete theory portions should be conducted for 100 Marks as per the question pattern below. The marks scored will be converted to 15 Marks for internal assessment.



1020236243	<b>NON DESTRUCTIVE TESTING</b>	L	T	P	C
PRACTICUM		1	0	4	3

**Question pattern – Written Test Theory**

Description		Marks	
Part – A	30 MCQ Questions.	30 X 1 Mark	30 Marks
Part – B	7 Questions to be answered out of 10 Questions.	7 X 10 Marks	70 Marks
TOTAL			100 Marks

**CA 4:** All the exercises/experiments should be completed and kept for the practical test. The students shall be permitted to select any one by lot for the test. The practical test should be conducted as per the scheme of evaluation below. After completion of all the exercises the practical test should be conducted as per End Semester Examination question pattern scheme of evaluation. The marks awarded should be converted to 15 Marks for the internal assessment.

**SCHEME OF EVALUATION**

**Model Practical Examination and End Semester Examination - Practical Exam**

PART	DESCRIPTION	MARKS
A	Procedure/Preparation	15
B	Observation/Drawing	20
C	Accuracy	15
D	Result	10
E	Written Test	30
F	Viva Voce	10
TOTAL		100

Note: For the written test 30 MCQ shall be asked from the theory portions.



1020236243	<b>NON DESTRUCTIVE TESTING</b>	L	T	P	C
PRACTICUM		1	0	4	3

### Syllabus Contents

<b>Theory Portion - Unit I</b>	
<p><b>Introduction:</b> Non destructive testing (NDT) and its comparison with destructive testing, Defects/ flaws due to primary processing, secondary processing and inservice, Types of defects determined by NDT, Common non-destructive testing techniques, Advantages, limitations and applications of NDT.</p> <p><b>Visual Inspection:</b> Principle of visual Inspection, Defects which can be detected by unaided visual Inspection, Optical aids used for visual inspection, Advantages and limitations of visual inspection.</p> <p><b>Liquid Penetrant Test:</b> Advantages and limitations of Liquid Penetrant Test (LPT), Physical principles of LPT, Procedure employed for LPT, Penetrant methods, Materials used in LPT.</p> <p><b>Magnetic Particle Test:</b> Advantages and limitations of Magnetic Particle Test (MPT), Procedure of MPT, Magnetizing Magnetic particles and suspending liquids, Detectable discontinuities, Non-relevant indications, Applications.</p>	8
<b>Practical Exercises</b>	
<b>Exercise 1:</b> Detect the cracks in the specimen using Visual Inspection and ring test.	6
<b>Exercise 2:</b> Detect the Small surface flaws in the specimen using Microscopy Examination test.	6
<b>Exercise 3:</b> Detect the Subsurface flaws in the specimen using Radiography.	6
<b>Exercise 4:</b> Detecting Surface flaws in specimen using Die-penetration test.	6
<b>Theory Portion - Unit II</b>	
<p><b>Eddy Current Test:</b> Advantages and limitations of Eddy Current Test (ECT), Operation variables, Eddy current instrumentation, Reference standards, Applications.</p> <p><b>Ultrasonic Test:</b> Advantages and limitations of Ultrasonic Test (UT), General characteristics of ultrasonic waves, Wave propagation and types of ultrasonic</p>	7



1020236243	<b>NON DESTRUCTIVE TESTING</b>	L	T	P	C
PRACTICUM		1	0	4	3

<p>waves, Major variables in UT, Angle beam techniques, Immersion testing, Applications.</p> <p><b>Radiography Test:</b> Uses/ Applicability of radiography, Advantages and limitations of Radiography Test (RT), Interaction between penetrating radiation &amp; matter (Attenuation), Image conversion media, Film radiography, Real time radiography.</p> <p><b>Other Non-destructive Inspection Techniques:</b> Acoustic emission inspection, Microwave inspection, Thermal inspection, Electromagnetic techniques for residual stress measurements, Optical holography, etc.</p>	
<b>Practical Exercises</b>	
<b>Exercise 5:</b> Detect of Surface flaws in specimen using Ultrasonic test.	6
<b>Exercise 6:</b> Detect the cracks in specimen using Magnetic particle test.	6
<b>Exercise 7:</b> Detect the Surface and near surface flaws in specimen using Eddy Current test.	6
<b>Exercise 8:</b> Case Study experiment - Can analyze entire structure of Any one used machine components using Acoustic emission test.	6
Assessment Test + Revision	12
Total	75

### TEXT BOOKS

1. "Non Destructive Evaluation and Quality Control", Metals Handbook, Vol. 17, 9th Ed., ASM.1989
2. Srivastava, K.C., "Handbook of Magnetic Particle Testing", Oscar publications. 1998
3. Hull, B., "Non Destructive Testing", Springer. 2012
4. Dr.V.Jayakumar,Dr.K.Elangovan"Non-Destructive Testing of Materials"Lakshmi Publications,Chennai,2017
5. Baldev Raj, Jayakumar T, Thavasimuthu M, Practical Non- Destructive Testing, 3rd Ed., Narosa. 2019



1020236243	<b>NON DESTRUCTIVE TESTING</b>	L	T	P	C
PRACTICUM		1	0	4	3

**Web-based/Online Resources:**

- [www.ndt-ed.org](http://www.ndt-ed.org)
- [www.krautkramer.com.au](http://www.krautkramer.com.au)
- [https://onlinecourses.nptel.ac.in/noc23\\_mm05](https://onlinecourses.nptel.ac.in/noc23_mm05)

**END SEMESTER EXAMINATION - Practical Exam**

**Note:**

All the exercises should be completed before the Board Practical Examinations. End Semester Practical examination should be conducted for all the exercises / experiments for 100 Marks. Students will be permitted to select any one exercise by lot or question paper supplied by the DOTE Exam section shall be used. The practical document prepared by the student should be submitted with a Bonafide Certificate.

**SCHEME OF EVALUATION**

PART	DESCRIPTION	MARKS
A	Procedure/Preparation	15
B	Observation/Drawing	20
C	Accuracy	15
D	Result	10
E	Written Test	30
F	Viva Voce	10
TOTAL		100

Note: For the written test 30 MCQ shall be asked from the theory portions.



1020236244	<b>Process Automation</b>	L	T	P	C
PRACTICUM		1	0	4	3

**Introduction:**

Process automation uses technology to automate complex business processes. It typically has three functions: automating processes, centralizing information, and reducing the requirement for input from people. It is designed to remove bottlenecks, reduce errors and loss of data, all while increasing transparency, communication across departments, and speed of processing. Process automation uses technology to automate complex business processes. It typically has three functions: automating processes, centralizing information, and reducing the requirement for input from people. It is designed to remove bottlenecks, reduce errors and loss of data, all while increasing transparency, communication across departments, and speed of processing.

**Course Objectives:**

The objective of this course is to enable the student to

- Design and operate pneumatic circuits.
- Design and operate fluid power circuits.
- Use PLC system and its elements for process control.
- Familiarize the working of function blocks in PLC
- Use ON-Delay timer to control a motor
- Use OFF-Delay timer to control a motor
- Use counter function block (Up counter and Down counter)
- Control the automatic operation of pneumatic cylinder using PLC

**Course Outcomes**

On successful completion of this course, the student will be able to

CO1: Explain the working of hydraulic and pneumatics systems and its elements.

CO2: Familiarise the various symbols of hydraulic and pneumatics systems

CO3: Construct the Hydraulic and Pneumatics circuits for different applications

CO4: Explain the working of logic gates and features of PLC

CO5: Apply the Logic gates and PLC for the automatic operations of hydraulics and pneumatic machines.



1020236244	<b>Process Automation</b>	L	T	P	C
PRACTICUM		1	0	4	3

**Pre-requisites:**

Fluid Mechanics, Basic Electrical and Mechanical Engineering

**CO/PO Mapping**

CO / PO	P01	P02	P03	P04	P05	P06	P07
<b>C01</b>	3	-	-	3			
<b>C02</b>	3	-	-	3			
<b>C03</b>	3	-	-	3			
<b>C04</b>	3	-	-	3			
<b>C05</b>	3	-	-	3			

Legend: 3-High Correlation, 2-Medium Correlation, 1-Low Correlation

**Instructional Strategy:**

- It is advised that teachers take steps to pique pupils' attention and boost their curiosity to learn. Implement task-based learning activities where students work on specific tasks or projects.
- Incorporate technology tools and resources, such as online platforms, interactive multimedia, and virtual communication tools, to enhance engagement and provide additional practice opportunities.
- Incorporate formative and summative assessments to gauge student progress and provide targeted feedback.
- Throughout the course, a theory-demonstrate-practice-activity strategy may be used to ensure that learning is outcome and employability based.
- All demonstrations/Hand-on practices may be followed in the real environment as far as possible.



1020236244	<b>Process Automation</b>	L	T	P	C
PRACTICUM		1	0	4	3

**Assessment Methodology:**

	Continuous Assessment (40 marks)				End Semester Examination (60 marks)
	CA1	CA2	CA3	CA4	
<b>Mode</b>	Practical Test	Practical Test	Written Test Theory	Practical Test	Practical Examination
<b>Portion</b>	Cycle I Exercises	Cycle II Exercises	All Portions	All Exercises	All Exercises Experiments
<b>Duration</b>	2 Periods	2 Periods	3 Hours	3 Hours	3 hours
<b>Exam Marks</b>	60	60	100	100	100
<b>Converted to Marks</b>	10	10	15	15	60
<b>Marks</b>	10		15	15	60
<b>Internal Marks</b>	40				
<b>Tentative Schedule</b>	7th Week	14th Week	15th Week	16th Week	

Note:

**CA1 and CA2:** All the exercises/experiments should be completed as per the portions above and kept for the practical test. The students shall be permitted to select any one by lot for the test. The practical test should be conducted as per the scheme of evaluation as below. The marks awarded shall be converted to 10 Marks for each assessment test. Best of one will be considered for the internal assessment of 10 Marks.

Practical documents should be maintained for every experiment immediately after completion of the practice. The practical document should be submitted for the practical test. The same should be evaluated for 10 Marks for each exercise/experiment. The total marks awarded should be converted to 10 Marks for the practical test as per the scheme of evaluation as below.



1020236244	<b>Process Automation</b>	L	T	P	C
PRACTICUM		1	0	4	3

**The details of the documents to be prepared as per the instruction below.**

Each exercise should be completed on the day of practice. The same shall be evaluated for 10 marks on the day or next day of practice before commencement of the next experiment.

This documentation can be carried out in a separate notebook or a printed manual or a file with documents. The Procedure, Sketch and Result / Output should be written by the student manually in the documents.

The detailed date of the practices and its evaluations should be maintained in the course logbook. The log book and the practical documents should be submitted for the verification by the Flying Squad and DoTE Official.

#### SCHEME OF EVALUATION

PART	DESCRIPTION	MARKS
<b>A</b>	Procedure / Preparation	15
<b>B</b>	Circuit / Program	20
<b>C</b>	Execution / Connection	15
TOTAL		50
<b>D</b>	Practical Documents (As per the portions)	10
		60

Cycle - I - Exercise 1, 2, 3,4 and 5.

Cycle - II - Exercise 6, 7, 8, 9 and 10.

**CA 3:** Written Test for complete theory portions should be conducted for 100 Marks as per the question pattern below. The marks scored will be converted to 15 Marks for internal assessment.



1020236244	<b>Process Automation</b>	L	T	P	C
PRACTICUM		1	0	4	3

**Question pattern – Written Test Theory**

Description		Marks	
Part – A	30 MCQ Questions.	30 X 1 Mark	30 Marks
Part – B	7 Questions to be answered out of 10 Questions.	7 X 10 Marks	70 Marks
TOTAL			100 Marks

**CA 4:** All the exercises/experiments should be completed and kept for the practical test. The students shall be permitted to select any one by lot for the test. The practical test should be conducted as per the scheme of evaluation below. After completion of all the exercises the practical test should be conducted as per End Semester Examination question pattern scheme of evaluation. The marks awarded should be converted to 15 Marks for the internal assessment.

**SCHEME OF EVALUATION**

**Model Practical Examination and End Semester Examination - Practical Exam**

PART	DESCRIPTION	MARKS
A	Procedure / Preparation	15
B	Circuit / Program	20
C	Execution / Connection	15
D	Result	10
E	Written Test	30
F	Viva Voce	10
TOTAL		100

Note: For the written test 30 MCQ shall be asked from the theory portions.

**Syllabus Contents**



1020236244	<b>Process Automation</b>	L	T	P	C
PRACTICUM		1	0	4	3

<b>Theory Portion</b>	
<b>UNIT I: HYDRAULICS AND PNEUMATIC SYSTEMS</b>	7
<p>Pneumatic systems: Elements-FLR unit-Direction Control Valves-Flow control Valves-ISO Symbols of Pneumatic Components-pneumatic circuits for various industrial applications.</p> <p>Hydraulic Systems: Elements – comparison of Pneumatic systems and Hydraulic systems-service properties of hydraulic fluids-ISO symbols of hydraulic Components-hydraulic circuits for various industrial applications.</p>	
<b>Practical Exercises</b>	
<b>Pneumatics Lab</b>	15
<b>Exercise 1:</b> Operation of double acting cylinder with quick exhaust valve.	
<b>Exercise 2:</b> Speed control of a double acting cylinder using metering-in and metering-out circuits.	
<b>Exercise 3:</b> Automatic operation of double acting cylinder in single cycle - using limit switch.	
<b>Hydraulics Lab</b>	10
<b>Exercise 4:</b> Direct operation of the double acting cylinder.	
<b>Exercise 5:</b> Speed control of double acting cylinder metering-in and metering-out control.	

<b>Theory Portion</b>	
<b>UNIT II: LOGIC GATES AND PLC</b>	8
<p><b>PLC</b></p> <p>Features of PLC - PLC Block diagram - PLC scan. Fixed and Modular PLC. Ladder logic - Basic principles of Ladder diagram , Analog I / O and Digital I /O, NO, NC contacts - Coils - AND logic, OR logic.- Applications - Timer - Counter.</p>	
<b>Practical Exercises</b>	
<b>PLC Lab</b>	25
<b>Exercise 6:</b> Direct operation of a motor using a latching circuit, AND, OR, logic circuits.	
<b>Exercise 7:</b> On-Delay control of a motor and Off –Delay control of a motor.	



1020236244	<b>Process Automation</b>	L	T	P	C
PRACTICUM		1	0	4	3

<b>Exercise 8:</b> Automatic operation of Double acting cylinder-Multi cycle.	
<b>Exercise 9:</b> Sequential operation of a double acting cylinder and a motor.	
<b>Exercise 10:</b> Automatic operation of DAC, Forward time delay return.	
Assessment Test and Revision	10
Total	75

### **END SEMESTER EXAMINATION - Practical Exam**

**Note:**

All the exercises should be completed before the Board Practical Examinations. End Semester Practical examination should be conducted for all the exercises / experiments for 100 Marks. Students will be permitted to select any one exercise by lot or question paper supplied by the DOTE Exam section shall be used. The practical document prepared by the student should be submitted with a Bonafide Certificate.

### **SCHEME OF EVALUATION**

<b>PART</b>	<b>DESCRIPTION</b>	<b>MARKS</b>
<b>A</b>	Procedure / Preparation	15
<b>B</b>	Circuit / Program	20
<b>C</b>	Execution / Connection	15
<b>D</b>	Result	10
<b>E</b>	Written Test	30
<b>F</b>	Viva Voce	10
<b>TOTAL</b>		<b>100</b>

Note: For the written test 30 MCQ shall be asked from the theory portions.



1020236244	<b>Process Automation</b>	L	T	P	C
PRACTICUM		1	0	4	3

**Equipment / Facilities required to conduct the Practical Course.**

**Note: The components should be supplied separately. Students should fix the board to execute the circuit.**

1. Pneumatic Trainer Board – 2 Nos  
(All Cylinders, Control Valves, Limit switches and other accessories should be kept separately and should not be fixed permanently in the board/ stand.)
2. Hydraulics Trainer Board – 2 No.  
(All Cylinders, Control Valves, Limit switches and other accessories should be kept separately and should not be fixed permanently in the board / stand.)
3. PLC – 3 Nos.
4. Computer with software – 10 Nos.



1021236245	<b>ADDITIVE MANUFACTURING</b>	L	T	P	C
PRACTICUM		1	0	4	3

**Introduction:**

The purpose of this course is to teach the fundamentals of additive manufacturing (AM) of rapidly evolving and widely used technology. To create awareness of the technology for conceptual modeling, prototyping and rapid manufacturing. This is a major technical course. It provides knowledge of wide applications of additive manufacturing (AM) in industry and society.

**Course Objectives:**

- ❖ To study about the designing of 3D drawing in CAD
- ❖ To gain knowledge and skills related to 3D printing technologies.
- ❖ To learn about the selection of material, equipment and development of a product for Industry 4.0 environment.
- ❖ To understand the various software tools, processes and techniques for digital manufacturing.
- ❖ To apply these techniques into various applications

**Course Outcomes:**

On successful completion of this course, the student will be able to

- C01: Develop CAD models for 3D printing
- C02: Import and Export CAD data and generate .stl file
- C03: Select a specific material for the given application
- C04: Select a 3D printing process for an application.
- C05: Produce a product using 3D Printing

**Pre-requisites:**

Computer Aided Design & Drafting, Engineering Materials



1021236245	<b>ADDITIVE MANUFACTURING</b>	L	T	P	C
PRACTICUM		1	0	4	3

### CO/PO Mapping

CO / PO	P01	P02	P03	P04	P05	P06	P07
<b>C01</b>	2	1	2	1	1	1	1
<b>C02</b>	2	1	2	1	1	1	1
<b>C03</b>	2	1	2	1	1	1	1
<b>C04</b>	2	1	2	1	1	1	1
<b>C05</b>	3	1	2	1	1	1	1

Legend: 3-High Correlation, 2-Medium Correlation, 1-Low Correlation

### Instructional Strategy:

- ❖ It is advised that teachers take necessary steps to pique pupils' attention and improve their curiosity to learn.
- ❖ Throughout the course, a theory-demonstrate-practice-activity strategy may be used to ensure that outcome based learning and employability based.



1021236245	<b>ADDITIVE MANUFACTURING</b>	L	T	P	C
PRACTICUM		1	0	4	3

**Assessment Methodology:**

	Continuous Assessment (40 marks)				End Semester Examination (60 marks)
	CA1	CA2	CA3	CA4	
<b>Mode</b>	Practical Test	Practical Test	Written Test Theory	Practical Test	Practical Examination
<b>Portion</b>	Cycle I Exercises	Cycle II Exercises	All Units	All Exercises	All Exercises
<b>Duration</b>	2 Periods	2 Periods	3 Hours	3 Hours	3 hours
<b>Exam Marks</b>	60	60	100	100	100
<b>Converted to Marks</b>	10	10	15	15	60
<b>Marks</b>	10		15	15	60
<b>Tentative Schedule</b>	7th Week	14th Week	15th Week	16th Week	

Note:

- **CA1 and CA2:** All the exercises/experiments should be completed as per the portions above and kept for the practical test. The students shall be permitted to select any one by lot for the test. The practical test should be conducted as per the scheme of evaluation as below. The marks awarded shall be converted to 10 Marks for each assessment test. Best of one will be considered for the internal assessment of 10 Marks.

Practical documents should be maintained for every exercise / experiment immediately after completion of the practice. The practical document should be submitted for the practical test. The same should be evaluated for 10 Marks for each exercise/experiment. The total marks awarded should be converted to 10 Marks for the practical test as per the scheme of evaluation as below.



1021236245	<b>ADDITIVE MANUFACTURING</b>	L	T	P	C
PRACTICUM		1	0	4	3

**The details of the practical documents are to be prepared as per the instructions below.**

Each exercise / Experiment procedure, observation and calculations should be completed on the day of practice. The same shall be evaluated for 10 marks on the day or the next day of practice before the commencement of the next exercise.

This documentation can be carried out in a separate notebook or a printed manual or a file with documents. The Observation, reading, calculations, report, graphs and results should be written by the student manually in the practical documents.

The evaluated practical document should be submitted for the Practical Test. The marks scored by the students should be converted to 10 marks. The same should be included as per the allocation in the practical test.

The detailed dates of the practices and its evaluations should be maintained in the course logbook. The log book and the practical documents should be submitted for the verification by the Flying Squad and DOTE Official.

#### SCHEME OF EVALUATION

PART	DESCRIPTION	MARKS
A	Creation - Modelling	10
B	Setting for 3D Printing and Convert to .stl file	20
C	Machine Setting	20
TOTAL		50
D	Practical Documents (As per the portions)	10
		60

**Cycle I:** 1, 2, 3, and 4.

**Cycle II:** 5, 6, 7 and 8

**CA 3:** Written Test for complete theory portions should be conducted for 100 Marks as per the question pattern below. The marks scored will be converted to 15 Marks for internal assessment.



1021236245	<b>ADDITIVE MANUFACTURING</b>	L	T	P	C
PRACTICUM		1	0	4	3

### Question pattern – Written Test Theory

Description		Marks	
Part – A	30 MCQ from the complete theory portions	30 X 1 Mark	30 Marks
Part – B	Seven Questions to be answered out of 10 Questions.	7 X 10 Marks	70 Marks
TOTAL			100 Marks

- **CA 4:** All the exercises/experiments should be completed and kept for the practical test. The students shall be permitted to select any one by lot for the test. The practical test should be conducted as per the scheme of evaluation below. After completion of all the exercises, the practical test should be conducted as per the End-Semester Examination question pattern scheme of evaluation. The marks awarded should be converted to 15 Marks for the internal assessment.

### SCHEME OF EVALUATION

#### Model Practical Examination and End Semester Examination - Practical Exam

PART	DESCRIPTION	MARKS
A	Creation - Modelling	10
B	Setting for 3D Printing and Convert to .stl file	20
C	Machine Setting	20
D	Model printing & Finishing	10
E	Written Test (Theory Portions only)	30
F	Viva Voce	10
TOTAL		100

**Note:** For the written test 30 MCQ shall be asked from the theory portions.



1021236245	<b>ADDITIVE MANUFACTURING</b>	L	T	P	C
PRACTICUM		1	0	4	3

### Syllabus Contents

<b>Theory Portion - Unit I</b>	
Additive Manufacturing Techniques. Stereo - Lithography (3D Printing), Laminated Object Manufacturing (LOM), Fused deposition modelling (FDM), Selective Laser Sintering (SLS), Selective Laser Melting (SLM), Binder Jet technology - Additive Manufacturing Application. Additive Manufacturing Application Domains: Aerospace, Electronics, Health Care, Defence, Automotive, Construction, Food Processing, Machine Tools.	8
<b>Theory Portion - Unit II</b>	
CAD for Additive Manufacturing: CAD Data formats Solid works with SWIFT technology – 2D to 3D - Data translation - Data loss - .stl format. Materials: Polymers, Metals, Non-Metals, Ceramics Process, Process parameter, Process Selection for various applications. Various forms of raw material- Liquid, Solid, Wire, Powder; Powder Preparation and their desired properties, Polymers and their properties.	7
<b>Practical Exercises</b> <b>All the exercises should be modelled and converted to .stl file. The model should be printed in a 3D Printing.</b> <b>Exercise 1:</b> Model and 3D print cube. <b>Exercise 2:</b> Model and 3D print spur gear. <b>Exercise 3:</b> Model and 3D print a double ended spanner. <b>Exercise 4:</b> Model and 3D print Four alphabet.	25
Any one project with two or three parts with assembly can be given for the group of 6 Students. The project should be selected by the respective faculty i/c. The same have to be submitted for the End Semester examination.	25
Revision + Test	10
Total	75



1021236245	<b>ADDITIVE MANUFACTURING</b>	L	T	P	C
PRACTICUM		1	0	4	3

**Suggested List of Students Activity:**

- ❖ Advised to prepare a CAD software
- ❖ Advised to practice to make a 3d drawing in different CAD software
- ❖ Advised to collect different materials.
- ❖ Advised to collect the scheduled maintenance data relevant to 3D Printer.
- ❖ Advised to collect specifications of 3D Printer

**Text book for Reference:**

1. Khanna Editorial, "3D Printing and Design", Khanna Publishing House, Delhi.
2. Lan Gibson, David W. Rosen and Brent Stucker, "Additive Manufacturing Technologies: Rapid Prototyping to Direct Digital Manufacturing", Springer, 2010.
3. Andreas Gebhardt, "Understanding Additive Manufacturing: Rapid Prototyping, Rapid Tooling, Rapid Manufacturing", Hanser Publisher, 2011.
4. CK Chua, Kah Fai Leong, "3D Printing and Rapid Prototyping- Principles and Applications", World Scientific, 2017.

**Web-based/Online Resources:**

<https://www.youtube.com/watch?v=ScZ4aw6OePw>  
<https://www.youtube.com/watch?v=5ikt5JMwr94>  
[https://www.youtube.com/watch?v=IP9EI\\_qpOI4](https://www.youtube.com/watch?v=IP9EI_qpOI4)  
<https://www.youtube.com/watch?v=e-xGJsC92Mg>  
<https://www.youtube.com/watch?v=wIkKcbEUGbA>  
<https://www.youtube.com/watch?v=PXk9VO0sUPU>  
<https://www.youtube.com/watch?v=xEFaYdnqIBQ>



1021236245	<b>ADDITIVE MANUFACTURING</b>	L	T	P	C
PRACTICUM		1	0	4	3

### END SEMESTER EXAMINATIONS – PRACTICAL EXAM

**Note:** All the exercises / experiments should be completed before the Board Practical Examinations. End Semester Practical examination should be conducted for all the exercises / experiments for 100 Marks. Students will be permitted to select any one exercise by lot or question paper supplied by the DOTE Exam section shall be used.

The Practical Documents by the student should be submitted with a Bonafide Certificate.

PART	DESCRIPTION	MARKS
A	Creation - Modelling	10
B	Setting for 3D Printing and Convert to .stl file	20
C	Machine Setting	20
D	Model printing & Finishing	10
E	Written Test (Theory Portions only)	30
F	Viva Voce	10
TOTAL		100

**Note:** For the written test 30 MCQ shall be asked from the theory portions.

#### Equipment / Facilities required.

Personal computer : 30 Nos.  
 Laser Printer : 1 No.  
 3D Printer : 1 No.  
 Printing materials : Sufficient quantity.  
 Software : GUI System Software  
 Modelling package – Sufficient to the strength.



1021236246	<b>Electrical Vehicle Technology Practical</b>	L	T	P	C
PRACTICUM		1	0	4	3

**Introduction:**

Electric vehicles (EVs) represent the forefront of automotive innovation, offering a sustainable alternative to traditional internal combustion engine vehicles. As the automotive industry rapidly shifts towards electric mobility, it is imperative for aspiring automobile engineers to gain practical, hands-on experience with EV technology.

This practical course is designed to immerse students in the fundamental aspects of electric vehicle systems, including battery technology, electric motors, power electronics, and vehicle control systems. Through a series of structured experiments, students will not only reinforce their theoretical knowledge but also develop critical technical skills required in the modern automotive landscape.

Throughout this course, students will engage in experiments such as measuring battery capacity and efficiency, designing battery management systems, controlling electric motors, and simulating vehicle dynamics. These activities are aimed at fostering a deep understanding of EV components and systems, encouraging innovation, and ensuring safety in handling high-voltage systems.

**Course Objectives:**

By the end of this practical course, students will be well-equipped with the knowledge and skills necessary to contribute to the advancement of electric vehicle technology and meet the demands of the evolving automotive industry.

**Course Outcomes:**

On successful completion of this course, the student will be able to

On successful completion of this course, the student will be able to

C01: Analyze the capacity of different types of batteries used in electric vehicles.

C02: Analyze the battery management systems and battery cooling system

C03: Apply the procedures of testing of EV motor and power converters

C04: Use a microcontroller to test EV subsystem

C05: Use a software to develop and test EV subsystem



1021236246	<b>Electrical Vehicle Technology Practical</b>	L	T	P	C
PRACTICUM		1	0	4	3

### Pre-requisites

Electric Vehicle technology & Policy

### CO/PO Mapping

CO / PO	P01	P02	P03	P04	P05	P06	P07
<b>C01</b>	1	1	1	1	-	-	1
<b>C02</b>	1	1	1	2	-	-	1
<b>C03</b>	1	1	1	2	-	-	1
<b>C04</b>	1	1	1	2	-	1	1
<b>C05</b>	1	1	1	2	-	2	1

Legend: 3-High Correlation, 2-Medium Correlation, 1-Low Correlation

### Instructional Strategy

- It is advised that teachers take steps to pique pupils' attention and boost their curiosity to learn.
- Implement task-based learning activities where students work on specific tasks or projects.
- Incorporate technology tools and resources, such as online platforms (NPTEL, , SWAYA, ect.), interactive multimedia, and virtual communication tools, to enhance engagement and provide additional practice opportunities.
- Incorporate formative and summative assessments to gauge student progress and provide targeted feedback.
- Throughout the course, a theory-demonstrate-practice-activity strategy may be used to ensure that learning is outcome and employability based.
- All demonstrations/Hand-on practices may be followed in the real environment as far as possible.



1021236246	<b>Electrical Vehicle Technology Practical</b>	L	T	P	C
PRACTICUM		1	0	4	3

### Assessment Methodology

	Continuous Assessment (40 marks)				End Semester Examination (60 marks)
	CA1	CA2	CA3	CA4	
<b>Mode</b>	Practical Test	Practical Test	Written Test Theory	Practical Test	Practical Examination
<b>Portion</b>	Cycle I Exercises	Cycle II Exercises	All Portions	All Exercises	All Exercises Experiments
<b>Duration</b>	2 Periods	2 Periods	3 Hours	3 Hours	3 hours
<b>Exam Marks</b>	60	60	100	100	100
<b>Converted to Marks</b>	10	10	15	15	60
<b>Marks</b>	10		15	15	60
<b>Tentative Schedule</b>	7th Week	14th Week	15th Week	16th Week	

Note:

**CA1 and CA2:** All the exercises/experiments should be completed as per the portions above and kept for the practical test. The students shall be permitted to select any one by lot for the test. The practical test should be conducted as per the scheme of evaluation as below. The marks awarded shall be converted to 10 Marks for each assessment test. Best of one will be considered for the internal assessment of 10 Marks.

Practical documents should be maintained for every experiment immediately after completion of the practice. The practical document should be submitted for the practical test. The same should be evaluated for 10 Marks for each exercise/experiment. The total marks awarded should be converted to 10 Marks for the practical test as per the scheme of evaluation as below.



1021236246	<b>Electrical Vehicle Technology Practical</b>	L	T	P	C
PRACTICUM		1	0	4	3

**The details of the practical documents are to be prepared as per the instructions below.**

Each exercise / Experiment procedure, observation and calculations should be completed on the day of practice. The same shall be evaluated for 10 marks on the day or the next day of practice before the commencement of the next exercise.

This documentation can be carried out in a separate notebook or a printed manual or a file with documents. The Observation, reading, calculations, report, graphs and results should be written by the student manually in the practical documents.

The evaluated practical document should be submitted for the Practical Test. The marks scored by the students should be converted to 10 marks. The same should be included as per the allocation in the practical test.

The detailed dates of the practices and its evaluations should be maintained in the course logbook. The log book and the practical documents should be submitted for the verification by the Flying Squad and DOTE Official.

#### SCHEME OF EVALUATION

PART	DESCRIPTION	MARKS
A	Procedure / Explanation	10
B	Observation/ Assembly/ Reading	20
C	Report	20
TOTAL		50
D	Practical Documents (As per the portions)	10
		60

Cycle - I - Exercise 1, 2, 3,4 and 5.

Cycle - II - Exercise 6, 7, 8, 9 and 10.



1021236246	<b>Electrical Vehicle Technology Practical</b>	L	T	P	C
PRACTICUM		1	0	4	3

CA 3: Written Test for complete theory portions should be conducted for 100 Marks as per the question pattern below. The marks scored will be converted to 15 Marks for internal assessment.

**Question pattern – Written Test Theory**

Description		Marks	
Part – A	30 MCQ Questions.	30 X 1 Mark	30 Marks
Part – B	7 Questions to be answered out of 10 Questions.	7 X 10 Marks	70 Marks
TOTAL			100 Marks

**CA 4:** All the exercises/experiments should be completed and kept for the practical test. The students shall be permitted to select any one by lot for the test. The practical test should be conducted as per the scheme of evaluation below. After completion of all the exercises, the practical test should be conducted as per the End Semester Examination question pattern scheme of evaluation. The marks awarded should be converted to 15 Marks for the internal assessment.

**SCHEME OF EVALUATION**

Model Practical Examination and End Semester Examination - Practical Exam

PART	DESCRIPTION	MARKS
A	Procedure / Explanation	10
B	Observation/ Assembly/ Reading	20
C	Report	20
D	Result	10
E	Written Test (Theory Portion)	30
F	Viva Voce	10
TOTAL		100

Note: For the written test 30 MCQ shall be asked from the theory portions.



1021236246	<b>Electrical Vehicle Technology Practical</b>	L	T	P	C
PRACTICUM		1	0	4	3

### Syllabus Contents

<b>Theory Portion</b>	
Configuration of Electric Vehicle – Electric Traction – Battery Capacity, The Temperature Dependence of Battery Capacity, State of Charge of a VRLA Battery, Capacity Discharge Testing of VRLA Batteries, Battery Capacity Recovery, Definition of NiMH Battery Capacity, Li-ion Battery Capacity, Battery Capacity Tests, Energy Balances for the Electric Vehicle. Battery Management System: Functions of BMS - BMS building blocks- Mode of power - Design consideration of BMS - Battery cell balancing -Balancing methods – Active cell and Passive cell balancing. DC & AC Induction Motor Drives - Motor Controller - pulse width modulation techniques – Performance Characteristics Electric Vehicle Body and Frame - Electronic Power steering - Regenerative Braking, Battery Cycle Life - Battery cooling system – Basics of Arduino and Raspberry -Pi - IoT in EV.	15
<b>Practical Exercises</b>	
<b>Experiment 1:</b> Measure the capacity and efficiency of different types of batteries (Li-ion, NiMH, etc.).	5
<b>Experiment 2:</b> Design and simulate a simple BMS to monitor battery voltage, temperature, and current.	5
<b>Experiment 3:</b> Measure torque, speed, and efficiency of a DC motor.	5
<b>Experiment 4:</b> Control an AC motor using an inverter and study the impact of frequency and voltage on motor performance.	5
<b>Experiment 5:</b> Design and implement a simple BLDC motor controller.	
<b>Experiment 6:</b> Build and test a basic buck or boost converter.	5
<b>Experiment 7:</b> Design and simulate a basic regenerative braking system.	5
<b>Experiment 8:</b> Program a microcontroller to control motor speed and direction.	5



1021236246	<b>Electrical Vehicle Technology Practical</b>	L	T	P	C
PRACTICUM		1	0	4	3

<b>Experiment 9:</b> Develop a system to monitor EV parameters remotely using IoT devices.	5
<b>Experiment 10:</b> Conduct experiments with different cooling techniques for batteries and power electronics.	5
Test + Revision	10
Total	75

#### **Suggested List of Students Activity:**

Use simulation software to model and analyze EV systems.

Use software tools to simulate different driving cycles (urban, highway).

Learn and practice safety procedures for working with high-voltage systems in EVs.

#### **Text book for Reference:**

1. A.K Babu, Electric & Hybrid Vehicle, Second edition, Khanna Publication, 2022.
2. James D. Halderman, Electric and Hybrid Electric Vehicles, First edition Pearson, 2023.
3. Mehrdad Ehsani, Yimin Gao, Sebastien E.Gay, Ali Emadi, Modern Electric, Hybrid Electric and Fuel Cell Vehicles, Third edition, CRC Press, 2019.
4. Iqbal Husian, Electric and Hybrid Vehicle Design Fundamentals, Third edition, CRC Press, 2021.

#### **Web-based/Online Resources:**

- <https://nptel.ac.in/courses/108106170>
- <https://nptel.ac.in/courses/108103009>
- <https://in.mathworks.com/help/autoblks/powertrain-reference-applications.html>



1021236246	<b>Electrical Vehicle Technology Practical</b>	L	T	P	C
PRACTICUM		1	0	4	3

### Equipment / Facilities required

#### Experiment 1:

- Battery cells (Li-ion, NiMH)
- Battery tester/analyzer
- Multimeter
- Battery charger
- Temperature sensor

#### Experiment 2:

- Microcontroller (Arduino, Raspberry Pi)
- Voltage sensors
- Current sensors
- Temperature sensors
- Software for simulation (MATLAB/Simulink)

#### Experiment 3:

- DC motor
- Power supply
- Tachometer
- Dynamometer
- Multimeter

#### Experiment 4:

- AC motor
- Inverter
- Function generator
- Oscilloscope
- Power supply

#### Experiment 5:

- BLDC motor
- BLDC motor controller kit
- Microcontroller (Arduino, Raspberry Pi)
- Hall sensors
- Power supply

#### Experiment 6:

- DC-DC converter components (inductors, capacitors, diodes, transistors)
- Breadboard
- Multimeter
- Oscilloscope
- Power supply



1021236246	<b>Electrical Vehicle Technology Practical</b>	L	T	P	C
PRACTICUM		1	0	4	3

**Experiment 7:**

- Simulation software (MATLAB/Simulink)
- Motor-generator setup
- Power supply
- Braking resistor

**Experiment 8:**

- Microcontroller (Arduino, Raspberry Pi)
- Motor driver circuit
- DC motor or BLDC motor
- Power supply
- Sensors (for feedback control)

**Experiment 9:**

- Microcontroller with Wi-Fi (ESP8266, ESP32)
- Sensors (voltage, current, temperature)
- Power supply
- IoT platform (ThingSpeak, Blynk)

**Experiment 10:**

- Battery pack
- Cooling system components (fans, heat sinks, liquid cooling system)
- Temperature sensors
- Thermocouples
- Data logger



1021236246	<b>Electrical Vehicle Technology Practical</b>	L	T	P	C
PRACTICUM		1	0	4	3

### END SEMESTER EXAMINATIONS – PRACTICAL EXAM

**Note:**

All the exercises / experiments should be completed before the Board Practical Examinations. End Semester Practical examination should be conducted for all the exercises / experiments for 100 Marks. Students will be permitted to select any one exercise by lot or question paper supplied by the DOTE Exam section shall be used.

The Practical Documents by the student should be submitted with a Bonafide Certificate.

PART	DESCRIPTION	MARKS
A	Procedure / Explanation	10
B	Observation/ Assembly/ Reading	20
C	Report	20
D	Result	10
E	Written Test (Theory Portion)	30
F	Viva Voce	10
TOTAL		100

Note: For the written test 30 MCQ shall be asked from the theory portions.



1021236351	<b>Internship</b>	540 Periods	C
PROJECT			12

### **Introduction**

Internships in educational institutions are designed to provide students with practical experience in their field of study and to bridge the gap between academic knowledge and professional practice.

### **Objectives**

After completing Internship, Interns will be able to,

- Apply the theoretical knowledge and skill during performance of the tasks assigned in internship.
- Demonstrate soft skills such as time management, positive attitude and communication skills during performance of the tasks assigned in internship.
- Document the Use case on the assigned Task.
- Enable interns to apply theoretical knowledge gained in the classroom to real-world practical applications.
- Provide hands-on experience in the industrial practices.
- Develop essential skills such as communication, organization, teamwork, and problem-solving.
- Enhance specific skills related to the intern's area of focus.
- Offer a realistic understanding of the daily operations and responsibilities.
- Provide opportunities to work under the guidance of experienced supervisors and administrators.
- Allow interns to explore different career paths.
- Help interns make informed decisions about their future career goals based on first hand experience.
- Facilitate the establishment of professional relationships with supervisor, administrators, and other professionals in the field.



1021236351	<b>Internship</b>	540 Periods	C
PROJECT			12

- Provide access to a network of contacts that can be beneficial for future job opportunities and professional growth.
- Foster personal growth by challenging interns to step out of their comfort zones and take on new responsibilities.
- Build confidence and self-efficacy through successful completion of internship tasks and projects.
- Give insight into the policies, regulations, and administrative practices.
- Allow interns to observe and understand the implementation of standards and policies in practice.
- Provide opportunities for constructive feedback from supervisors and mentors, aiding in the intern's professional development.
- Enable self-assessment and reflection on strengths, areas for improvement, and career aspirations.
- Encourage sensitivity to the needs and backgrounds of different groups, promoting inclusive and equitable industrial practices.

### **Course Outcomes**

CO 1: Demonstrate improved skills.

CO 2: Exhibit increased professional behavior.

CO 3: Apply theoretical knowledge and principles in real-world practices.

CO 4: Develop and utilize assessment tools to evaluate the learning and practices.

CO 5: Engage in reflective practice to continually improve their learning and professional growth.

### **Facilitating the Interns by an Internship Provider.**

Orient intern in the new workplace. Give interns an overview of the organization, Explain the intern's duties and introduce him or her to co-workers.



1021236351	<b>Internship</b>	540 Periods	C
PROJECT			12

Develop an internship job description with clear deliverables and timeline.

Allow the interns in meetings and provide information, resources, and opportunities for professional development.

The interns have never done this kind of work before, they want to know that their work is measuring up to organizational expectations, hence provide professional guidance and mentoring to the intern.

Daily progress report of Intern is to be evaluated by industry supervisor. examine what the intern has produced and make suggestions. Weekly supervision meetings can help to monitor the intern's work.

#### **Duties Responsibilities of the Faculty Mentor**

To facilitate the placement of students for the internship

To liaison between the college and the internship provider

To assist the Industrial Training Supervisor during assessment

#### **Instructions to the Interns**

- Students shall report to the internship provider on the 1st day as per the internship schedule.
- Intern is expected to learn about the organization, its structure, product range, market performance, working philosophy etc.
- The interns shall work on live projects assigned by the internship provider.
- The Intern shall record all the activities in the daily log book and get the signature of the concerned training supervisor.
- Intern shall have 100% attendance during internship programme. In case of unavoidable circumstances students may avail leave with prior permission from the concerned training supervisor of the respective internship provider. However, the maximum leave permitted during internship shall be as per company norms where they are working and intern shall report the leave sanctioned details to their college faculty mentor.



1021236351	<b>Internship</b>	540 Periods	C
PROJECT			12

- The interns shall abide all the Rules and Regulations of internship provider
- Intern shall follow all the safety Regulations of internship provider.
- On completion of the internship, the intern shall report to the college and submit the internship certificate mentioning duration of internship, evaluation of interns by internship provider, Student's Diary and Comprehensive Training Report.

### **Attendance Certification**

Every month students have to get their attendance certified by the industrial supervisor in the prescribed form supplied to them. Students have also to put their signature on the form and submit it to the institution supervisor. Regularity in attendance and submission of report will be duly considered while awarding the Internal Assessment mark.

### **Training Reports**

The students have to prepare two types of reports: Weekly reports in the form of a diary to be submitted to the concerned staff in-charge of the institution. This will be reviewed while awarding Internal

### **Industrial Training Diary**

Students are required to maintain the record of day-to-day work done. Such a record is called Industrial training Diary. Students have to write this report regularly. All days for the week should be accounted for clearly giving attendance particulars (Presence, absence, Leave, Holidays etc.). The concern of the Industrial supervisor is to periodically check these progress reports.

### **Comprehensive Training Report**

In addition to the diary, students are required to submit a comprehensive report on training with details of the organisation where the training was undergone after attestation by the supervisors. The comprehensive report should incorporate study of plant/product/process/construction along with intensive in-depth study on any one of



1021236351	<b>Internship</b>	540 Periods	C
PROJECT			12

the topics such as processes, methods, tooling, construction and equipment, highlighting aspects of quality, productivity and system. The comprehensive report should be completed in the last week of Industrial training.

Any data, drawings etc. should be incorporated with the consent of the Organisation.

### **Scheme of Evaluation**

#### **Internal Assessment**

Students should be assessed for 50 Marks by industry supervisor and polytechnic faculty mentor during 8th Week and 15th Week. The total marks (50 + 50) scored shall be converted to 40 marks for the Internal Assessment.

Sl. No.	Description	Marks
A	Punctuality and regularity. (Attendance)	10
B	Level / proficiency of practical skills acquired. Initiative in learning / working at site	10
C	Ability to solve practical problems. Sense of responsibility	10
D	Self expression / communication skills. Interpersonal skills / Human Relation.	10
E	Report and Presentation.	10
Total		50



1021236351	<b>Internship</b>	540 Periods	C
PROJECT			12

### End Semester Examination - Project Exam

Students should be assessed for 100 Marks both by the internal examiner and external examiner appointed by the Chairman Board of Examinations after the completion of internship period (Dec - May). The marks scored will be converted to 60 marks for the End Semester Examination.

Sl. No.	Description	Marks
A	Daily Activity Report.	20
B	Comprehensive report on Internship, Relevant Internship Certificate from the concerned department.	30
C	Presentation by the student at the end of the Internship.	30
D	Viva Voce	20
Total		100



1021236353	<b>Fellowship</b>	540 Periods	C
PROJECT			12

### **Introduction**

The Fellowship in the Diploma in Engineering program is designed to provide aspiring engineers with a comprehensive educational experience that combines theoretical knowledge with practical skills. This fellowship aims to cultivate a new generation of proficient and innovative engineers who are equipped to meet the challenges of a rapidly evolving technological landscape.

Participants in this fellowship will benefit from a robust curriculum that covers core engineering principles, advanced technical training, and hands-on projects. The program emphasizes interdisciplinary learning, encouraging fellows to explore various branches of engineering, from mechanical and civil to electrical, electronics & communication and computer engineering. This approach ensures that graduates possess a versatile skill set, ready to adapt to diverse career opportunities in the engineering sector.

In addition to academics, the fellowship offers numerous opportunities for professional development. Fellows will engage with industry experts through seminars, workshops, and internships, gaining valuable insights into real-world applications of their studies. Collaborative projects and research initiatives foster a culture of innovation, critical thinking, and problem-solving, essential attributes for any successful engineer.

By offering this fellowship, participants become part of a vibrant community of learners and professionals dedicated to advancing the field of engineering. The program is committed to supporting the growth and development of each fellow, providing them with the tools and resources needed to excel both academically and professionally.

The Fellowship in the Diploma in Engineering is more than just an educational endeavor; it is a transformative journey that equips aspiring engineers with the knowledge, skills, and experiences necessary to make significant contributions to society and the engineering profession.



1021236353	<b>Fellowship</b>	540 Periods	C
PROJECT			12

### Objectives

After completing students will be able to,

- Provide fellows with a solid foundation in core engineering principles and advanced technical knowledge across various engineering disciplines.
- Equip fellows with hands-on experience through laboratory work, projects, and internships, ensuring they can apply theoretical knowledge to real-world scenarios.
- Promote interdisciplinary understanding by encouraging exploration and integration of different engineering fields, fostering versatility and adaptability in fellows.
- Encourage innovation and creativity through research projects and collaborative initiatives, enabling fellows to develop new solutions to engineering challenges.
- Facilitate professional growth through workshops, seminars, and interactions with industry experts, preparing fellows for successful careers in engineering.
- Develop critical thinking and problem-solving skills, essential for tackling complex engineering problems and making informed decisions.
- Strengthen connections between academia and industry by providing opportunities for internships, industry visits, and guest lectures from professionals.
- Foster leadership qualities and teamwork skills through group projects and collaborative activities, preparing fellows for leadership roles in their future careers.
- Instill a sense of ethical responsibility and awareness of the social impact of engineering practices, encouraging fellows to contribute positively to society.
- Promote a culture of lifelong learning, encouraging fellows to continually update their knowledge and skills in response to technological advancements and industry trends.
- Prepare fellows to work in a global engineering environment by exposing them to international best practices, standards, and cross-cultural experiences.



1021236353	<b>Fellowship</b>	540 Periods	C
PROJECT			12

### Course Outcomes

**CO 1:** Demonstrate a strong understanding of core engineering principles and possess the technical skills necessary to design, analyze, and implement engineering solutions across various disciplines.

**CO 2:** Apply theoretical knowledge to practical scenarios, effectively solving engineering problems through hands-on projects, laboratory work, and internships.

**CO 3:** Exhibit the ability to conduct research, develop innovative solutions, and contribute to advancements in engineering through critical thinking and creative approaches to complex challenges.

**CO 4:** Understand and adhere to professional and ethical standards in engineering practice, demonstrating responsibility, integrity, and a commitment to sustainable and socially responsible engineering.

**CO 5:** Enhance strong communication skills, both written and verbal, and be capable of working effectively in teams, demonstrating leadership and collaborative abilities in diverse and multidisciplinary environments.

### Important points to consider to select the fellowship project.

Selecting the right fellowship project is crucial for maximizing the educational and professional benefits of a Diploma in Engineering program.

- **Relevance to Future Plans:** Choose a project that aligns with your long-term career aspirations and interests. This alignment will ensure that the skills and knowledge you gain will be directly applicable to your desired career path.
- **Industry Relevance:** Consider the current and future relevance of the project within the industry. Opt for projects that address contemporary challenges or emerging trends in engineering.
- **Access to Facilities:** Ensure that the necessary facilities, equipment, and materials are available to successfully complete the project. Lack of resources can hinder the progress and quality of your work.



1021236353	<b>Fellowship</b>	540 Periods	C
PROJECT			12

- **Mentorship and Guidance:** Select a project that offers strong mentorship and support from experienced faculty members or industry professionals. Effective guidance is crucial for navigating complex problems and achieving project objectives.
- **Project Scope:** Assess the scope of the project to ensure it is neither too broad nor too narrow. A well-defined project scope helps in setting clear objectives and achievable milestones.
- **Feasibility:** Evaluate the feasibility of completing the project within the given timeframe and with the available resources. Consider potential challenges and ensure you have a realistic plan to address them.
- **Technical Skills:** Choose a project that allows you to develop and enhance important technical skills relevant to your field of study. Practical experience in using specific tools, technologies, or methodologies can be highly beneficial.
- **Soft Skills:** Consider projects that also offer opportunities to develop soft skills such as teamwork, communication, problem-solving, and project management.
- **Innovative Thinking:** Select a project that encourages creativity and innovative problem-solving. Projects that push the boundaries of traditional engineering approaches can be particularly rewarding.
- **Societal Impact:** Consider the potential impact of your project on society or the engineering community. Projects that address significant challenges or contribute to social good can be highly fulfilling and make a meaningful difference.

#### **Guidelines to select Fellowship**

- Ensure the program is accredited by a recognized accrediting body and has a strong reputation for quality education in engineering.
- Ensure it covers core engineering principles that align with your interests and career goals.
- Investigate the qualifications and experience of the faculty mentor. Look for programs with faculty who have strong academic backgrounds, industry experience, and active involvement in research.



1021236353	<b>Fellowship</b>	540 Periods	C
PROJECT			12

- Check if the program provides adequate hands-on training opportunities, such as laboratory work, workshops, and access to modern engineering facilities and equipment.
- Assess the program's connections with industry. Strong partnerships with companies can lead to valuable internship opportunities, industry projects, and exposure to real-world engineering challenges.
- Explore the availability of research opportunities. Participation in research projects can enhance your learning experience and open doors to innovative career paths.
- Look for programs that offer professional development resources, such as workshops, seminars, and networking events with industry professionals and alumni.
- Ensure the program provides robust support services, including academic advising, career counseling, mentorship programs, and assistance with job placement after graduation.
- Consider the cost of the program and available financial aid options, such as scholarships, grants, and fellowships. Evaluate the return on investment in terms of career prospects and potential earnings.
- Research the success of the program's alumni. High employment rates and successful careers of past graduates can indicate the program's effectiveness in preparing students for the engineering field.

### **Duties Responsibilities of the Faculty Mentor**

Each student should have a faculty mentor for the Institute.

- Get the approval from the Chairman Board of Examinations with the recommendations of the HOD/Principal for the topics.
- Provide comprehensive academic advising to help fellows select appropriate specializations, and research projects that align with their interests and career goals.
- Guide fellows through their research projects, offering expertise and feedback to ensure rigorous methodology, innovative approaches, and meaningful contributions to the field.
- Assist fellows in developing technical and professional skills through hands-on projects, laboratory work, and practical applications of theoretical knowledge.



1021236353	<b>Fellowship</b>	540 Periods	C
PROJECT			12

- Offer career advice and support, helping fellows explore potential career paths, prepare for job searches, and connect with industry professionals and opportunities.
- Provide personal mentorship, fostering a supportive relationship that encourages growth, resilience, and a positive academic experience.
- Facilitate connections between fellows and industry professionals, alumni, and other relevant networks to enhance their professional opportunities and industry exposure.
- Ensure fellows have access to necessary resources, including research materials, lab equipment, software, and academic literature.
- Regularly monitor and evaluate the progress of fellows, providing constructive feedback and guidance to help them stay on track and achieve their goals.
- Instill and uphold high ethical and professional standards, encouraging fellows to practice integrity and responsibility in their work.
- Assist with administrative tasks related to the fellowship program, such as preparing progress reports, writing recommendation letters, and facilitating grant applications.
- Organize and participate in workshops, seminars, and other educational events that enhance the learning experience and professional development of fellows.
- Address any issues or conflicts that arise, providing mediation and support to ensure a positive and productive academic environment.

#### **Instructions to the Fellowship Scholar**

- Regularly meet with your faculty mentor for guidance on academic progress, research projects, and career planning. Be proactive in seeking advice and support from your mentor.
- Develop strong organizational skills. Use planners, calendars, and task management tools to keep track of assignments, project deadlines, and study schedules. Prioritize tasks to manage your time efficiently.
- Take advantage of opportunities to participate in research projects and hands-on activities. These experiences are crucial for applying your theoretical knowledge and gaining practical skills.



1021236353	<b>Fellowship</b>	540 Periods	C
PROJECT			12

- Focus on improving essential professional skills such as communication, teamwork, problem-solving, and leadership. Participate in workshops and seminars that enhance these competencies.
- Actively seek networking opportunities through industry events, seminars, and meetings. Establish connections with peers, alumni, and professionals in your field to build a strong professional network.
- Seek internships, co-op programs, or part-time jobs related to your field of study. Real-world experience is invaluable for understanding industry practices and enhancing your employability.
- Uphold high ethical standards in all your academic and professional activities. Practice integrity, honesty, and responsibility. Adhere to the ethical guidelines and standards set by your institution and the engineering profession.
- Adopt a mindset of lifelong learning. Stay updated with the latest developments and trends in engineering by reading industry journals, attending conferences, and taking additional courses.

**Documents to be submitted by the student to offer fellowship.**

- **Completed Application Form:** This is typically the standard form provided by the institution or fellowship program that includes personal information, educational background, and other relevant details.
- **Detailed CV/Resume:** A comprehensive document outlining your educational background, knowledge experience, interest in research experience, publications, presentations, awards, and other relevant achievements if any.
- **Personal Statement:** A document explaining your motivation for applying to the fellowship, your career goals, how the fellowship aligns with those goals, and what you intend to achieve through the program.
- **Recommendation Letters:** Letters from faculty mentor, employer, or professionals who can attest to your academic abilities, professional skills, and suitability for the fellowship.



1021236353	<b>Fellowship</b>	540 Periods	C
PROJECT			12

- **Proposal/Description:** A detailed proposal or description of the fellowship project or study you plan to undertake during the fellowship. This should include objectives, methodology, expected outcomes, and significance of the project.
- **Enrollment Verification:** Documentation verifying your current acceptance status in the academic institution or industry where the fellowship will be conducted.
- **Funding Information:** Details about any other sources of funding or financial aid you are receiving, if applicable. Some fellowships may also require a budget proposal for the intended use of the fellowship funds.
- **Samples of Work:** Copies of the relevant work that demonstrates your capabilities and accomplishments in your field.
- **Endorsement Letter:** A letter from your current academic institution endorsing your application for the fellowship, if required.
- **Ethical Approval Documents:** If your research involves human subjects or animals, you may need to submit proof of ethical approval from the relevant ethics committee.
- **Additional Documents:** Any other documents requested by the fellowship program required by the institution.

### **Attendance Certification**

Every month students have to get their attendance certified by the supervisor in the prescribed form supplied to them. Students have also to put their signature on the form and submit it to the faculty mentor. Regularity in attendance and submission of report will be duly considered while awarding the Internal Assessment mark.



1021236353	<b>Fellowship</b>	540 Periods	C
PROJECT			12

**Rubrics for Fellowship. Review I & II.**

Sl. No.	Topics	Description
1	Alignment with Objectives	Assess how well the project aligns with the stated objectives and requirements.  Determine if the student has addressed the key aspects outlined in the project guidelines.
2	Depth of Research:	Evaluate the depth and thoroughness of the literature review.  Assess the student's ability to identify and address gaps in existing research.
3	Clarity of Objectives:	Check if the student has clearly defined and articulated the objectives of the project.  Ensure that the objectives are specific, measurable, achievable, relevant, and time-bound (SMART).
4	Methodology and Data Collection:	Evaluate the appropriateness and justification of the research methodology.  Assess the methods used for data collection and their relevance to the research questions.
5	Analysis and Interpretation:	Examine the quality of data analysis techniques used.  Assess the student's ability to interpret results and draw meaningful conclusions.
6	Project Management:	Evaluate the project management aspects, including adherence to timelines and milestones.  Assess the student's ability to plan and execute the project effectively.



1021236353	<b>Fellowship</b>	540 Periods	C
PROJECT			12

7	Documentation and Reporting:	<p>Check the quality of documentation, including code, experimental details, and any other relevant materials.</p> <p>Evaluate the clarity, structure, and coherence of the final report.</p>
8	Originality and Creativity:	<p>Assess the level of originality and creativity demonstrated in the project.</p> <p>Determine if the student has brought a unique perspective or solution to the research problem.</p>
9	Critical Thinking:	<p>Evaluate the student's critical thinking skills in analyzing information and forming conclusions.</p> <p>Assess the ability to evaluate alternative solutions and make informed decisions.</p>
10	Problem-Solving Skills:	<p>Evaluate the student's ability to identify and solve problems encountered during the project.</p> <p>Assess adaptability and resilience in the face of challenges.</p>



1021236353	<b>Fellowship</b>	540 Periods	C
PROJECT			12

**INTERNAL MARKS - 40 Marks**

As per the rubrics each topic should be considered for the Review I and Review II. Equal weightage should be given for all the topics. It should be assessed by a faculty mentor and the industrial professional or research guide.

Review 1 shall be conducted after 8th week and Review 2 shall be conducted after 14th week in the semester. Average marks scored in the reviews shall be considered for the internal assessment of 30 Marks.

**Scheme of Evaluation**

PART	DESCRIPTION	MARKS
<b>A</b>	Assessment as per the rubrics.	30
<b>B</b>	Attendance	10
<b>Total</b>		<b>40</b>



1021236353	<b>Fellowship</b>	540 Periods	C
PROJECT			12

**END SEMESTER EXAMINATION - Project Exam**

Students should be assessed for 100 Marks both by the internal examiner and external examiner appointed by the Chairman Board of Examinations after the completion of fellowship. The marks scored will be converted to 60 marks for the End Semester Examination.

Sl. No.	Description	Marks
A	Daily Activity Report.	20
B	Comprehensive report of the Fellowship Work.	30
C	Presentation by the student.	30
D	Viva Voce	20
Total		100



1021236374	<b>In-house Project</b>	540 Periods	C
PROJECT			12

### Introduction

Every student must do one major project in the Final year of their program. Students can do their major project in Industry or R&D Lab or in-house or a combination of any two for the partial fulfillment for the award of Diploma in Engineering.

For the project works, the Department will constitute a three-member faculty committee to monitor the progress of the project and conduct reviews regularly.

If the projects are done in-house, the students must obtain the bonafide certificate for project work from the Project supervisor and Head of the Department, at the end of the semester. Students who have not obtained the bonafide certificate are not permitted to appear for the Project Viva Voce examination.

For the projects carried out in Industry, the students must submit a separate certificate from Industry apart from the regular bonafide certificate mentioned above. For Industry related projects there must be one internal faculty advisor / Supervisor from Industry (External), this is in addition to the regular faculty supervision.

The final examination for project work will be evaluated based on the final report submitted by the project group **of not exceeding four students**, and the viva voce by an external examiner.

### Objectives

Academic project work plays a crucial role in the education of Diploma in Engineering students, as it helps them apply theoretical knowledge to practical situations and prepares them for real-world engineering challenges.

- **Integration of Knowledge:** Consolidate and integrate theoretical knowledge acquired in coursework to solve practical engineering problems.
- **Skill Development:** Enhance technical skills related to the specific field of engineering through hands-on experience and application.
- **Problem-Solving Abilities:** Develop critical thinking and problem-solving abilities by addressing complex engineering issues within a defined scope.
- **Project Management:** Gain experience in project planning, execution, and management, including setting objectives, timelines, and resource allocation.



1021236374	<b>In-house Project</b>	540 Periods	C
PROJECT			12

- **Teamwork and Collaboration:** Foster teamwork and collaboration by working in multidisciplinary teams to achieve project goals and objectives.
- **Research Skills:** Acquire research skills by conducting literature reviews, gathering relevant data, and applying research methodologies to investigate engineering problems.
- **Innovation and Creativity:** Encourage innovation and creativity in proposing and developing engineering solutions that may be novel or improve upon existing methods.
- **Communication Skills:** Improve communication skills, both oral and written, by presenting project findings, writing technical reports, and effectively conveying ideas to stakeholders.
- **Ethical Considerations:** Consider ethical implications related to engineering practices, including safety, environmental impact, and societal concerns.
- **Professional Development:** Prepare for future professional roles by demonstrating professionalism, initiative, and responsibility throughout the project lifecycle.

### Course Outcomes

**CO 1:** Demonstrate the ability to apply theoretical concepts and principles learned in coursework to solve practical engineering problems encountered during the project.

**CO 2:** Develop and enhance technical skills specific to the field of engineering relevant to the project, such as design, analysis, simulation, construction, testing, and implementation.

**CO 3:** Apply critical thinking and problem-solving skills to identify, analyze, and propose solutions to engineering challenges encountered throughout the project lifecycle.

**CO 4:** Acquire project management skills by effectively planning, organizing, and executing project tasks within defined timelines and resource constraints.

**CO 5:** Improve communication skills through the preparation and delivery of project reports, presentations, and documentation that effectively convey technical information to stakeholders.

**Important points to consider to select the In-house project.**



1021236374	<b>In-house Project</b>	540 Periods	C
PROJECT			12

- Selecting a project work in Diploma Engineering is a significant decision that can greatly influence your learning experience and future career prospects.
- Choose a project that aligns with your career aspirations and interests within the field of engineering. Consider how the project can contribute to your professional development and future opportunities.
- Ensure the project aligns with your coursework and specialization within the Diploma program. It should complement and build upon the knowledge and skills you have acquired in your studies.
- Evaluate the scope of the project to ensure it is manageable within the given timeframe, resources, and constraints. Avoid projects that are overly ambitious or impractical to complete effectively.
- Assess the availability of resources needed to conduct the project, such as equipment, materials, laboratory facilities, and access to relevant software or tools. Lack of resources can hinder project progress.
- Select a project that genuinely interests and motivates you. A project that captures your curiosity and passion will keep you engaged and committed throughout the project duration.
- Consider the availability and expertise of faculty advisors or industry mentors who can provide guidance and support throughout the project. Effective mentorship is crucial for success.
- Clearly define the learning objectives and expected outcomes of the project. Ensure that the project will help you achieve specific learning goals related to technical skills, problem-solving, and professional development.
- Look for opportunities to propose innovative solutions or explore new methodologies within your project. Projects that encourage creativity can set you apart and enhance your learning experience.
- Consider ethical implications related to the project, such as safety protocols, environmental impact, and compliance with ethical guidelines in research and engineering practices.



1021236374	<b>In-house Project</b>	540 Periods	C
PROJECT			12

- Evaluate whether the project offers opportunities for collaboration with peers, experts from other disciplines, or industry partners. Interdisciplinary projects can broaden your perspective and enhance your teamwork skills.
- Consider the potential impact of your project on society or the engineering community. Projects that address significant challenges or contribute to social good can be highly fulfilling and make a meaningful difference.

By carefully considering these points, Diploma Engineering students can make informed decisions when selecting project work that not only enhances their academic learning but also prepares them for successful careers in engineering.

#### **Duties Responsibilities of the internal faculty advisor.**

Each group should have an internal faculty advisor assigned by the HOD/Principal.

- The in-house project should be approved by the project monitoring committee constituted by the Chairman Board of Examinations.
- The in-house project should be selected in the fifth semester itself. Each in-house project shall have a maximum of four students in the project group.
- Provide comprehensive academic advising to help in the selection of appropriate in-house project that align with their interests and career goals.
- Offer expertise and feedback to ensure rigorous methodology, innovative approaches, and meaningful contributions to the field.
- Assist in developing technical and professional skills through hands-on projects, laboratory work, and practical applications of theoretical knowledge.
- Provide personal mentorship, fostering a supportive relationship that encourages growth, resilience, and a positive academic experience.
- Facilitate connections between students and industry professionals, alumni, and other relevant networks to enhance their professional opportunities and industry exposure.
- Ensure students have access to necessary resources, including research materials, lab equipment, software, and academic literature.



1021236374	<b>In-house Project</b>	540 Periods	C
PROJECT			12

- Regularly monitor and evaluate the progress of the in-house project, providing constructive feedback and guidance to help them stay on track and achieve their goals.
- Instill and uphold high ethical and professional standards, encouraging students to practice integrity and responsibility in their work.
- Assist in preparing progress reports, writing recommendation letters, and facilitating grant applications.
- Organize and participate in workshops, seminars, and other educational events that enhance the learning experience and professional development .
- Address any issues or conflicts that arise, providing mediation and support to ensure a positive and productive academic environment.

#### **Instructions to the students.**

- Regularly meet with your internal faculty advisor for guidance on academic progress, research projects, and career planning. Be proactive in seeking advice and support from your faculty advisor.
- Use planners, calendars, and task management tools to keep track of assignments, project deadlines, and study schedules. Prioritize tasks to manage your time efficiently.
- Take advantage of opportunities to participate in in-house projects and hands-on activities. These experiences are crucial for applying your theoretical knowledge and gaining practical skills.
- Focus on improving essential professional skills such as communication, teamwork, problem-solving, and leadership. Participate in workshops and seminars that enhance these competencies.
- Actively seek networking opportunities through industry events, seminars, and meetings. Establish connections with peers, alumni, and professionals in your field to build a strong professional network.
- Seek internships, co-op programs, or part-time jobs related to your field of study. Real-world experience is invaluable for understanding industry practices and enhancing your employability.



1021236374	<b>In-house Project</b>	540 Periods	C
PROJECT			12

- Uphold high ethical standards in all your academic and professional activities. Practice integrity, honesty, and responsibility. Adhere to the ethical guidelines and standards set by your institution and the engineering profession.
- Adopt a mindset of lifelong learning. Stay updated with the latest developments and trends in engineering by reading industry journals, attending conferences, and taking additional courses.

**Documents to be submitted by the student for an in-house project.**

Submit a printed report of your in-house project work along with the fabrication model / analysis report for the End Semester Examination.

**Rubrics for In-House Project Work**

Sl. No.	Topics	Description
1	Objectives	Clearly defined and specific objectives outlined. Objectives align with the project's scope and purpose.
2	Literature Review	Thorough review of relevant literature. Identification of gaps and justification for the project's contribution.
3	Research Design and Methodology	Clear explanation of the research design. Appropriateness and justification of chosen research methods.
4	Project Management	Adherence to project timeline and milestones. Effective organization and planning evident in the project execution.



1021236374	<b>In-house Project</b>	540 Periods	C
PROJECT			12

5	Documentation	Comprehensive documentation of project details. Clarity and completeness in recording methods, results, and challenges.
6	Presentation Skills	Clear and articulate communication of project findings. Effective use of visuals, if applicable.
7	Analysis and Interpretation	In-depth analysis of data. Clear interpretation of results in the context of research questions.
8	Problem-Solving	Demonstrated ability to identify and address challenges encountered during the project. Innovative solutions considered where applicable.
9	Professionalism and Compliance	Adherence to ethical standards in research. Compliance with project guidelines and requirements.
10	Quality of Work	Overall quality and contribution of the project to the field. Demonstrated effort to produce high-quality work.

### SCHEME OF EVALUATION

The mark allocation for Internal and End Semester Viva Voce are as below.



**DIRECTORATE OF TECHNICAL EDUCATION, CHENNAI – 600 025**  
**REGULATION 2023**

1021236374	<b>In-house Project</b>	540 Periods	C
PROJECT			12

<b>Internal Marks (40 Marks)*</b>		
Review 1 (10 Marks)	Review 2 (15 Marks)	Review 3 (15 marks)
Committee: 5 Marks. Supervisor: 5 Marks	Committee: 7.5 Marks Supervisor: 7.5 Marks	Committee: 7.5 Marks Supervisor: 7.5 Marks

Note: \* The rubrics should be followed for the evaluation of the internal marks during reviews.

### **END SEMESTER EXAMINATION - Project Exam**

The performance of each student in the project group would be evaluated in a viva voce examination conducted by a committee consisting of an external examiner and the project supervisor and an internal examiner.

<b>End Semester (100)#</b>			
Record (20 Marks)	Presentation (20 Marks)	Viva Voce (20 Marks)	Model / Analysis Report (40 Marks)
External: 10 Internal: 5 Supervisor: 5	External: 10 Internal: 5 Supervisor: 5	External: 10 Internal: 5 Supervisor: 5	External: 20 Internal: 10 Supervisor: 10

# The marks scored will be converted to 60 Marks.



2023234274 2023237274	<b>Industrial Training (SW)</b>	540 Periods	C
PROJECT			12

### Introduction

The main objective of the sandwich Diploma course is to mould a well-rounded technician acclimated with the industrial environment while being a student in the institution. The Sandwich Diploma Course study is pursued by students, in 7 Semesters of 3 ½ years duration, the subjects of 3 years-Full Time Diploma Course being regrouped for academic convenience.

While in the 4th semester students undergo Industrial Training for 6 months (December through May). They also do course work in the institution for one day in a week, While in the 7th semester they undergo another spell of 6 months (June through November) Industrial training.

The Apprenticeship (Amendment) Act 1973 is followed in regulating the Industrial training procedure for Sandwich Course.

### Objectives

The main objective of industrial training for a diploma engineer is to provide practical, hands-on experience in real-world industrial settings, bridging the gap between academic learning and professional practice. This training aims to equip students with the skills, knowledge, and competencies required to effectively perform and succeed in the mechanical engineering industry.

Key aspects of this objective include:

- Enable students to apply the concepts and principles learned in the classroom to real-world engineering problems and scenarios.
- Develop essential technical skills.
- Enhance soft skills like communication, teamwork, problem-solving, and time management.
- Provide exposure to industrial machinery, tools, and equipment, along with the operational procedures and safety practices in a manufacturing or engineering environment.
- Offer insights into the daily operations and responsibilities of technicians, preparing students for the transition from academic settings to professional work environments.



2023234274 2023237274	<b>Industrial Training (SW)</b>	540 Periods	C
PROJECT			12

- Educate students on industry standards, quality control measures, and best practices in mechanical engineering and manufacturing processes.
- Help students explore various career paths within mechanical engineering, enabling them to make informed decisions about their future professional goals.
- Provide opportunities for networking with industry professionals and potential employers.
- Encourage creative thinking and innovation by challenging students to solve real-world engineering problems and improve existing processes or products.
- Instill a sense of professionalism, work ethics, and responsibility required in the engineering field.

### **Course Outcomes**

CO 1: Demonstrate proficiency in using industrial machinery, tools, and software.

CO 2: Able to identify, analyze, and solve engineering problems using industry-standard methods and practices.

CO 3: Gain a comprehensive understanding of industrial manufacturing processes, quality control, and safety practices.

CO 4: Exhibit improved communication, teamwork, and professional behavior in an industrial setting.

CO 5: Apply theoretical concepts learned in their coursework to practical engineering tasks and projects.

### **Duties Responsibilities of the Faculty Mentor.**

Faculty mentors play a crucial role in overseeing and guiding students during their industrial training program in Diploma engineering.



2023234274 2023237274	<b>Industrial Training (SW)</b>	540 Periods	C
PROJECT			12

**Pre-Training Responsibilities:**

1. Orientation and Preparation:
  - Conduct orientation sessions to familiarize students with the objectives, expectations, and guidelines of the industrial training program.
  - Assist students in understanding the importance of industrial training in their academic and professional development.
2. Placement Coordination:
  - Collaborate with the placement cell or industry liaison office to secure suitable training placements for students that align with their academic specialization and career interests.
  - Facilitate communication between the institution and host organizations to ensure smooth coordination of training arrangements.
3. Training Plan Development:
  - Help students develop a detailed training plan outlining learning objectives, tasks, and expected outcomes for the training period.
  - Guide students in setting SMART (Specific, Measurable, Achievable, Relevant, Time-bound) goals for their training experience.

**During Training Responsibilities:**

4. Monitoring and Support:
  - Regularly monitor the progress of students during their industrial training. Maintain communication with both students and industry supervisors to track performance and address any issues that may arise.
  - Provide ongoing support and guidance to students, offering advice on technical challenges, professional conduct, and workplace etiquette.
5. Technical Guidance:
  - Offer technical guidance and mentorship related to the specific engineering discipline or specialization of the students. Help them apply theoretical knowledge to practical situations encountered in the industry.



2023234274 2023237274	<b>Industrial Training (SW)</b>	540 Periods	C
PROJECT			12

6. Problem-Solving Assistance:

- Assist students in overcoming obstacles or challenges encountered during their training. Encourage them to develop problem-solving skills and resilience in real-world engineering scenarios.

7. Feedback and Evaluation:

- Provide constructive feedback on students' performance based on reports, assessments, and observations gathered from industry supervisors.
- Evaluate students' achievements in relation to their training objectives and competencies developed during the program.

**Post-Training Responsibilities:**

8. Reflection and Debriefing:

- Conduct debriefing sessions with students to reflect on their training experiences, discuss lessons learned, and identify areas for further improvement.
- Help students articulate their learning outcomes and how these experiences contribute to their professional growth.

9. Documentation and Reporting:

- Ensure comprehensive documentation of students' training activities, achievements, and feedback received from industry supervisors.
- Prepare reports summarizing students' performance and submit these to relevant departments or committees for review and assessment.

10. Career Counseling:

- Provide career guidance and counseling to students based on their industrial training experiences. Assist them in leveraging these experiences for future job applications or further academic pursuits.

11. Continuous Improvement:

- Collaborate with industry partners to continuously improve the quality and relevance of the industrial training program.



2023234274 2023237274	<b>Industrial Training (SW)</b>	540 Periods	C
PROJECT			12

- Incorporate feedback from students and industry supervisors to enhance the effectiveness of future training placements.

By fulfilling these duties and responsibilities, faculty mentors contribute significantly to the overall educational experience and professional development of Diploma engineering students during their industrial training program.

### **Instructions to the students**

Here are some instructions for Diploma engineering students undergoing industrial training during their academic duration:

#### **Before Starting Industrial Training:**

##### **1. Orientation and Preparation:**

- Attend orientation sessions conducted by the institution or faculty mentors to understand the objectives, expectations, and guidelines of the industrial training program.
- Familiarize yourself with the specific policies, procedures, and safety regulations of the host organization where you will be undergoing training.

##### **2. Setting Goals:**

- Set clear and specific goals for your industrial training period. Define what skills, knowledge, and experiences you aim to gain during this time.
- Discuss your goals with your faculty mentor and seek their guidance in developing a training plan that aligns with your career aspirations.

##### **3. Professional Attire and Conduct:**

- Dress appropriately and professionally according to the standards of the industry and host organization.
- Maintain a positive attitude, demonstrate punctuality, and adhere to workplace etiquette and norms.



2023234274 2023237274	<b>Industrial Training (SW)</b>	540 Periods	C
PROJECT			12

**During Industrial Training:**

4. Learning and Engagement:

- Actively engage in all assigned tasks and projects. Seek opportunities to learn new skills and technologies relevant to your field of study.
- Take initiative in asking questions, seeking clarification, and participating in discussions with supervisors and colleagues.

5. Adaptability and Flexibility:

- Adapt to the work environment and demonstrate flexibility in handling various responsibilities and challenges that arise during your training.
- Be open to different roles and tasks assigned to you, as this will broaden your experience and skill set.

6. Professionalism and Communication:

- Communicate effectively with supervisors, colleagues, and clients as required. Practice clear and concise verbal and written communication.
- Demonstrate professionalism in all interactions, respecting confidentiality, and adhering to company policies and procedures.

7. Safety and Compliance:

- Prioritize safety at all times. Familiarize yourself with safety protocols, procedures, and emergency exits in the workplace.
- Follow all safety guidelines and regulations to ensure your well-being and that of others around you.

**After Completing Industrial Training:**

8. Reflection and Documentation:

- Reflect on your training experience. Evaluate what you have learned, the challenges you faced, and how you have grown professionally.
- Maintain a journal or log documenting your daily activities, achievements, and lessons learned during the training period.



2023234274 2023237274	<b>Industrial Training (SW)</b>	540 Periods	C
PROJECT			12

9. Feedback and Evaluation:

- Seek feedback from your industry supervisor and faculty mentor on your performance and areas for improvement.
- Use constructive feedback to enhance your skills and competencies for future career opportunities.

10. Career Planning:

- Use your industrial training experience to inform your career planning and decision-making process.
- Discuss your career goals and aspirations with your faculty mentor or career counselor for guidance on next steps after completing your diploma.

By following these instructions, Diploma engineering students can make the most of their industrial training experience, gain valuable insights into their chosen field, and prepare themselves effectively for future professional endeavors.

### **Attendance Certification**

Every month students have to get their attendance certified by the industrial supervisor in the prescribed form supplied to them. Students have also to put their signature on the form and submit it to the institution supervisor. Regularity in attendance and submission of report will be duly considered while awarding the Internal Assessment mark.

### **Training Reports**

The students have to prepare two types of reports: Weekly reports in the form of a diary to be submitted to the concerned faculty mentor of the institution. This will be reviewed while awarding Internal assessment. The details of the activity during the training will be monitored by the Faculty mentor through the faculty advisor and student.

The feedback shall be given to the HOD / Principal for further necessary action.



2023234274 2023237274	<b>Industrial Training (SW)</b>	540 Periods	C
PROJECT			12

### **Industrial Training Diary**

Students are required to maintain the record of day-to-day work done. Such a record is called Industrial training Diary. Students have to write this report regularly. All days for the week should be accounted for clearly giving attendance particulars (Presence, absence, Leave, Holidays etc.). The concern of the Industrial supervisor is to periodically check these progress reports.

### **Comprehensive Training Report**

In addition to the diary, students are required to submit a comprehensive report on training with details of the organisation where the training was undergone after attestation by the supervisors. The comprehensive report should incorporate study of plant / product / process / construction along with intensive in-depth study on any one of the topics such as processes, methods, tooling, construction and equipment, highlighting aspects of quality, productivity and system. The comprehensive report should be completed in the last week of Industrial training. Any data, drawings etc. should be incorporated with the consent of the Organisation.



2023234274 2023237274	<b>Industrial Training (SW)</b>	540 Periods	C
PROJECT			12

### Scheme of Evaluation

#### Internal Assessment

Students should be assessed for 40 Marks by industry supervisor and polytechnic faculty mentor during 3rd Month and 5th Month. The total marks (40 + 40) scored shall be converted to 40 marks for the Internal Assessment.

Sl. No.	Description	Marks
A	Punctuality and regularity. (Attendance)	10
B	Level / proficiency of practical skills acquired. Initiative in learning / working at site	10
C	Self expression / communication skills. Interpersonal skills / Human Relation.	10
D	Report and Presentation.	10
Total		40



2023234274 2023237274	<b>Industrial Training (SW)</b>	540 Periods	C
PROJECT			12

### End Semester Examination - Project Exam

Students should be assessed for 100 Marks both by the internal examiner and external examiner appointed by the Chairman Board of Examinations after the completion of internship period of six months. The marks scored will be converted to 60 marks for the End Semester Examination.

Sl. No.	Description	Marks
A	Daily Activity Report.	20
B	Comprehensive report on Internship, Relevant Internship Certificate from the concerned department.	30
C	Presentation by the student at the end of the Internship.	30
D	Viva Voce	20
Total		100

